

SCACR

Cylindrical Turning

End Face Turning

(Inserts): A15-A16 (Toolholder Parts): P01-P04



Ordering code	Dimensions						Insert	Wrench	Screw	Stock		Order Number
	h	b	L	L1	h1	f				R	L	
SCACR/L 0808K06	8	8	125	10	8	8	CC..0606..	T8	M2.5×7	●	●	216300
1010K06	10	10	125	10	10	10				●	●	216302
1212K09	12	12	125	13	12	12				●	●	216304
1414K09	14	14	125	13	14	14				●	●	216305
1616K09	16	16	125	13	16	16				●	●	216306

SCFCR

Cylindrical Turning

End Face Turning

(Inserts): A15-A16 (Toolholder Parts): P01-P04



Ordering code	Dimensions						Insert	Wrench	Screw	Stock		Order Number
	h	b	L	L1	h1	f				R	L	
SCFCR/L 1212H06	12	12	100	16	12	16	CC..0602..	T8	M2.5×7	●	●	215600
1414H09	14	14	100	20	14	16				●	●	215601
1616H09	16	16	100	20	16	20				●	●	215602
2020K09	20	20	125	20	20	25				●	●	215604
2525M12	25	25	150	25	25	32				●	●	215606
3232P12	32	32	170	25	32	40	CC..1204..	T20	M5×12	●	●	215608

SCGCR

Cylindrical Turning

End Face Turning

(Inserts): A15-A16 (Toolholder Parts): P01-P04



Ordering code	Dimensions						Insert	Wrench	Screw	Stock		Order Number
	h	b	L	L1	h1	f				R	L	
SCGCR/L 0808F06	8	8	80	10	8	10	CC..0602..	T8	M2.5×7	●	●	215450
1010H06	10	10	100	12	10	12				●	●	215452
1212H06	12	12	100	12	12	16				●	●	215453
1212H09	12	12	100	18	12	16				●	●	215454
1616H09	16	16	100	18	16	20				●	●	215456
2020K09	20	20	125	20	20	25	CC..09T3..	T15	M4×10	●	●	215458
2525M09	25	25	150	24	25	32				●	●	215450
2020K12	20	20	125	23	20	25				●	●	215452
2525M12	25	25	150	26	25	32				●	●	215454
3232P12	32	32	170	28	32	40				CC..1204..	T20	M5×12

SCLCR

Cylindrical Turning

End Face Turning

(Inserts): A15-A16 (Toolholder Parts): P01-P04



Ordering code	Dimensions						Insert	Wrench	Screw	Stock		Order Number
	h	b	L	L1	h1	f				R	L	
SCLCR/L 0808F06	8	8	80	10	8	10	CC..0602..	T8	M2.5×7	●	●	215400
1010H06	10	10	100	12	10	12				●	●	215402
1212H06	12	12	100	12	12	16				●	●	215403
1212H09	12	12	100	18	12	16				●	●	215404
1414H09	14	14	100	18	14	16				●	●	215405
1616H09	16	16	100	18	16	20	CC..09T3..	T15	M4×10	●	●	215406
2020K09	20	20	125	20	20	25				●	●	215408
2525M09	25	25	150	24	25	32				●	●	215410
2020K12	20	20	125	23	20	25				●	●	215412
2525M12	25	25	150	26	25	32				CC..1204..	T20	M5×12
3232P12	32	32	170	28	32	40	●	●	215416			

SCMCN..80

Cylindrical Turning

(Inserts): A15-A16 (Toolholder Parts): P01-P04



Ordering code	Dimensions						Insert	Wrench	Screw	Stock		Order Number
	h	b	L	L1	h1	f				R	L	
SCMCN 0808H06	8	8	100	13	8	4	CC..0602..	T8	M2.5×7	●	●	215701
1010H06	10	10	100	13	10	5				●	●	215700
1212H09	12	12	100	18	12	6				●	●	215702
1414H09	14	14	100	18	14	7				●	●	215703
1616H09	16	16	100	18	16	8				CC..09T3..	T15	M4×10
2020K09	20	20	125	18	20	10	●	●	215706			
2525M09	25	25	150	18	25	12.5	●	●	215708			
2020K12	20	20	125	23	20	20	●	●	215710			
2525M12	25	25	150	23	25	12.5	CC..1204..	T20	M5×12			

SCMCN..100

Cylindrical Turning

(Inserts): A15-A16 (Toolholder Parts): P01-P04

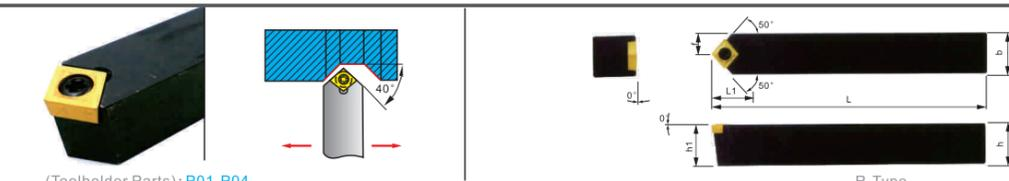

Ordering code	Dimensions						Insert	Wrench	Screw	Stock		Order Number			
	h	b	L	L1	h1	f				R	L				
SCMCN 1010H06-100	10	10	100	13	10	5	CC..0602..	T8	M2.5×7	●	●	216100			
1212H09-100	12	12	100	18	12	6				●	●	216102			
1414H09-100	14	14	100	18	14	7				●	●	216103			
1616H09-100	16	16	100	18	16	8				CC..09T3..	T15	M4×10	●	●	216104
2020K09-100	20	20	125	18	20	10							●	●	216106
2525M09-100	25	25	150	18	25	12.5	●	●	216108						
2020K12-100	20	20	125	23	20	20	●	●	216110						
2525M12-100	25	25	150	23	25	12.5	CC..1204..	T20	M5×12				●	●	216112

SCBCR

Cylindrical Turning

(Inserts): A15-A16 (Toolholder Parts): P01-P04



Ordering code	Dimensions						Insert	Wrench	Screw	Stock		Order Number
	h	b	L	L1	h1	f				R	L	
SCBCR/L 1212H09	12	12	100	13	12	9.5	CC..09T3..	T15	M4×10	●	●	216196
1616H09	16	16	100	15	16	13				●	●	216198
2020K09	20	20	125	12	20	17				●	●	216200
2525M09	25	25	150	12	25	22				●	●	216202
1616H12	16	16	100	20	16	13				CC..1204..	T20	M5×12
2020K12	20	20	125	16	20	17	●	●	216204			
2525M12	25	25	150	16	25	22	●	●	216206			

SCKCR

End Face Turning

(Inserts): A15-A16 (Toolholder Parts): P01-P04



Ordering code	Dimensions						Insert	Wrench	Screw	Stock		Order Number
	h	b	L	L1	h1	f				R	L	
SCKCR/L 1212H09	12	12	100	20	12	16	CC..09T3..	T15	M4×10	●	●	215500
1414H09	14	14	100	20	14	16				●	●	215501
1616H09	16	16	100	20	16	20				●	●	215502
2020K09	20	20	125	23	20	25				●	●	215504
2525M09	25	25	150	23	25	32				CC..1204..	T20	M5×12
2020K12	20	20	125	23	20	25	●	●	215508			
2525M12	25	25	150	25	25	32	●	●	215510			

SDACR

Cylindrical Turning
End Face Turning



(Inserts): A17-A18 (Toolholder Parts): P01-P04 R-Type

Ordering code	Dimensions						Insert	Wrench	Screw	Stock		Order Number
	h	b	L	L1	h1	f				R	L	
SDACR/L 0808H07	8	8	100	15	8	8	DC..0702..	T8	M2.5×7	•	•	216500
1010H07	10	10	100	15	10	10				•	•	216502
1212H07	12	12	100	15	12	12				•	•	216504
1212H11	12	12	100	22	12	12				•	•	216506
1414H11	14	14	100	22	14	14				•	•	216507
1616H11	16	16	100	22	16	16	DC..11T3..	T15	M4×10	•	•	216508
2020K11	20	20	125	22	20	20				•	•	216510
2525M11	25	25	150	22	25	25				•	•	216512

SDFCR

Cylindrical Turning
End Face Turning

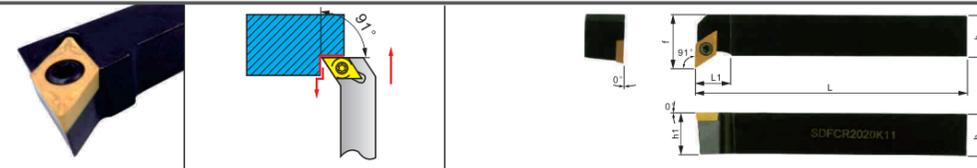

(Inserts): A17-A18 (Toolholder Parts): P01-P04 R-Type

Ordering code	Dimensions						Insert	Wrench	Screw	Stock		Order Number
	h	b	L	L1	h1	f				R	L	
SDFCR/L 1212H07	12	12	100	8	12	16	DC..0702..	T8	M2.5×7	•	•	216600
1616H11	16	16	100	14	16	20				•	•	216602
2020K11	20	20	125	14	20	25				•	•	216604

SDJCR

Cylindrical Turning
End Face Turning



(Inserts): A17-A18 (Toolholder Parts): P01-P04 R-Type

Ordering code	Dimensions						Insert	Wrench	Screw	Stock		Order Number
	h	b	L	L1	h1	f				R	L	
SDJCR/L 1010H07	10	10	100	14	10	12	DC..0702..	T8	M2.5×7	•	•	216400
1212H07	12	12	100	14	12	16				•	•	216402
1616H07	16	16	100	14	16	20				•	•	216404
1212H11	12	12	100	20	12	16				•	•	216406
1414H11	14	14	100	20	14	16				•	•	216407
1616H11	16	16	100	20	16	20	DC..11T3..	T15	M4×10	•	•	216408
2020K11	20	20	125	20	20	25				•	•	216410
2525M11	25	25	150	22	25	32				•	•	216412
3232P11	32	32	170	23	32	40				•	•	216414
4040R11	40	40	200	25	40	50				•	•	216416

SDNCN

Cylindrical Turning

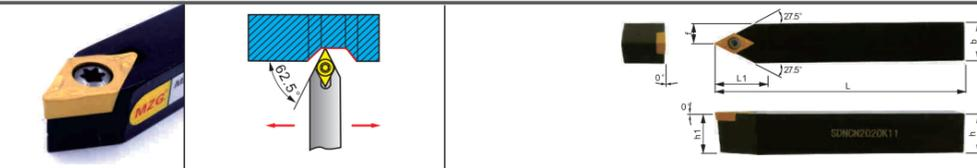

(Inserts): A17-A18 (Toolholder Parts): P01-P04 R-Type

Ordering code	Dimensions						Insert	Wrench	Screw	Stock		Order Number
	h	b	L	L1	h1	f				R	L	
SDNCN 1010H07	10	10	100	14	10	5	DC..0702..	T8	M2.5×7	•	•	216712
1212H07	12	12	100	14	12	6				•	•	216714
1212H11	12	12	100	21	12	6				•	•	216716
1414H11	14	14	100	21	14	7				•	•	216717
1616H11	16	16	100	21	16	8				•	•	216718
2020K11	20	20	125	21	20	10	•	•	216720			

SDQCR

Cylindrical Turning
End Face Turning



(Inserts): A17-A18 (Toolholder Parts): P01-P04 R-Type

Ordering code	Dimensions						Insert	Wrench	Screw	Stock		Order Number
	h	b	L	L1	h1	f				R	L	
SDQCR/L 1010H07	10	10	100	13	10	12	DC..0702..	T8	M2.5×7	•	•	216700
1212H07	12	12	100	13	12	16				•	•	216702
1212H11	12	12	100	14	12	16				•	•	216704
1616H11	16	16	100	14	16	20				•	•	216706
2020K11	20	20	125	16	20	25				•	•	216708
2525M11	25	25	150	20	25	32	DC..11T3..	T15	M4×10	•	•	216710

SSBCR

Cylindrical Turning

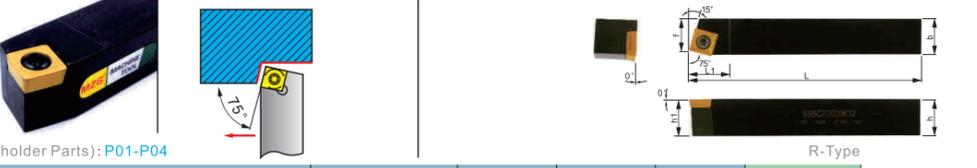

(Inserts): A20 (Toolholder Parts): P01-P04 R-Type

Ordering code	Dimensions						Insert	Wrench	Screw	Stock		Order Number
	h	b	L	L1	h1	f				R	L	
SSBCR/L 1212H09	12	12	100	14	12	9.5	SC..09T3..	T15	M4×10	•	•	217100
1616H09	16	16	100	14	16	13				•	•	217102
2020K09	20	20	125	30	20	17				•	•	217104
2525M09	25	25	150	32	25	22				•	•	217106
2020K12	20	20	125	30	20	17				SC..1204..	T20	M5×12
2525M12	25	25	150	25	22	22	•	•	217110			

SSKCR

End Face Turning

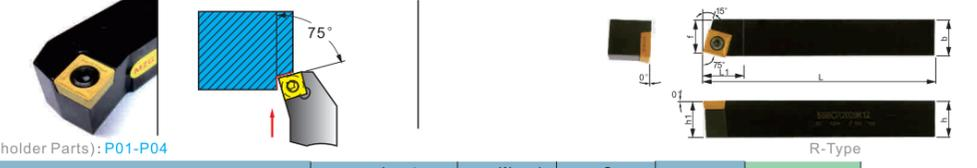

(Inserts): A20 (Toolholder Parts): P01-P04 R-Type

Ordering code	Dimensions						Insert	Wrench	Screw	Stock		Order Number
	h	b	L	L1	h1	f				R	L	
SSKCR/L 1212H09	12	12	100	15	12	16	SC..09T3..	T15	M4×10	•	•	217198
1616H09	16	16	100	20	16	20				•	•	217200
2020K09	20	20	125	25	20	25				•	•	217202
2525M09	25	25	150	22	25	32				•	•	217204
2020K12	20	20	125	20	20	25				SC..1204..	T20	M5×12

SSSCR

Cylindrical Turning



(Inserts): A20 (Toolholder Parts): P01-P04 R-Type

Ordering code	Dimensions						Insert	Wrench	Screw	Stock		Order Number
	h	b	L	L1	h1	f				R	L	
SSSCR/L 1212H09	12	12	100	16	12	16	SC..09T3..	T15	M4×10	•	•	217300
1616H09	16	16	100	16	16	20				•	•	217301
2020K09	20	20	125	18	20	25				•	•	217302
2525M09	25	25	150	26	25	32				•	•	217303
2525M12	25	25	150	25	25	32				SC..1204..	T20	M5×12

SSDCN

Cylindrical Turning



(Inserts): A20 (Toolholder Parts): P01-P04 R-Type

Ordering code	Dimensions						Insert	Wrench	Screw	Stock		Order Number
	h	b	L	L1	h1	f				R	L	
SSDCN 1212H09	12	12	100	16	12	6	SC..09T3..	T15	M4×10	•	•	217400
1414H09	14	14	100	16	14	7				•	•	217401
1616H09	16	16	100	16	16	8				•	•	217402
2020K09	20	20	125	16	20	10				•	•	217404
2525M09	25	25	150	16	25	12.5				•	•	217406

SRAP(C)R

Cylindrical Turning



(Inserts): A19 (Toolholder Parts): P01-P04 R-Type

Ordering code	Dimensions						Insert	Wrench	Screw	Stock		Order Number	
	h	b	L	L1	h1	f				R	L		
SRAP(C)R/L	1616H08	16	16	100	16	16	16.5	RP..08T2..	T10	M3×8	●	●	218500
	2020K08	20	20	125	16	20	20.5				●	●	218502
	2525M08	25	25	150	16	25	25.5				●	●	218504
SRAP(C)R/L	2020K10	20	20	125	20.3	20	20.6	RP..10T3..	T15	M3.5×10	●	●	218506
	2525M10	25	25	150	20.3	25	25.6				●	●	218508
	2020K12	20	20	125	25	20	20.8				●	●	218510
2525M12	25	25	150	25	25	25.8	RP..1204..	T15	M4×10	●	●	218512	

SRDP(C)N

Cylindrical Turning



(Inserts): A19 (Toolholder Parts): P01-P04 R-Type

Ordering code	Dimensions						Insert	Wrench	Screw	Stock		Order Number	
	h	b	L	L1	h1	f				R	L		
SRDP(C)N	1616H08	16	16	100	16	16	8	RP..08T2..	T10	M3×8	●	●	218700
	2020K08	20	20	125	16	20	10				●	●	218702
	2525M08	25	25	150	16	25	12.5				●	●	218704
SRDP(C)N	1010H10	10	10	100	20.3	10	5	RP..10T3..	T15	M3.5×10	●	●	218706
	1616H10	16	16	100	20.3	16	8				●	●	218708
	2020K10	20	20	125	20.3	20	10				●	●	218710
2525M10	25	25	150	20.3	25	12.5	●	●	218712				
3232P10	32	32	170	20.3	32	16	●	●	218714				
2020K12	20	20	125	25	20	10	RP..1204..	T15	M4×10	●	●	218716	
2525M12	25	25	150	25	25	12.5	●	●	218718				

SRGP(C)R

Cylindrical Turning

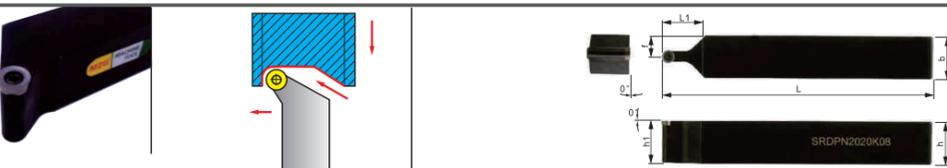

(Inserts): A19 (Toolholder Parts): P01-P04 R-Type

Ordering code	Dimensions						Insert	Wrench	Screw	Stock		Order Number	
	h	b	L	L1	h1	f				R	L		
SRGP(C)R/L	1212H05	12	12	100	9.5	12	16	RP..0502..	T6	M2.2×6	●	●	218600
	1616H05	16	16	100	9.5	16	20				●	●	218602
	2020K05	20	20	125	11.2	20	25				●	●	218604
	2525M05	25	25	150	14.7	25	32				●	●	218606
SRGP(C)R/L	1212H06	12	12	100	10	12	16	RP..0602..	T8	M2.5×6	●	●	218608
	1616H06	16	16	100	10	16	20				●	●	218610
	2020K06	20	20	125	12	20	25				●	●	218612
	2525M06	25	25	150	15	25	32				●	●	218614
SRGP(C)R/L	1616H08	16	16	100	11	16	20	RP..08T2..	T8	M3×8	●	●	218616
	2020K08	20	20	125	12.7	20	25				●	●	218618
	2525M08	25	25	150	16.2	25	32				●	●	218620
	1616H10	16	16	100	11	16	20				●	●	218622
SRGP(C)R/L	2020K10	20	20	125	12.7	20	25	RP..10T3..	T8	M4×10	●	●	218624
	2525M10	25	25	150	16.2	25	32				●	●	218626
2020K12	20	20	125	13	20	25	RP..1204..	T15	M4×10	●	●	218628	
2525M12	25	25	150	17	25	32				●	●	218630	

STECR

Cylindrical Turning

End Face Turning



(Inserts): A21-A22 (Toolholder Parts): P01-P04 R-Type

Ordering code	Dimensions						Insert	Wrench	Screw	Stock		Order Number	
	h	b	L	L1	h1	f				R	L		
STECR/L	1616H11	16	16	100	80	10	16	TC..1102..	T8	M2.5×7	●	●	217700
	2020K11	20	20	125	100	12	20				●	●	217702
	2525M11	25	25	150	120	16	25				●	●	217704
	2020K16	20	20	125	100	16	20				●	●	217706
STECR/L	2525M16	25	25	150	120	20	25	TC..16T3..	T15	M3.5×9	●	●	217708
	3232P16	32	32	170	135	25	32				●	●	217710

STGCR

Cylindrical Turning

End Face Turning



(Inserts): A21-A22 (Toolholder Parts): P01-P04 R-Type

Ordering code	Dimensions						Insert	Wrench	Screw	Stock		Order Number	
	h	b	L	L1	h1	f				R	L		
STGCR/L	0808H09	8	8	100	10	8	10	TC..0902..	T6	M2.2×6	●	●	217600
	1010H09	10	10	100	12	10	12				●	●	217602
	1212H11	12	12	100	16	12	16				●	●	217604
STGCR/L	1616H11	16	16	100	20	12	20	TC..1102..	T8	M2.5×7	●	●	217606
	1616H16	16	16	100	22	16	20				●	●	217609
	2020K16	20	20	125	22	20	25				●	●	217608
2525M16	25	25	150	22	20	32	TC..16T3..	T15	M4×10	●	●	217610	
3232P16	32	32	170	22	25	40				●	●	217612	

STFCR

Cylindrical Turning

End Face Turning

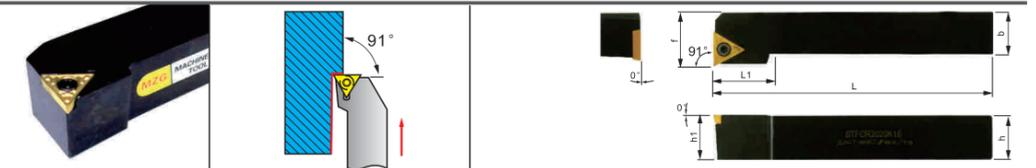

(Inserts): A21-A22 (Toolholder Parts): P01-P04 R-Type

Ordering code	Dimensions						Insert	Wrench	Screw	Stock		Order Number	
	h	b	L	L1	h1	f				R	L		
STFCR/L	1010H09	10	10	100	12	10	12	TC..0902..	T6	M2.2×6	●	●	217500
	1212H11	12	12	100	16	12	16				●	●	217502
	1414H11	14	14	100	16	14	16				●	●	217503
STFCR/L	1616H11	16	16	100	16	16	20	TC..1102..	T8	M2.5×7	●	●	217504
	1616H16	16	16	100	16	16	20				●	●	217506
	2020K16	20	20	125	22	20	25				●	●	217508
2525M16	25	25	150	22	25	32	TC..16T3..	T15	M4×10	●	●	217510	

STWCR

Cylindrical Turning

End Face Turning



(Inserts): A21-A22 (Toolholder Parts): P01-P04 R-Type

Ordering code	Dimensions						Insert	Wrench	Screw	Stock		Order Number	
	h	b	L	L1	h1	f				R	L		
STWCR/L	1212H11	12	12	100	8	12	15.3	TC..1102..	T8	M2.5×7	●	●	217712
	1616H11	16	16	100	8	16	19.3				●	●	217714
	2020K11	20	20	125	8	20	23.3				●	●	217716
	2525M11	25	25	150	8	25	28.3				●	●	217718
STWCR/L	1616H16	16	16	100	12	16	21	TC..16T3..	T15	M4×10	●	●	217720
	2020K16	20	20	125	12	20	26				●	●	217722
	2525M16	25	25	150	12	25	31				●	●	217724
	3232P16	32	32	170	12	32	38				●	●	217726

SVJBR

Cylindrical Turning
End Face Turning



(Inserts): A23-A24 (Toolholder Parts): P01-P04 R-Type

Ordering code	Dimensions						Insert	Wrench	Screw	Stock		Order Number
	h	b	L	L1	h1	f				R	L	
SVJBR/L 1212H11	12	12	100	25	12	16	VB..1103..	T8	M2.5×6	●	●	218108
1616H11	16	16	100	28	16	20				●	●	218110
2020K11	20	20	125	32	20	25				●	●	218112
1616H16	16	16	100	32	16	20	VB..1604..	T15	M4×10	●	●	218100
2020K16	20	20	125	32	20	25				●	●	218102
2525M16	25	25	150	32	25	32				●	●	218104
3232P16	32	32	170	40	32	40				●	●	218106

SVJCR

Cylindrical Turning
End Face Turning



(Inserts): A23-A24 (Toolholder Parts): P01-P04 R-Type

Ordering code	Dimensions						Insert	Wrench	Screw	Stock		Order Number
	h	b	L	L1	h1	f				R	L	
SVJCR/L 1212H11	12	12	100	25	12	16	VC..1103..	T8	M2.5×6	●	●	218158
1616H11	16	16	100	28	16	20				●	●	218160
2020K11	20	20	125	32	20	25				●	●	218162
1616H16	16	16	100	32	16	20	VC..1604..	T15	M4×10	●	●	218170
2020K16	20	20	125	32	20	25				●	●	218172
2525M16	25	25	150	32	25	32				●	●	218174
3232P16	32	32	170	40	32	40				●	●	218176

SVQBR

Cylindrical Turning
End Face Turning



(Inserts): A23-A24 (Toolholder Parts): P01-P04 R-Type

Ordering code	Dimensions						Insert	Wrench	Screw	Stock		Order Number
	h	b	L	L1	h1	f				R	L	
SVQBR/L 1212H11	12	12	100	25	12	16	VB..1103..	T8	M2.5×6	●	●	218301
1616H11	16	16	100	28	16	20				●	●	218303
2020K11	20	20	125	32	20	25				●	●	218305
1616H16	16	16	100	32	16	20	VB..1604..	T15	M4×10	●	●	218300
2020K16	20	20	125	32	20	25				●	●	218302
2525M16	25	25	150	32	25	32				●	●	218304
3232P16	32	32	170	40	32	40				●	●	218306

SVQCR

Cylindrical Turning
End Face Turning



(Inserts): A23-A24 (Toolholder Parts): P01-P04 R-Type

Ordering code	Dimensions						Insert	Wrench	Screw	Stock		Order Number
	h	b	L	L1	h1	f				R	L	
SVQCR/L 1212H11	12	12	100	25	12	16	VC..1103..	T8	M2.5×6	●	●	218351
1616H11	16	16	100	28	16	20				●	●	218353
2020K11	20	20	125	32	20	25				●	●	218355
1616H16	16	16	100	32	16	20	VC..1604..	T15	M4×10	●	●	218350
2020K16	20	20	125	32	20	25				●	●	218352
2525M16	25	25	150	32	25	32				●	●	218354
3232P16	32	32	170	40	32	40				●	●	218356

SVUBR

Cylindrical Turning
End Face Turning



(Inserts): A23-A24 (Toolholder Parts): P01-P04 R-Type

Ordering code	Dimensions						Insert	Wrench	Screw	Stock		Order Number
	h	b	L	L1	h1	f				R	L	
SVUBR/L 1212H11	12	12	100	12	12	16	VB..1103..	T8	M2.5×6	●	●	218318
1616H11	16	16	100	12	16	20				●	●	218320
2020K11	20	20	125	16	20	25				●	●	218312
1616H16	16	16	100	20	16	30	VB..1604..	T15	M4×10	●	●	218310
2020K16	20	20	125	20	20	30				●	●	218312
2525M16	25	25	150	16	25	32				●	●	218314
3232P16	32	32	170	16	32	40				●	●	218316

SVUCR

Cylindrical Turning
End Face Turning



(Inserts): A23-A24 (Toolholder Parts): P01-P04 R-Type

Ordering code	Dimensions						Insert	Wrench	Screw	Stock		Order Number
	h	b	L	L1	h1	f				R	L	
SVUCR/L 1212H11	12	12	100	12	12	16	VC..1103..	T8	M2.5×6	●	●	218358
1616H11	16	16	100	12	16	20				●	●	218360
2020K11	20	20	125	16	20	25				●	●	218362
1616H16	16	16	100	20	16	30	VC..1604..	T15	M4×10	●	●	218370
2020K16	20	20	125	20	20	30				●	●	218372
2525M16	25	25	150	16	25	32				●	●	218374
3232P16	32	32	170	16	32	40				●	●	218376

SVVBN

Cylindrical Turning



(Inserts): A23-A24 (Toolholder Parts): P01-P04 R-Type

Ordering code	Dimensions						Insert	Wrench	Screw	Stock		Order Number
	h	b	L	L1	h1	f				R	L	
SVVBN 1010H11	10	10	100	25	10	5	VB..1103..	T8	M2.5×7	●	●	218201
1212H11	12	12	100	28	12	6				●	●	218203
1616H11	16	16	100	24	16	8				●	●	218200
2020K11	20	20	125	24	20	10				●	●	218202
2525M11	25	25	150	24	25	12.5	VB..1604..	T15	M4×10	●	●	218204
1616H16	16	16	100	34	16	8				●	●	218206
2020K16	20	20	125	34	20	10				●	●	218208
2525M16	25	25	150	34	25	12.5				●	●	218210
3232P16	32	32	170	34	32	16				●	●	218212

SVVCN

Cylindrical Turning



(Inserts): A23-A24 (Toolholder Parts): P01-P04 R-Type

Ordering code	Dimensions						Insert	Wrench	Screw	Stock		Order Number
	h	b	L	L1	h1	f				R	L	
SVVCN 1010H11	10	10	100	25	10	5	VC..1103..	T8	M2.5×7	●	●	218251
1212H11	12	12	100	28	12	6				●	●	218253
1616H11	16	16	100	24	16	8				●	●	218250
2020K11	20	20	125	24	20	10				●	●	218252
2525M11	25	25	150	24	25	12.5	VC..1604..	T15	M4×10	●	●	218254
1616H16	16	16	100	34	16	8				●	●	218256
2020K16	20	20	125	34	20	10				●	●	218258
2525M16	25	25	150	34	25	12.5				●	●	218260
3232P16	32	32	170	34	32	16				●	●	218262

Inner hole turning tool system

	MTWNR B37	STWNR B37	STWC(P)R B56
	TN... Ø20-Ø32	TN... Ø16-Ø20	TN... Ø8-Ø25
	60° 60°	60° 60°	60° 60°
	C-STWCR B56	T-STWCR B56	H-STWCR B56
	TC... Ø8-Ø20	TC... Ø8-Ø25	TC... Ø8-Ø25
	60° 60°	60° 60°	60° 60°
	MCWNR B36	SCWCR B47	H-SCWCR B47
	CN... Ø20-Ø40	CC... Ø8-Ø20	CC... Ø8-Ø20
	80° 50°	80° 50°	80° 50°
	MSSNR B40	SSSCR B54	H-SSSCR B54
	SN... Ø20-Ø50	SC... Ø12-Ø32	SC... Ø12-Ø25
	90° 45°	90° 45°	90° 45°
	MDWNR B41	SDWCR B53	
	DN... Ø20-Ø40	DC... Ø10-Ø32	
	55° 62.5°	55° 55°	
	MVWNR B43	SVWB(C)R B65	
	VN... Ø25-Ø32	VB/VC... Ø25-Ø32	
	35° 72.5°	35° 72.5°	

	SBXR AB29	SCZCR B47	MDZNR B41	SDZCR B51
	CC... Ø4-Ø8	DN... Ø8-Ø25	DN... Ø25-Ø40	DC... Ø10-Ø32
	C-SDZCR B51	MVZNR B43	SVZB(C)R B64	C-SVZB(C)R B64
	DC... Ø10-Ø25	VN... Ø25-Ø32	VB/VC... Ø16-Ø40	VB/VC... Ø16-Ø25

	MCKNR B36	DCKNR B36	ECKNR B36	SCKNR B36	SCKCR B48	C-SCKCR B48
	CN... Ø20-Ø50	CN... Ø20-Ø40	CN... Ø32-Ø40	CN... Ø16-Ø25	CC... Ø8-Ø25	CC... Ø8-Ø20
	T-SCKCR B48	H-SCKCR B48	MSKNR B40	DSKNR B40	SSKCR B54	C-SSKCR B54
	CC... Ø8-Ø25	CC... Ø8-Ø25	SN... Ø20-Ø50	SN... Ø20-Ø50	SC... Ø12-Ø25	SC... Ø12-Ø25

	DS-LBMB AB05	S-SVNR AB05	SVN AB08	CH-LBML AB08	LBMAR AB08
	LBM... Ø14-Ø25	VNBR... Ø12-Ø25	VNBR... Ø10-Ø25	LBM... Ø10-Ø12	LBM... Ø10-Ø16
	SBQR AB28	SBPR AB28	SBFR AB28	SBTR AB28	SBUR AB28
	35° Ø4-Ø8	60° Ø4-Ø8	70° Ø4-Ø8	80° Ø4-Ø8	90° Ø4-Ø8
	SBDR AB29	STIR AB28	SBWR AB29	SBKR AB29	SBCR AB29
	93° 44° CSV... Ø4-Ø8	30° 55°/60° CSV... Ø4-Ø8	CSV... Ø4-Ø8	CSV... Ø4-Ø8	45° 90° CSV... Ø4-Ø8
	SMFR AB29	SMFL AB29	SMVR AB29		
	Ø6-Ø10	Ø6-Ø10	Ø6-Ø10		

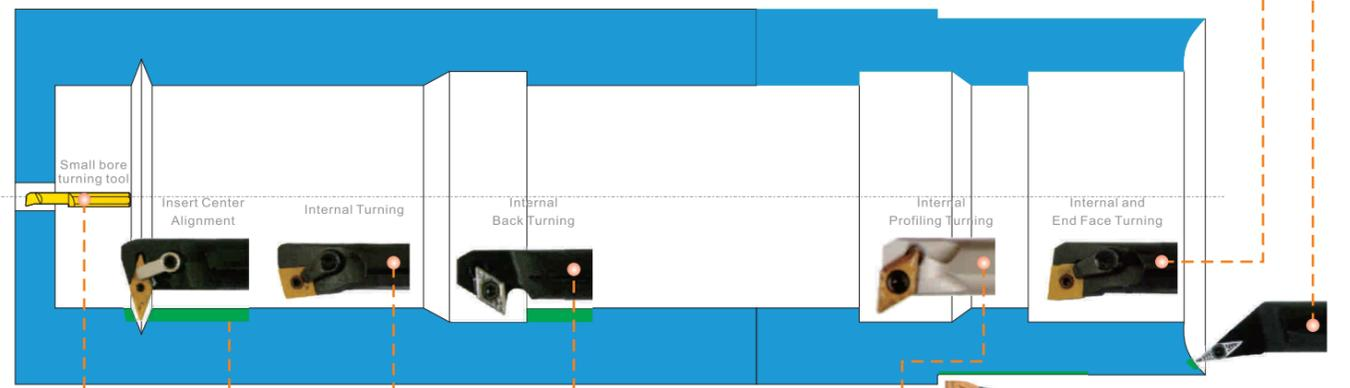

	MTJNR B38	SDJCR B49	C-SDJCR B49	T-SDJCR B49	H-SDJCR B49	SDXCR B50
	TN... Ø20-Ø40	DC... Ø8-Ø25	DC... Ø8-Ø25	DC... Ø8-Ø25	DC... Ø8-Ø25	DC... Ø8-Ø25
	C-SDXCR B50	T-SDXCR B50	H-SDXCR B50	MVXNR B42	DVXNR B42	EVXNR B42
	DC... Ø8-Ø25	DC... Ø8-Ø25	DC... Ø8-Ø25	VN... Ø20-Ø40	VN... Ø20-Ø40	VN... Ø32-Ø40
	SVJB(C)R B61	C-SVJB(C)R B61	SVXB(C)R B62	C-SVXB(C)R B62		
	VB/VC... Ø8-Ø40	VB/VC... Ø8-Ø25	VB/VC... Ø8-Ø40	VB/VC... Ø8-Ø25		

	MCLNR B35	DCLNR B35	ECLNR B35	SCLNR B35	C-MCLNR B35	SCLCR-A B46
	CN... Ø16-Ø60	CN... Ø20-Ø40	CN... Ø32-Ø40	CN... Ø16-Ø20	CN... Ø16-Ø32	CC... Ø7-Ø16
	SCLCR B45	C-SCLCR B45	E-SCLCR B45	T-SCLCR B46	H-SCLCR B46	C-SCLCR-A B46
	CC... Ø7-Ø40	CC... Ø4-Ø25	CC... Ø5-Ø20	CC... Ø7-Ø25	CC... Ø4-Ø25	CC... Ø4-Ø8
	MTLNR B38	ETLNR B38	STLNR B38	MTUNR B39	DTUNR B39	WTUNR B39
	TN... Ø18-Ø32	TN... Ø20-Ø40	TN... Ø16-Ø20	TN... Ø16-Ø60	TN... Ø16-Ø40	TN... Ø25-Ø50
	STUNR B39	STUBR B55	C-STUBR B55	H-STUBR B55	E-STUBR B55	STUP(C)R-A B55
	TN... Ø16-Ø20	TB... Ø6-Ø16	TB... Ø6-Ø8	TB... Ø6-Ø16	TB... Ø6-Ø8	TC/TP... Ø7-Ø12
	STUCR B57	C-STUCR B57	E-STUCR B57	T-STUCR B57	H-STUCR B57	STUPR B58
	TC... Ø8-Ø32	TC... Ø8-Ø25	TC... Ø8-Ø20	TC... Ø8-Ø25	TC... Ø8-Ø25	TP... Ø8-Ø32

	MTQNR B38	ETQNR B38	STQNR B38		
	TN... Ø20-Ø40	TN... Ø20-Ø40	TN... Ø16-Ø20		
	MDQNR B40	DDQNR B40	EDQNR B40	SDQCR B51	C-SDQCR B51
	DN... Ø20-Ø40	DN... Ø20-Ø40	DN... Ø32-Ø40	DC... Ø8-Ø32	DC... Ø10-Ø25
	MVQNR B42	DVQNR B42	EVQNR B42	SVQB(C)R B65	C-SVQB(C)R B65
	VN... Ø20-Ø40	VN... Ø20-Ø40	VN... Ø32-Ø40	VB/VC... Ø16-Ø40	VB/VC... Ø16-Ø20

	MCLNR B35	DCLNR B35	ECLNR B35	SCLNR B35	C-MCLNR B35	SCLCR-A B46
	CN... Ø16-Ø60	CN... Ø20-Ø40	CN... Ø32-Ø40	CN... Ø16-Ø20	CN... Ø16-Ø32	CC... Ø7-Ø16
	SCLCR B45	C-SCLCR B45	E-SCLCR B45	T-SCLCR B46	H-SCLCR B46	C-SCLCR-A B46
	CC... Ø7-Ø40	CC... Ø4-Ø25	CC... Ø5-Ø20	CC... Ø7-Ø25	CC... Ø4-Ø25	CC... Ø4-Ø8
	MTLNR B38	ETLNR B38	STLNR B38	MTUNR B39	DTUNR B39	WTUNR B39
	TN... Ø18-Ø32	TN... Ø20-Ø40	TN... Ø16-Ø20	TN... Ø16-Ø60	TN... Ø16-Ø40	TN... Ø25-Ø50
	STUNR B39	STUBR B55	C-STUBR B55	H-STUBR B55	E-STUBR B55	STUP(C)R-A B55
	TN... Ø16-Ø20	TB... Ø6-Ø16	TB... Ø6-Ø8	TB... Ø6-Ø16	TB... Ø6-Ø8	TC/TP... Ø7-Ø12
	STUCR B57	C-STUCR B57	E-STUCR B57	T-STUCR B57	H-STUCR B57	STUPR B58
	TC... Ø8-Ø32	TC... Ø8-Ø25	TC... Ø8-Ø20	TC... Ø8-Ø25	TC... Ø8-Ø25	TP... Ø8-Ø32
	MDUNR B41	DDUNR B41	EDUNR B41	SDUCR B52	C-SDUCR B52	T-SDUCR B52
	DN... Ø20-Ø40	DN... Ø20-Ø40	DN... Ø32-Ø40	DC... Ø8-Ø32	DC... Ø10-Ø25	DC... Ø8-Ø25
	H-SDUCR B52	MVUNR B43	DVUNR B43	EVUNR B43	SVUB(C)R B63	C-SVUB(C)R B63
	DC... Ø8-Ø25	VN... Ø20-Ø40	VN... Ø20-Ø40	VN... Ø32-Ø40	VB/VC... Ø16-Ø40	VB/VC... Ø16-Ø25
	MWLNR B44	DWLNR B44	EWLNR B44	SWLNR B44	SWUBR B66	SWLCR B66
	WN... Ø16-Ø60	WN... Ø20-Ø40	WN... Ø25-Ø50	WN... Ø16-Ø20	WB... Ø6-Ø16	WC... Ø8-Ø25

Boring Tools

- $\phi 2$. 2-
- SBFS SBFB
- R R0.05 R0.15



Groove Machining

Thread Cutting

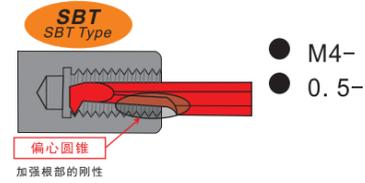
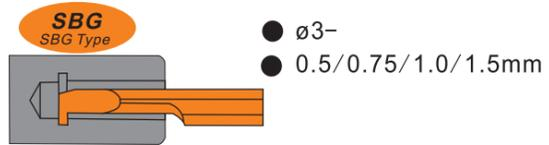

Alloy Small Boring Tool

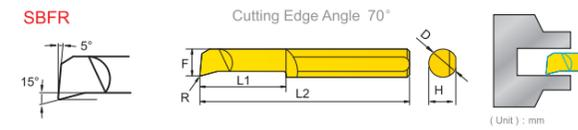
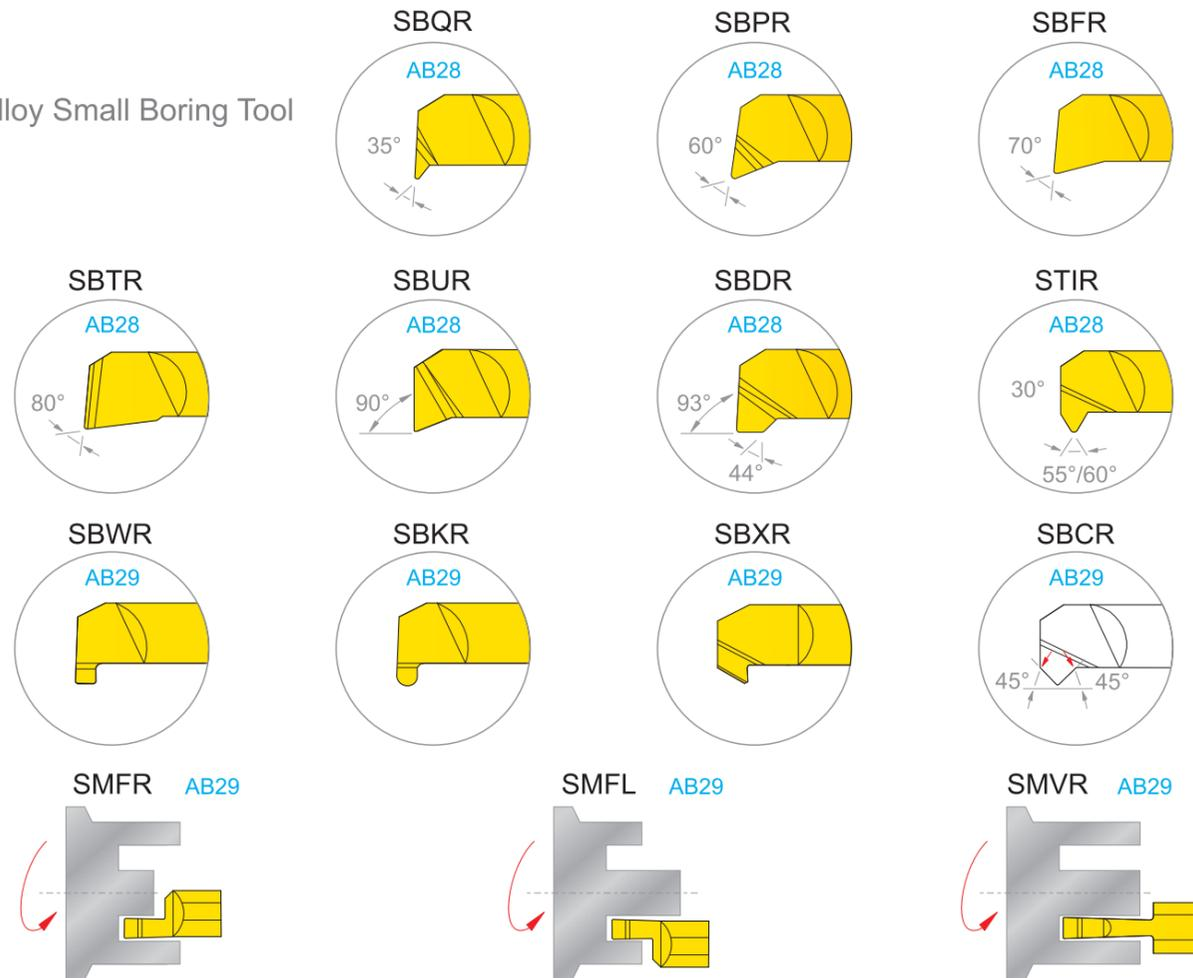

Model	F	L1	S	R	D	L2	H	Stock	Processing Diameter	Order No.
SBFR1003R005-D4	0.8	3.0	0.2	0.05	D4	40	3.7	○	1mm	207131
SBFR1505R010-D4	1.2	5.0	0.2	0.1	D4	40	3.7	○	1.5mm	207132
SBFR2007R010-D4	1.7	7.0	0.35	0.1	D4	40	3.7	○	2mm	207133
SBFR2507R010-D4	2.3	7.0	0.45	0.1	D4	40	3.7	○	2.5mm	207134
SBFR3010R010-D4	2.7	10.0	0.45	0.1	D4	50	3.7	○	3mm	207135
SBFR3515R015-D4	3.2	15.0	0.5	0.15	D4	50	3.7	○	3.5mm	207136
SBFR4015R015-D4	3.7	15.0	0.5	0.15	D4	50	3.7	○	4mm	207137
SBFR4515R015-D4	4.0	15.0	0.5	0.15	D4	50	3.7	○	4.5mm	207138
SBFR5020R020-D6	4.7	20.0	0.9	0.20	D6	50	5.7	○	5mm	207139
SBFR5520R020-D6	5.2	20.0	0.9	0.20	D6	50	5.7	○	5.5mm	207140
SBFR6020R020-D6	5.7	20.0	0.9	0.20	D6	50	5.7	○	6mm	207141
SBFR8040R020-D8	7.5	40.0	1.2	0.20	D8	60	7.7	○	8mm	207142

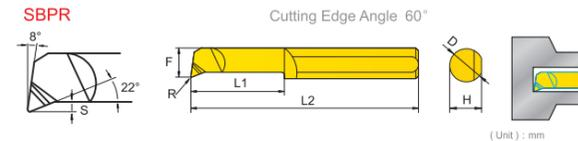

Model	F	L1	S	R	D	L2	H	Stock	Processing Diameter	Order No.
SBPR 1004R005-D4	0.85	4.0	0.15	0.00	D4	40	3.7	○	1mm	207145
SBPR 1004R005-D4	0.85	4.0	0.15	0.00	D4	40	3.7	○	1mm	207146
SBPR 2006R005-D4	1.8	6.0	0.30	0.05	D4	40	3.7	○	2mm	207147
SBPR 2006R005-D4	1.8	6.0	0.30	0.05	D4	40	3.7	○	2mm	207148
SBPR 3006R005-D4	2.7	6.0	0.30	0.05	D4	50	3.7	○	3mm	207149
SBPR 3006R005-D4	2.7	6.0	0.30	0.05	D4	50	3.7	○	3mm	207150
SBPR 3006R020-D4	2.7	6.0	0.30	0.10	D4	50	3.7	○	3mm	207151
SBPR 3010R005-D4	2.7	10.0	0.30	0.05	D4	50	3.7	○	3mm	207152
SBPR 3010R005-D4	2.7	10.0	0.30	0.05	D4	50	3.7	○	3mm	207153
SBPR 3010R020-D4	2.7	10.0	0.30	0.20	D4	50	3.7	○	3mm	207154
SBPR 4008R005-D4	3.7	8.0	0.40	0.05	D4	50	3.7	○	4mm	207155
SBPR 4008R005-D4	3.7	8.0	0.40	0.05	D4	50	3.7	○	4mm	207156
SBPR 4008R020-D4	3.7	8.0	0.40	0.20	D4	50	3.7	○	4mm	207157
SBPR 4015R005-D4	3.7	15.0	0.40	0.05	D4	50	3.7	○	4mm	207158
SBPR 4015R005-D4	3.7	15.0	0.40	0.05	D4	50	3.7	○	4mm	207159
SBPR 4015R020-D4	3.7	15.0	0.40	0.20	D4	50	3.7	○	4mm	207160
SBPR 5020R005-D5	4.7	20.0	0.50	0.05	D5	50	4.7	○	5mm	207161
SBPR 5020R005-D5	4.7	20.0	0.50	0.05	D5	50	4.7	○	5mm	207162
SBPR 5020R020-D5	4.7	20.0	0.50	0.20	D5	50	4.7	○	5mm	207163
SBPR 6020R005-D6	5.7	20.0	0.50	0.05	D6	50	5.7	○	6mm	207164
SBPR 6020R005-D6	5.7	20.0	0.50	0.05	D6	50	5.7	○	6mm	207165
SBPR 6020R020-D6	5.7	20.0	0.50	0.20	D6	50	5.7	○	6mm	207166
SBPR 7025R015-D7	6.5	25.0	0.50	0.15	D7	50	6.7	○	7mm	207167
SBPR 8030R015-D8	7.5	30.0	0.50	0.15	D8	60	7.7	○	8mm	207168
SBPR 8030R035-D8	7.5	30.0	0.50	0.30	D8	60	7.7	○	8mm	207169

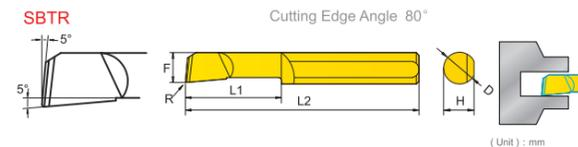

Model	F	L1	S	R	D	L2	H	Stock	Processing Diameter	Order No.
SBTR 1004R005-D4	0.85	4.0	0.15	0.00	D4	40	3.7	○	1mm	207170
SBTR 1004R005-D4	0.85	4.0	0.15	0.00	D4	40	3.7	○	1mm	207171
SBTR 2006R005-D4	1.8	6.0	0.30	0.05	D4	40	3.7	○	2mm	207172
SBTR 2006R005-D4	1.8	6.0	0.30	0.05	D4	40	3.7	○	2mm	207173
SBTR 3006R005-D4	2.7	6.0	0.30	0.05	D4	50	3.7	○	3mm	207174
SBTR 3006R010-D4	2.7	6.0	0.30	0.10	D4	50	3.7	○	3mm	207175
SBTR 3006R020-D4	2.7	6.0	0.30	0.20	D4	50	3.7	○	3mm	207176
SBTR 3010R005-D4	2.7	10.0	0.30	0.05	D4	50	3.7	○	3mm	207177
SBTR 3010R005-D4	2.7	10.0	0.30	0.05	D4	50	3.7	○	3mm	207178
SBTR 3010R010-D4	2.7	10.0	0.30	0.10	D4	50	3.7	○	3mm	207179
SBTR 3010R020-D4	2.7	10.0	0.30	0.20	D4	50	3.7	○	3mm	207180
SBTR 4008R005-D4	3.7	8.0	0.40	0.05	D4	50	3.7	○	4mm	207181
SBTR 4008R005-D4	3.7	8.0	0.40	0.05	D4	50	3.7	○	4mm	207182
SBTR 4008R020-D4	3.7	8.0	0.40	0.20	D4	50	3.7	○	4mm	207183
SBTR 4015R005-D4	3.7	15.0	0.40	0.05	D4	50	3.7	○	4mm	207184
SBTR 4015R005-D4	3.7	15.0	0.40	0.05	D4	50	3.7	○	4mm	207185
SBTR 4015R020-D4	3.7	15.0	0.40	0.20	D4	50	3.7	○	4mm	207186
SBTR 5020R005-D5	4.7	20.0	0.50	0.05	D5	50	4.7	○	5mm	207187
SBTR 5020R005-D5	4.7	20.0	0.50	0.05	D5	50	4.7	○	5mm	207188
SBTR 5020R020-D5	4.7	20.0	0.50	0.20	D5	50	4.7	○	5mm	207189
SBTR 6020R005-D6	5.7	20.0	0.50	0.05	D6	50	5.7	○	6mm	207190
SBTR 6020R005-D6	5.7	20.0	0.50	0.05	D6	50	5.7	○	6mm	207191
SBTR 6020R020-D6	5.7	20.0	0.50	0.20	D6	50	5.7	○	6mm	207192
SBTR 7025R020-D7	6.5	25.0	0.50	0.20	D7	50	6.7	○	7mm	207193
SBTR 8030R020-D8	7.5	30.0	0.50	0.20	D8	60	7.7	○	8mm	207194
SBTR 8030R040-D8	7.5	30.0	0.50	0.40	D8	60	7.7	○	8mm	207194

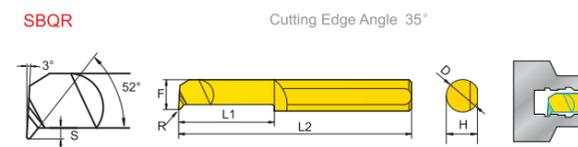

Model	F	L1	S	R	D	L2	H	Stock	Processing Diameter	Order No.
SBQR 3006R005-D4	2.9	6.0	0.6	0.05	D4	50	3.7	○	3mm	207320
SBQR 3010R020-D4	2.9	10.0	0.6	0.20	D4	50	3.7	○	3mm	207321
SBQR 4010R010-D4	3.9	10.0	0.8	0.10	D4	50	3.7	○	4mm	207322
SBQR 4010R020-D4	3.9	10.0	0.8	0.20	D4	50	3.7	○	4mm	207323
SBQR 5015R010-D5	4.9	15.0	1.0	0.10	D5	50	4.7	○	5mm	207324
SBQR 5015R020-D5	4.9	15.0	1.0	0.20	D5	50	4.7	○	5mm	207325
SBQR 6015R010-D6	5.9	15.0	1.0	0.10	D6	50	5.7	○	6mm	207326
SBQR 6015R020-D6	5.9	15.0	1.0	0.20	D6	50	5.7	○	6mm	207327
SBQR 7020R020-D7	6.5	20.0	1.5	0.20	D7	50	6.7	○	7mm	207328
SBQR 8025R010-D8	7.5	25.0	2.0	0.10	D8	60	7.7	○	8mm	207329
SBQR 8025R020-D8	7.5	25.0	2.0	0.20	D8	60	7.7	○	8mm	207330

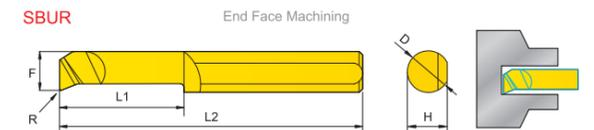

Model	F	L1	S	R	D	L2	H	F1	Stock	Processing Diameter	Order No.
SBUR3010R010-D4	2.7	10.0	0.4	0.1	D4	50	3.7	1.3	○	3mm	207332
SBUR4015R010-D4	3.7	15.0	0.5	0.1	D4	50	3.7	1.7	○	4mm	207333
SBUR5020R020-D5	4.7	20.0	0.7	0.2	D5	50	4.7	2.1	○	5mm	207334
SBUR6020R020-D6	5.7	20.0	1.0	0.2	D6	50	5.7	2.8	○	6mm	207335
SBUR7025R020-D7	6.7	25.0	1.0	0.2	D7	50	6.7	3.2	○	7mm	207336
SBUR8030R020-D8	7.7	30.0	1.0	0.2	D8	60	7.7	3.8	○	8mm	207337

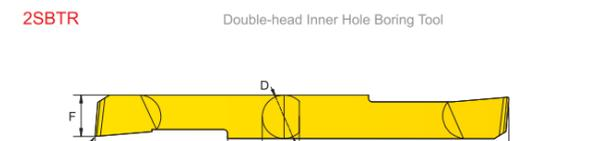

Model	F	L1	S	R	D	L2	H	Stock	Processing Diameter	Order No.
2SBTR02050R005-D3	1.8	5.0	0.15	0.05	D3	50	2.7	○	2mm	207191
2SBTR03150R010-D3	2.7	15.0	0.3	0.1	D3	50	3.7	○	3mm	207192
2SBTR04150R015-D4	3.7	15.0	0.4	0.15	D4	50	3.7	○	4mm	207193
2SBTR05250R010-D5	4.7	25.0	0.5	0.1	D5	70	4.7	○	5mm	207194
2SBTR05250R020-D5	4.7	25.0	0.5	0.2	D5	70	4.7	○	5mm	207495
2SBTR06250R010-D6	5.7	25.0	0.5	0.1	D6	70	5.7	○	6mm	207496
2SBTR06250R020-D6	5.7	25.0	0.5	0.2	D6	70	5.7	○	6mm	207497

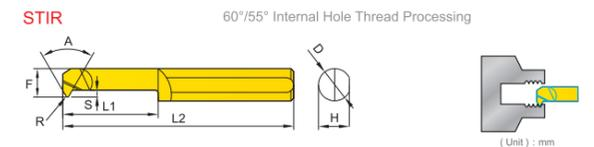

Model	F	L1	S	R	D	L2	American	Metric	Processing Diameter	A	Order No.		
STIR 14050-60°	1.4	5.0	0.4	0.00	D4	50	UN-1, UN-2	M2	0.25	0.45	1.5mm	60°	207421
STIR 18070-60°	1.8	7.0	0.6	0.00	D4	50	UN-3, UN-4	M2.5	0.25	0.7	1.5mm	60°	207422
STIR 24070-60°	2.4	7.0	0.5	0.00	D4	50	UN-3, UN-4	M3	0.35	0.6	2.5mm	60°	207423
STIR 30120-60°	3.0	10.0	0.85	0.00	D4	50	UN-3, UN-4	M4	0.5	0.8	3.1mm	60°	207424
STIR 40150-60°	3.85	15.0	1.1	0.05	D4	50	UN-12, UN-14	M5/M6	0.5	1.0	4.0mm	60°	207425
STIR 50150-60°	4.8	15.0	1.5	0.05	D6	50	UN-14, UN-16	M6	0.75	1.5	5.0mm	60°	207426
STIR 60200-60°	5.8	20.0	1.8	0.08	D6	50	UN-14, G1/16	M10	0.75	1.75	6.0mm	60°	207427
STIR 80220-60°	7.8	22.0	2.2	0.08	D8	50	UN-15, G1/8	M12	1.0	2.0	8.0mm	60°	207428

55° Profile Angle Inch Thread

Model	F	L1	S	R	D	L2	American	Metric	Processing Diameter	A	Order No.	
STIR 40150-55°	3.85	15.0	1.1	0.05	D4	50	1/4-20BSW			4.0mm	55°	207430
STIR 50150-55°	4.8	15.0	1.5	0.05	D6							

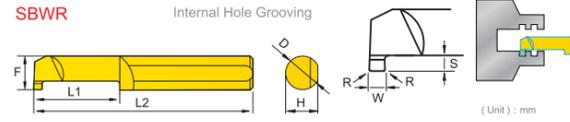

Model	W	S	L1	R	F	D	L2	H	Stock	Processing Diameter	Order No.
SBWR05100R005-D4	0.5	1.0	10	0.05	3.8	D4	50	3.7	○	4mm	207241
SBWR08100R005-D4	0.8	1.0	10	0.05	3.8	D4	50	3.7	○	4mm	207242
SBWR10100R005-D4	1.0	1.5	10	0.05	3.8	D4	50	3.7	○	4mm	207243
SBWR15100R005-D4	1.5	1.5	10	0.05	3.8	D4	50	3.7	○	4mm	207244
SBWR10100R10-D5	1.0	1.5	10	0.1	4.8	D5	50	4.7	○	5mm	207245
SBWR12100R10-D5	1.2	1.5	10	0.1	4.8	D5	50	4.7	○	5mm	207246
SBWR15100R10-D5	1.5	2.0	10	0.1	4.8	D5	50	4.7	○	5mm	207247
SBWR20100R10-D5	2.0	2.0	10	0.1	4.8	D5	50	4.7	○	5mm	207248
SBWR10120R15-D6	1.0	2.0	12	0.15	5.8	D6	50	5.7	○	6mm	207249
SBWR15120R15-D6	1.5	2.0	12	0.15	5.8	D6	50	5.7	○	6mm	207250
SBWR20120R15-D6	2.0	2.0	12	0.15	5.8	D6	50	5.7	○	6mm	207251
SBWR25160R15-D6	2.5	2.5	16	0.15	5.8	D6	50	5.7	○	6mm	207252
SBWR15160R15-D8	1.5	2.0	16	0.15	7.8	D8	50	7.7	○	8mm	207253
SBWR20160R15-D8	2.0	3.0	16	0.15	7.8	D8	50	7.7	○	8mm	207254
SBWR25160R15-D8	2.5	3.0	16	0.15	7.8	D8	50	7.7	○	8mm	207255

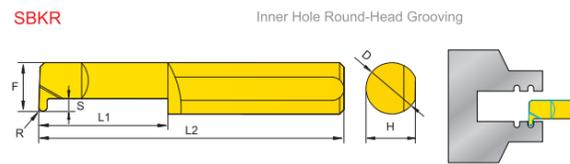

Model	F	S	L1	R	D	L2	H	Stock	Processing Diameter	Order No.
SBKR40100R050-D4	3.8	1.0	10	0.5	D4	50	3.7	○	4mm	207261
SBKR40100R075-D4	3.8	1.0	10	0.75	D4	50	3.7	○	4mm	207262
SBKR60150R050-D6	5.8	1.5	15	0.5	D6	50	5.7	○	6mm	207263
SBKR60150R075-D6	5.8	1.5	15	0.75	D6	50	5.7	○	6mm	207264
SBKR80150R100-D6	5.8	1.5	15	1.0	D6	50	5.7	○	6mm	207265

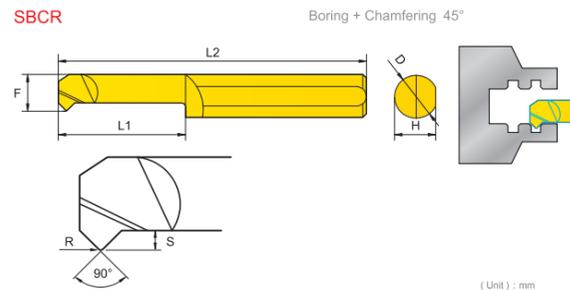

Model	F	L1	S	R	D	L2	H	Stock	Order No.
SBCR30100R020-D4	2.6	10	0.5	0.2	D4	50	3.7	○	207321
SBCR40150R020-D4	3.7	15	0.8	0.2	D4	50	3.7	○	207322
SBCR50150R020-D5	4.7	15	1.2	0.2	D5	50	4.7	○	207323
SBCR60150R020-D6	5.7	15	1.5	0.2	D6	50	5.7	○	207324

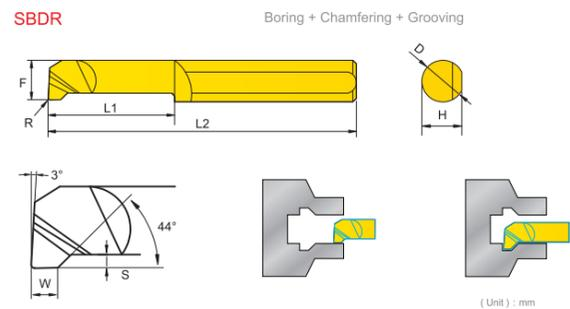

Model	F	L1	S	R	D	L2	H	W	Stock	Processing Diameter	Order No.
SBDP40100R020-D4	3.8	10.0	0.8	0.2	D4	50	3.7	1.5	○	4mm	207331
SBDP50150R020-D5	4.8	15.0	1.2	0.2	D5	50	4.7	1.5	○	5mm	207332
SBDP60150R020-D6	5.8	15.0	1.4	0.2	D6	50	5.7	1.5	○	6mm	207333

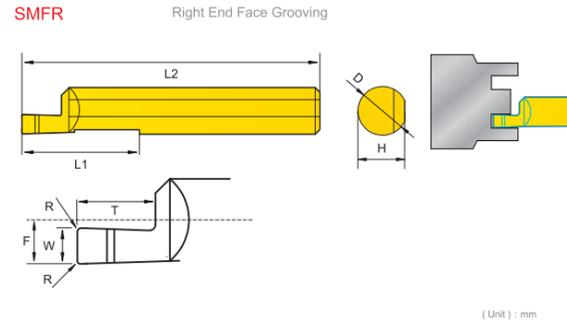

Model	F	L1	T	W	R	D	L2	H	Stock	Processing Diameter	Order No.
SMFR60150W0.75-D6	2.95	15	1.5	0.75	0.1	D6	50	5.7	○	8.0	207271
SMFR60150W1.0-D6	2.95	15	2.0	1.0	0.1	D6	50	5.7	○	8.0	207272
SMFR80200W2.0-D8	3.95	20	4.0	2.0	0.2	D8	50	7.7	○	10.0	207273
SMFR80200W2.5-D8	3.95	20	5.0	2.5	0.2	D8	50	7.7	○	10.0	207274
SMFR80200W3.0-D8	3.95	20	6.0	3.0	0.2	D8	50	7.7	○	10.0	207275

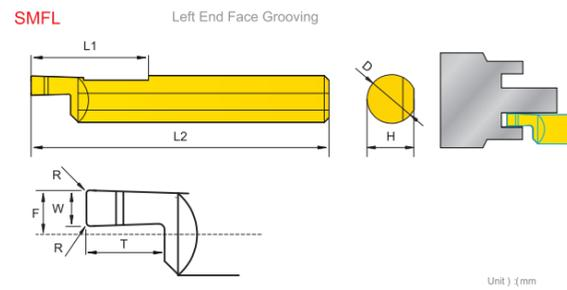

Model	F	L1	T	W	R	D	L2	H	Stock	Processing Diameter	Order No.
SMFL60150W0.75-D6	2.95	15	1.5	0.75	0.1	D6	50	5.7	○	8.0	207281
SMFL60150W1.0-D6	2.95	15	2.0	1.0	0.1	D6	50	5.7	○	8.0	207282
SMFL80200W2.0-D8	3.95	20	4.0	2.0	0.2	D8	50	7.7	○	8.0	207283
SMFL80200W2.5-D8	3.95	20	5.0	2.5	0.2	D8	50	7.7	○	10.0	207284
SMFL80200W3.0-D8	3.95	20	6.0	3.0	0.2	D8	50	7.7	○	10.0	207285

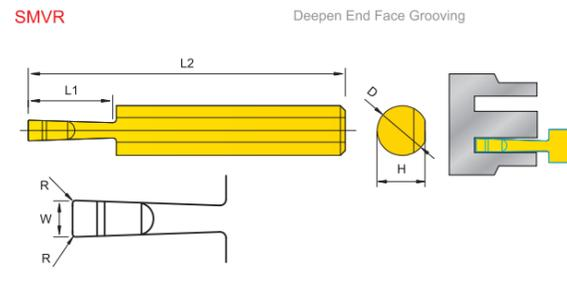

Model	L1	W	R	D	L2	H	Stock	Processing Diameter	Order No.
SMVR10150W2.0-D10	15	2.0	0.2	D10	50	9	○	15	207291
SMVR10150W3.0-D10	15	3.0	0.2	D10	50	9	○	15	207292
SMVR10150W4.0-D10	15	4.0	0.2	D10	50	9	○	15	207293

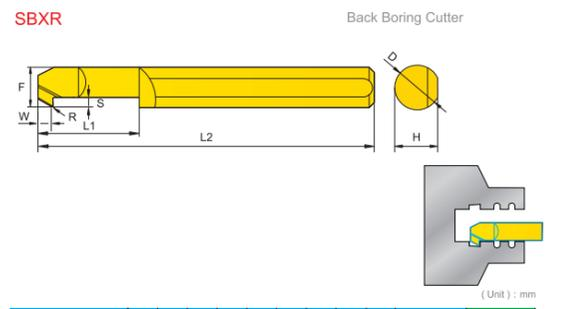

Model	F	W	S	L1	R	D	L2	H	Stock	Processing Diameter	Order No.
SBXR40100R010-D4	3.8	1.5	1.0	10	0.1	D4	50	3.7	○	4mm	207335
SBXR50150R015-D5	4.8	2.0	1.5	15	0.15	D5	50	4.7	○	5mm	207336
SBXR60200R020-D6	5.8	2.0	2.0	20	0.2	D6	50	5.7	○	6mm	207337

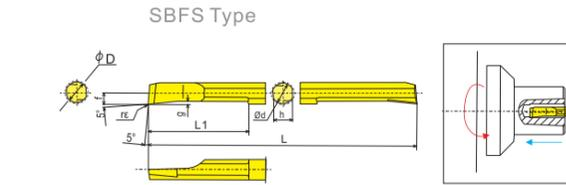

Ordering code	(mm)	Dimensions								Stock	Order Number
		φd	L	L1	f	h	g	r			
SBFS 020R005S	2.2	2	50	10	0.9	1.8	0.25	0.05	○	207100	
030R005S	3.2	3	50	15	1.4	2.7	0.40	0.05	○	207102	
040R005S	4.2	4	60	20	1.9	3.6	0.45	0.05	○	207106	
040R015S	4.2	4	60	20	1.9	3.6	0.45	0.15	○	207108	
050R005S	5.2	5	70	25	2.4	4.5	0.50	0.05	○	207110	
050R015S	5.2	5	70	25	2.4	4.5	0.50	0.15	○	207112	

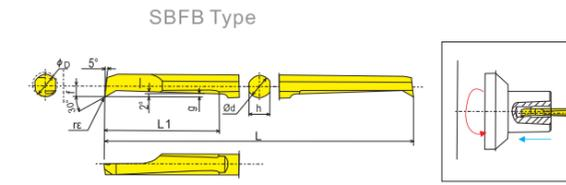

Ordering code	(mm)	Dimensions								Stock	Order Number
		φd	L	L1	f	h	g	r			
SBFB 020R005F	2.2	2	50	10	0.9	1.8	0.25	0.05	○	207300	
030R005F	3.2	3	50	15	1.4	2.7	0.40	0.05	○	207302	
030R015F	3.2	3	50	15	1.4	2.7	0.40	0.15	○	207304	
040R005F	4.2	4	60	20	1.9	3.6	0.45	0.05	○	207306	
040R015F	4.2	4	60	20	1.9	3.6	0.45	0.15	○	207308	
050R005F	5.2	5	70	25	2.4	4.5	0.50	0.05	○	207310	
050R015F	5.2	5	70	25	2.4	4.5	0.50	0.15	○	207312	

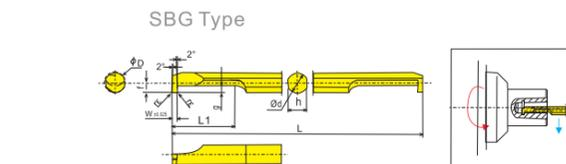

Ordering code	(mm)	Dimensions								Stock	Order Number
		W	φd	L1	g	L	f	h	r		
SBG 030050RB	0.50									○	207200
030075RB	3	0.75	3	9	0.8	50	1.3	2.7	0.05	○	207202
030100RB	1.00									○	207204
040050RB	0.50									○	207206
040075RB	4	0.75	4	12	1.0	60	1.8	3.6	0.05	○	207208
040100RB	1.00									○	207210
050050RB	0.50									○	207212
050100RB	5	1.00	5	20	1.2	70	2.3	4.5	0.05	○	207214
050150RB	1.50									○	207216

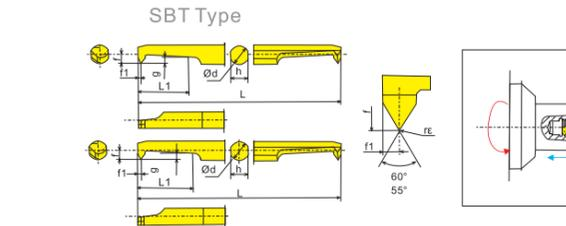

Ordering code	(mm)	Dimensions												Order Number	
		φd	L1	g	L	f	h	r	M4	M5	M6	M8			
SBT 030M4RB	3.0	3.0	7.5	0.8	50	1.3	0.5	2.7	0.05	M4	1/4-11UNC	3/8-16UNC	M4X0.7	M6-32UNC	207400
035M5RB	3.5	3.5	8.5	1.0	60	1.5	0.5	3.2	0.05	M5	1/4-12UNC	3/8-16UNC	M5X0.8	M6-32UNC	207402
040M6RB	4.0	4.0	10.5	1.2	60	1.8	0.7	3.6	0.05	M6	1/2-13UNC	3/4-16UNC	M6X1.0	1/4-20UNC	207404
050M8RB	5.0	5.0	15.4	1.5	70	2.3	0.8	4.5	0.05	M8	3/4-16UNC	1-18UNC	M8X1.25	5/8-18UNC	207406

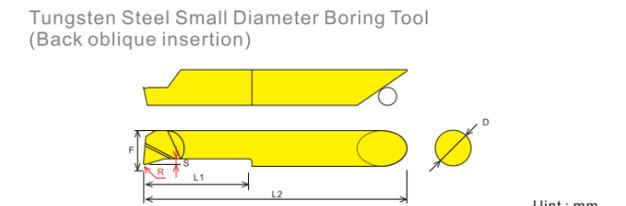

Ordering code	Minimum Machining Diameter	Dimensions							Order Number
		F	L1	S	R	H	L2	φD	
XSBFR 20R005	2.0	1.7	7	0.25	0.05		32.5	4	207120
25R005	2.5	2.3	8	0.25	0.05		33.5	4	207121
30R008	3.0	2.75	12	0.4	0.08		37.5	4	207122
35R010	3.5	3.25	15	0.4	0.1		40	4	207123
40R010	4.0	3.8	15	0.6	0.1		39.5	4	207124
50R015	5.0	4.7	25	0.75	0.15		51	5	207125
60R015	6.0	5.7	30	0.75	0.15		56.5	6	207126
70R015	7.0	6.7	35	0.8	0.15		60	7	207127

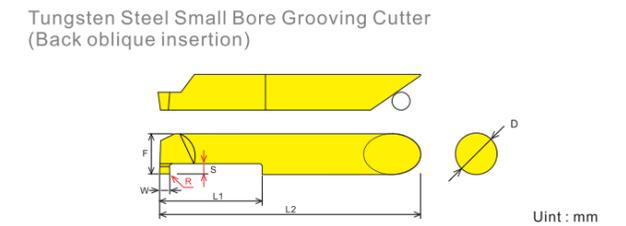

Ordering code	Minimum Machining Diameter	Dimensions								Order Number
		F	L1	S	R	H	L2	φD	W	
XSBWR 0512R005D4	4.0	3.8	12	1.0	0.05		37	4	0.5	207220
1012R005D4	4.0	3.8	12	1.0	0.05		37	4	1.0	207221
1512R005D4	4.0	3.8	12	1.0	0.05		37	4	1.5	207222
1020R010D5	5.0	4.6	20	1.5	0.1		46	5	1.0	207223
1520R010D5	5.0	4.6	20	1.5	0.1		46	5	1.5	207224
2020R010D5	5.0	4.6	20	1.5	0.1		46	5	2.0	207225
1020R015D6	6.0	5.7	20	2.0	0.15		46.5	6	1.0	207226
1520R015D6	6.0	5.7	20	2.0	0.15		46.5	6	1.5	207227
2020R015D6	6.0	5.7	20	2.0	0.15		46.5	6	2.0	207228
1025R015D8	8.0	7.5	25	2.0	0.15		53.5	8	1.0	207229
1525R015D8	8.0	7.5	25	2.0	0.15		53.5	8	1.5	

Modular High Hardness And High Rigidity Shank

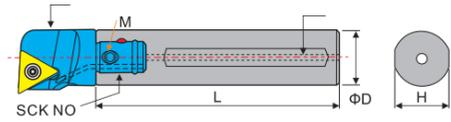

Ordering code	SCK No	Dimensions	Screw	Wrench	Stock	Order Number
		ØD L				
SCK1-Y20-180L	SCK1	20 180	M5	PL25	●	221100
SCK2-Y25-175L	SCK2	25 175	M6	L3	●	221102
SCK2-Y25-225L	SCK2	25 225	M6	L3	●	221104
SCK3-Y32-220L	SCK3	32 220	M6	L3	○	221106
SCK3-Y32-270L	SCK3	32 270	M6	L3	○	221108
SCK4-Y40-267L	SCK4	40 267	M8	L4	○	221110
SCK5-Y50-300L	SCK5	50 300	M10	L5	○	221112

STUP Modular Vehicle Head

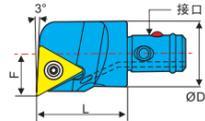

Ordering code	INSERT	Dimensions	Screw	Wrench	Stock	Order Number
		Min. ØD L F				
SCK1-A20-STUPR11-22	TP1103	22 20 22 11.5	M3×8	T9	●	221200
SCK2-A25-STUPR11-30		30 25 25 15			●	221202
SCK1-A20-STUPR1603-25		25 20 22 13			●	221204
SCK2-A25-STUPR1603-28		28 25 27 14			●	221206
SCK3-A32-STUPR1603-38		38 32 30 7.5			○	221208
SCK4-A40-STUPR1603-50	TP1603	50 40 33 21.5	M4×8	T15	○	221210
SCK5-A50-STUPR1603-60		60 50 35 26.5			○	221212
SCK1-A20-STUPR16T3-25		25 20 22 13			●	221214
SCK2-A25-STUPR16T3-28		28 25 27 14			●	221216
SCK3-A32-STUPR16T3-38		38 32 30 17.5			○	221218
SCK4-A40-STUPR16T3-50	TP16T3	50 40 33 21.5	M4×8	T15	○	221220
SCK5-A50-STUPR16T3-60		60 50 35 26.5			○	221222
SCK1-A20-STUPR1604-25		25 20 22 13			●	221224
SCK2-A25-STUPR1604-28		28 25 27 14			●	221226
SCK3-A32-STUPR1604-38		38 32 30 17.5			○	221228
SCK4-A40-STUPR1604-50	TP1604	50 40 33 21.5	M4×8	T15	○	221230
SCK5-A50-STUPR1604-60		60 50 35 26.5			○	221232

STUC Modular Vehicle Head

Ordering code	INSERT	Dimensions	Screw	Wrench	Stock	Order Number
		Min. ØD L F				
SCK1-A20-STUCR11-22	TC1103	22 20 22 11	M2.5×6	T8	●	221600
SCK2-A25-STUCR11-28		28 25 25 14			●	221602
SCK1-A20-STUCR16-22		22 20 22 11			●	221604
SCK2-A25-STUCR16-28		28 25 27 14			●	221606
SCK3-A32-STUCR16-38		38 32 30 17.5			○	221608
SCK4-A40-STUCR16-50	TC16T3	50 40 33 21.5	M4×8	T15	○	221610
SCK5-A50-STUCR16-60		60 50 35 26.5			○	221612

SCLC modular vehicle head

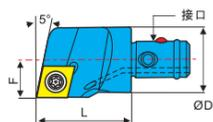

Ordering code	INSERT	Dimensions	Screw	Wrench	Stock	Order Number
		Min. ØD L F				
SCK1-A20-SCLCR09-22		22 20 22 11			●	221300
SCK2-A25-SCLCR09-28		28 25 25 14.5			●	221302
SCK3-A32-SCLCR09-38	CC09T3	38 32 30 17.5	M4×8	T15	●	221304
SCK4-A40-SCLCR09-50		50 40 33 21			●	221306
SCK5-A50-SCLCR09-60		60 50 35 30			○	221308

SCKC Modular Vehicle Head

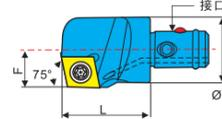

Ordering code	INSERT	Dimensions	Screw	Wrench	Stock	Order Number
		Min. ØD L F				
SCK1-A20-SCKCR09-22	CC09T3	22 20 22 11	M4×8	T15	●	221800
SCK2-A25-SCKCR09-30		30 25 25 15			○	221802
SCK3-A32-SCKCR09-38		38 32 30 17.5			○	221804

Modular Tungsten Steel Tool Holder

Ordering code	SCK No	Dimensions	Screw	Wrench	Stock	Order Number
		ØD L				
SCK1-E20-180L	SCK1	20 180	M5	PL25	●	221500
SCK1-E20-230L	SCK1	20 230	M5	PL25	●	221502
SCK2-E25-175L	SCK2	25 175	M6	L3	●	221504
SCK2-E25-225L	SCK2	25 225	M6	L3	●	221506
SCK3-E32-170L	SCK3	32 170	M6	L3	○	221508
SCK3-E32-220L	SCK3	32 220	M6	L3	○	221510
SCK3-E32-270L	SCK3	32 270	M6	L3	○	221512
SCK4-E40-267L	SCK4	40 267	M8	L4	○	221514
SCK5-E50-300L	SCK5	50 300	M10	L5	○	221516

SVJC Modular Cutter Head

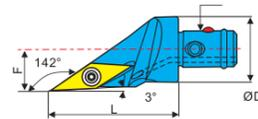

Ordering code	INSERT	Dimensions	Screw	Wrench	Stock	Order Number
		Min. ØD L F				
SCK1-A20-SVJCR11-22	VC1103	22 20 19 11	M2.5×6	T8	●	221900
SCK1-A20-SVJCR16-22		22 20 33 11			●	221902
SCK2-A25-SVJCR16-28	VC1604	28 25 35 14	M3.5×6	T15	●	221904
SCK3-A32-SVJCR16-35		35 32 39 17.5			●	221906

SVUC Modular Cutter Head

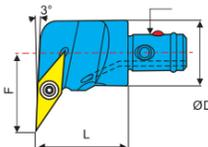

Ordering code	INSERT	Dimensions	Screw	Wrench	Stock	Order Number
		Min. ØD L F				
SCK1-A20-SVUCR11-27	VC1103	27 20 22 15	M2.5×6	T8	●	222300
SCK2-A25-SVUCR11-30		30 25 25 17			●	222302
SCK1-A20-SVUCR16-31		31 20 27 19			●	222304
SCK2-A25-SVUCR16-33		33 25 27 18			●	222306
SCK3-A32-SVUCR16-40	VC1604	40 32 30 22	M3.5×8	T15	○	222308
SCK4-A40-SVUCR16-50		50 40 33 27			○	222310

SDQC Modular Car Cutter Head

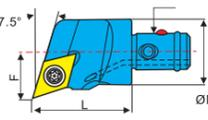

Ordering code	INSERT	Dimensions	Screw	Wrench	Stock	Order Number
		Min. ØD L F				
SCK1-A20-SDQCR11-25		25 20 22 13			●	222000
SCK2-A25-SDQCR11-32		32 25 27 17			●	222002
SCK3-A32-SDQCR11-40	DC11T3	40 32 30 20	M4×8	T15	●	222004
SCK4-A40-SDQCR11-50		50 40 33 25			○	222006
SCK5-A50-SDQCR11-60		60 50 35 30			○	222008

SDUC Modular Car Cutter Head

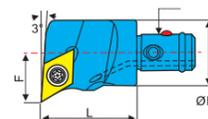

Ordering code	INSERT	Dimensions	Screw	Wrench	Stock	Order Number
		Min. ØD L F				
SCK1-A20-SDUCR11-23		23 20 22 12.8			●	222400
SCK1-A20-SDUCR11-25		25 20 22 13			●	222402
SCK2-A25-SDUCR11-32		32 25 25 17			●	222404
SCK3-A32-SDUCR11-40	DC11T3	40 32 30 20	M4×8	T15	●	222406
SCK4-A40-SDUCR11-50		50 40 33 25			○	222408
SCK5-A50-SDUCR11-60		60 50 35 30			○	222410

SDZC Modular Car Cutter Head

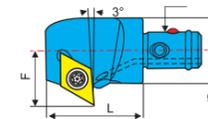

Ordering code	INSERT	Dimensions	Screw	Wrench	Stock	Order Number
		Min. ØD L F				
SCK1-A20-SDZCR11-26	DC11T3	26 20 29 15.5	M4×8	T15	●	222100
SCK2-A25-SDZCR11-33		33 25 34 18			●	222102
SCK3-A32-SDZCR11-40		40 32 35 21.5			○	222104

MGIV Modularized Cutter Head

Ordering code	INSERT	Dimensions	Screw	Wrench	Stock	Order Number
		Min. ØD L F				
SCK1-A20-MGIVR25-2	MGMN2	25 20 24 14.1			○	222200
SCK1-A20-MGIVR25-3		3 25 20 24 14.1			○	222202
SCK1-A20-MGIVR25-4		4 25 20 24 14.1			○	222204
SCK2-A25-MGIVR30-2	MGMN2	30 25 25 16.6	M5×12	T15	○	222206
SCK2-A25-MGIVR32-3		3 32 25 25 18.6			○	222208
SCK2-A25-MGIVR32-4		4 32 25 25 18.6			○	222210

MTUN

Ordering code	Dimensions	INSERT	Shim	Pin	Clamp	Screw	Wrench	Stock	Order Number
	Min. ØD L F								
SCK1-A20-MTUNR16-25	25 20 29 13							●	222600
SCK2-A25-MTUNR16-32	32 25 30 17	TN1604		CTM511	HL1810	ML0620	PL25 PL30	●	222602
SCK3-A32-MTUNR16-40	40 32 34 20							●	222604
SCK4-A40-MTUNR16-50	50 40 35 26							●	222606
SCK5-A50-MTUNR16-60	60 50 36 31	MT1603	CTM513	HL1813	ML0625	PL25 PL30		○	222608

MCLN

Ordering code	Dimensions	INSERT	Shim	Pin	Clamp	Screw	Wrench	Stock	Order Number
	Min. ØD L F								
SCK1-A20-MCLNR12-25	25 20 33 13							●	222700
SCK2-A25-MCLNR12-32	32 25 34 15							●	222702
SCK3-A32-MCLNR12-40	40 32 35 20	CN1204		CTM511	HL1810	ML0620	PL25 PL30	●	222704
SCK4-A40-MCLNR12-50	50 40 35 25							●	222706
SCK5-A50-MCLNR12-63	63 50 36 30	MC1204	CTM513	HL1813	ML0625	PL25 PL30		○	222708

S..MW..

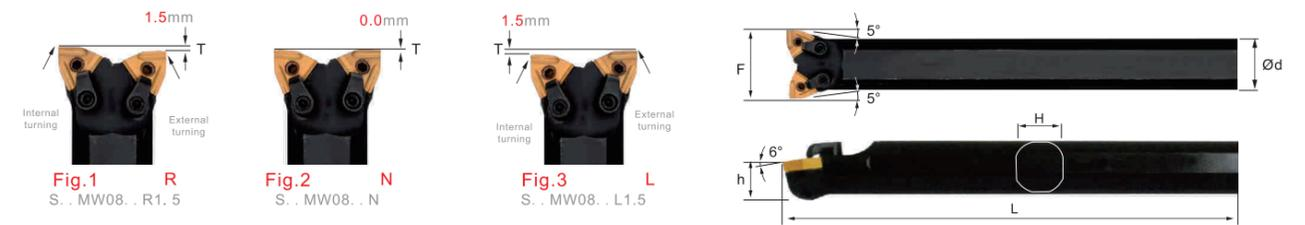

Features: the turning of outer circle and inner hole can be completed with one knife, saving tool changing time and improving machining efficiency!

Ordering code	Dimensions	Insert	Shim	Pin	Clamp	Screw	Wrench	Fig
	ØD _{min} ød L H h F T							
S25R-MW08-R1.5	41 25 200 24 15 33 1.5							Fig.1
S32S-MW08-R1.5	49 32 250 30 20 38 1.5	WN..0804..	MW0804	CTM617	HL1814	ML0625	PL30	
S40S-MW08-R1.5	56 40 250 38 25 45 1.5							
S25R-MW08-N	41 25 200 24 15 33 0							Fig.2
S32S-MW08-N	49 250 30 20 38 0	WN..0804..	MW0804	CTM617	HL1814	ML0625	PL30	
S40S-MW08-N	56 250 38 25 45 0							
S25R-MW08-L1.5	41 25 200 24 15 33 1.5							Fig.3
S32S-MW08-L1.5	49 250 30 20 38 1.5	WN..0804..	MW0804	CTM617	HL1814	ML0625	PL30	
S40S-MW08-L1.5	56 250 38 25 45 1.5							

S..MC..

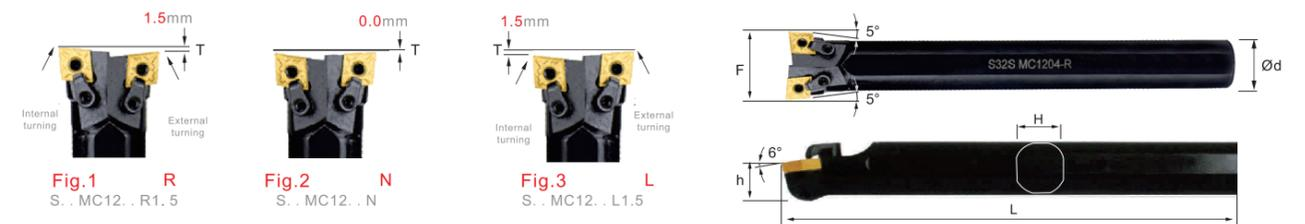

Features: the turning of outer circle and inner hole can be completed with one knife, saving tool changing time and improving machining efficiency!

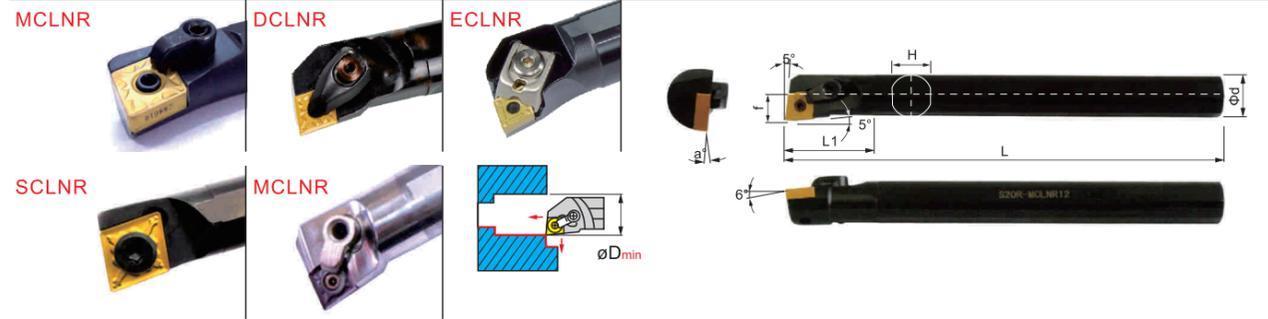

(Inserts): A01-A02 (Toolholder Parts): P01-P04 R-Type

Ordering code	Dimensions							Insert	Shim	Pin	Clamp	Screw	Wrench	Stock		Order Number
	ϕD_{min}	ϕd	L	L1	H	f	α°							R	L	
S16Q-MCLNR/L12	20	16	180	35	15	11	18°	CN..1204..	MC1204	CTM613	HL1810	ML0620	PL25 PL30	●	●	223100
S20R-MCLNR/L12	25	20	200	45	19	13	15°							●	●	223102
S25S-MCLNR/L12	29	25	250	45	25	15	12°							●	●	223104
S32T-MCLNR/L12	38	32	300	50	30	20.5	17°							●	●	223106
S40T-MCLNR/L12	44	40	300	55	38	24	15°							●	●	223108
S50U-MCLNR/L12	60	50	350	55	48	31	12°							●	●	223110
S32T-MCLNR/L16	40	32	300	60	30	22.5	17°	CN..1606..	MC1604	CTM822	HL2217	ML0830	PL30 PL40	●	●	223111
S40T-MCLNR/L16	48	40	300	60	38	26	15°							●	●	223112
S50U-MCLNR/L16	60	50	350	60	48	31	12°							●	●	223114
S60V-MCLNR/L16	70	60	400	60	58	36	10°	●	●	223116						
S40T-MCLNR/L19	50	40	300	70	38	26	15°	CN..1906..	MC1904	CTM1022	HL2217	ML0830	PL30 PL40	○	○	223117
S50U-MCLNR/L19	60	50	350	70	48	31	12°							●	●	223118
S60V-MCLNR/L19	70	60	400	70	58	36	10°							●	●	223120

Ordering code	Dimensions							Insert	Shim	Shim Screw	Clamp	Screw	Wrench	Stock		Order Number
	ϕD_{min}	ϕd	L	L1	H	f	α°							R	L	
S20R-DCLNR/L12	25	20	200	45	19	13	15°	CN..1204..	MC1204	M6X9P	HLD-1	M6X21	PL30	○	○	223130
S25S-DCLNR/L12	29	25	250	45	24	15	12°							○	○	223132
S32T-DCLNR/L12	38	32	300	50	30	20.5	17°							○	○	223134
S40T-DCLNR/L12	44	40	300	55	38	24	15°							○	○	223136

Ordering code	Dimensions							Insert	Shim	Pin	Clamp	Screw	Wrench	Stock		Order Number
	ϕD_{min}	ϕd	L	L1	H	f	α°							R	L	
S32T-ECLNR/L12	40	32	300	50	30	22.5	17°	CN..1204..	MC1204	CT618-Z	HLZ-C	M8X25	PL30 PL40	○	○	223150
S40T-ECLNR/L12	48	40	300	55	38	26	15°							○	○	223152

Ordering code	Dimensions							Insert	Screw	Wrench	Stock		Order Number
	ϕD_{min}	ϕd	f	L	L1	H	α°				R	L	
S16Q-SCLNR/L12	19	16	9.5	180	26	14.8	15°	CN..1204..	M4.5x14W	T20	●	●	227600
S18Q-SCLNR/L12	21	18	10.5	180	28	16.8	15°				●	●	227601
S20R-SCLNR/L12	23	20	11.5	200	28	18.4	15°				●	●	227602

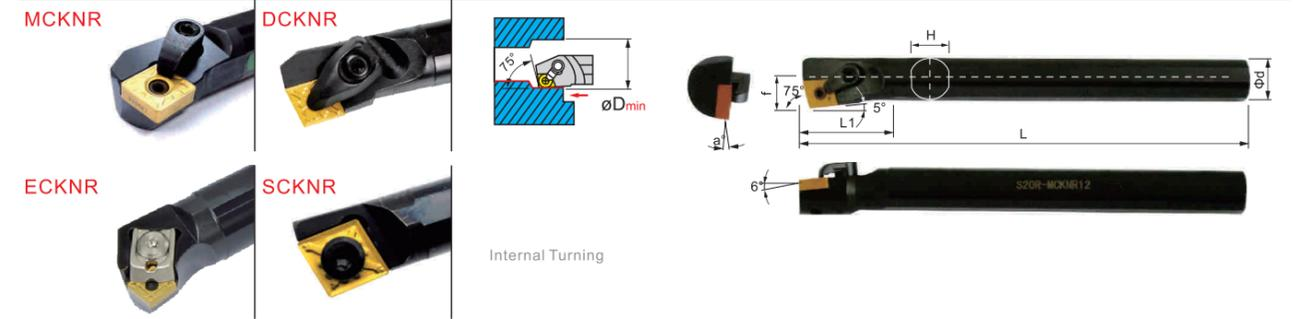

(Inserts): A01-A02 (Toolholder Parts): P01-P04 R-Type

Ordering code	Dimensions							Insert	Shim	Pin	Clamp	Screw	Wrench	Stock		Order Number
	ϕD_{min}	ϕd	L	L1	H	f	α°							R	L	
S20R-MCKNR/L12	25	20	200	45	19	13	15°	CN..1204..	MC1204	CTM613	HL1810	ML0620	PL25 PL30	●	●	223200
S25S-MCKNR/L12	30	25	250	45	24	15.5	12°							●	●	223202
S32T-MCKNR/L12	38	32	300	50	30	20.5	17°							●	●	223204
S40T-MCKNR/L12	46	40	300	55	38	24	15°							●	●	223206
S50U-MCKNR/L12	60	50	350	70	48	35	12°							●	●	223208

Ordering code	Dimensions							Insert	Shim	Shim Screw	Clamp	Screw	Wrench	Stock		Order Number
	ϕD_{min}	ϕd	L	L1	H	f	α°							R	L	
S20R-DCKNR/L12	25	20	200	45	19	13	15°	CN..1204..	MC1204	M6X9P	HLD-1	M6X21	PL30	○	○	223230
S25S-DCKNR/L12	30	25	250	45	24	15.5	12°							○	○	223232
S32T-DCKNR/L12	38	32	300	50	30	20.5	17°							○	○	223234
S40T-DCKNR/L12	46	40	300	55	38	24	15°							○	○	223236

Ordering code	Dimensions							Insert	Shim	Pin	Clamp	Screw	Wrench	Stock		Order Number
	ϕD_{min}	ϕd	L	L1	H	f	α°							R	L	
S32T-ECKNR/L12	38	32	300	50	30	20.5	17°	CN..1204..	MC1204	CT618-Z	HLZ-CB	M8X25	PL30 PL40	○	○	223250
S40T-ECKNR/L12	46	40	300	55	38	24	15°							○	○	223252

Ordering code	Dimensions							Insert	Screw	Wrench	Stock		Order Number
	ϕD_{min}	ϕd	f	L	L1	H	α°				R	L	
S16Q-SCKNR/L12	19	16	9.5	180	26	14.8	15°	CN..1204..	M4.5x14W	T20	●	●	227610
S18Q-SCKNR/L12	20	18	10.5	180	28	16.8	15°				●	●	227611
S20R-SCKNR/L12	23	20	11.5	200	28	18.4	15°				●	●	227612

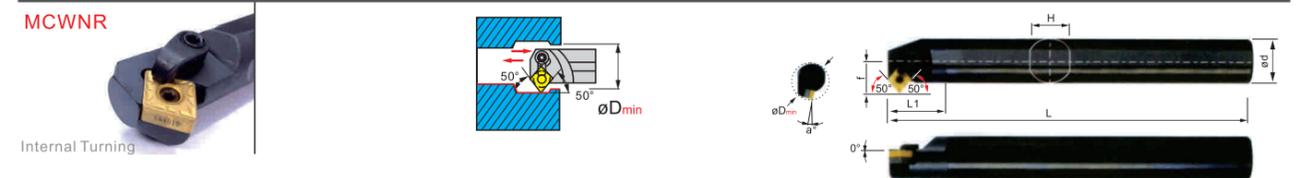

(Inserts): A01-A02 (Toolholder Parts): P01-P04 R-Type

Ordering code	Dimensions							Insert	Shim	Pin	Clamp	Screw	Wrench	Stock		Order Number
	ϕD_{min}	ϕd	L	L1	H	f	α°							R	L	
S20R-MCWNR/L12	30	20	200	45	19	17	15°	CN..1204..	MC1204	CTM613	HL1810	ML0620	PL25 PL30	●	●	223300
S25S-MCWNR/L12	35	25	250	45	24	19.5	12°							●	●	223302
S32T-MCWNR/L12	42	32	300	50	30	23.5	17°							●	●	223304
S40T-MCWNR/L12	50	40	300	55	38	27	15°							●	●	223306

Ordering code	Dimensions							Insert	Shim	Shim Screw	Clamp	Screw	Wrench	Stock		Order Number
	ϕD_{min}	ϕd	L	L1	H	f	α°							R	L	
S20R-DCWNR/L12	30	20	200	45	19	17	15°	CN..1204..	MC1204	M6X9P	HLD-1	M6X21	PL30	○	○	223330
S25S-DCWNR/L12	35	25	250	45	24	19.5	12°							○	○	223332
S32T-DCWNR/L12	42	32	300	50	30	23.5	17°							○	○	223334
S40T-DCWNR/L12	50	40	300	55	38	27	15°							○	○	223336

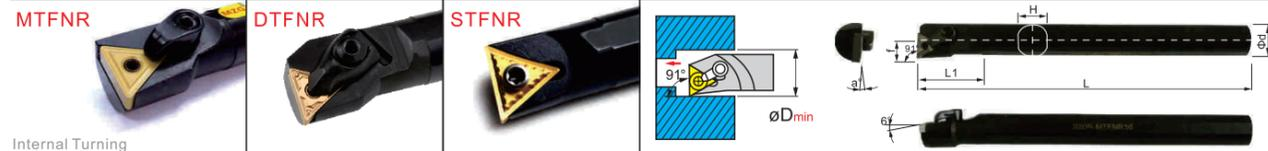

(Inserts): A09-A10 (Toolholder Parts): P01-P04 R-Type

Ordering code	Dimensions							Insert	Shim	Pin	Clamp	Screw	Wrench	Stock		Order Number
	ϕD_{min}	ϕd	L	L1	H	f	α°							R	L	
S16Q-MTFNR/L16	20	16	180	35	15	11	18°	TN..1604..	CTM511	HL1810	ML0620	PL25 PL30	●	●	223500	
S18Q-MTFNR/L16	22	18	180	35	17	12	15°								223501	
S20R-MTFNR/L16	25	20	200	40	19	13	15°								223502	
S25S-MTFNR/L16	30	25	250	45	24	15.5	12°								223504	
S32T-MTFNR/L16	38	32	300	54	30	20.5	17°								223506	
S40T-MTFNR/L16	47	40	300	60	38	25	15°								223508	

Ordering code	Dimensions							Insert	Shim	Shim Screw	Clamp	Screw	Wrench	Stock		Order Number
	ϕD_{min}	ϕd	L	L1	H	f	α°							R	L	
S16Q-DTFNR/L16	20	16	180	35	15	11	18°	TN..1604..	MT1603	M5X9P	HLD-3	M6X21	PL30	○	○	223520
S18Q-DTFNR/L16	22	18	180	35	17	12	15°									223521
S20R-DTFNR/L16	25	20	200	40	19	13	15°									223522
S25S-DTFNR/L16	30	25	250	45	24	15.5	12°									223524
S32T-DTFNR/L16	38	32	300	54	30	20.5	17°									223526
S40T-DTFNR/L16	47	40	300	60	38	25	15°									223528

Ordering code	Dimensions							Insert	Screw	Wrench	Stock		Order Number
	ϕD_{min}	ϕd	f	L	L1	H	α°				R	L	
S16Q-STFNR/L16	18	16	9	180	26	14.8	15°	TN..1604..	M3.5x13T	T15	●	●	227710
S18Q-STFNR/L16	21	18	10	180	28	16.8	15°						227711
S20R-STFNR/L16	22	20	11	200	28	18.4	15°						227712

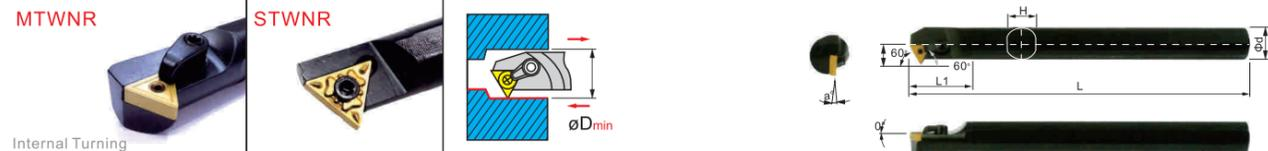

(Inserts): A09-A10 (Toolholder Parts): P01-P04 R-Type

Ordering code	Dimensions							Insert	Shim	Pin	Clamp	Screw	Wrench	Stock		Order Number
	ϕD_{min}	ϕd	L	L1	H	f	α°							R	L	
S20R-MTWNR/L16	27	20	200	40	19	14	15°	TN..1604..	CTM511	HL1810	ML0620	PL25 PL30	●	●	223600	
S25S-MTWNR/L16	32	25	250	45	24	16.5	12°								223602	
S32T-MTWNR/L16	39	32	300	54	30	20	17°								223604	

Ordering code	Dimensions							Insert	Shim	Shim Screw	Clamp	Screw	Wrench	Stock		Order Number
	ϕD_{min}	ϕd	L	L1	H	f	α°							R	L	
S20R-DTWNR/L16	27	20	200	40	19	14	15°	TN..1604..	MT1603	M5X9P	HLD-3	M6X21	PL30	○	○	223610
S25S-DTWNR/L16	32	25	250	45	24	16.5	12°									223612
S32T-DTWNR/L16	39	32	300	54	30	20	17°									223616

Ordering code	Dimensions							Insert	Screw	Wrench	Stock		Order Number
	ϕD_{min}	ϕd	f	L	L1	H	α°				R	L	
S16Q-STWNR/L16	21	16	11.5	180	26	14.8	15°	TN..1604..	M3.5x13T	T15	●	●	227750
S18Q-STWNR/L16	23	18	12.5	180	28	16.8	15°						227751
S20R-STWNR/L16	25	20	13.5	200	28	18.4	15°						227752

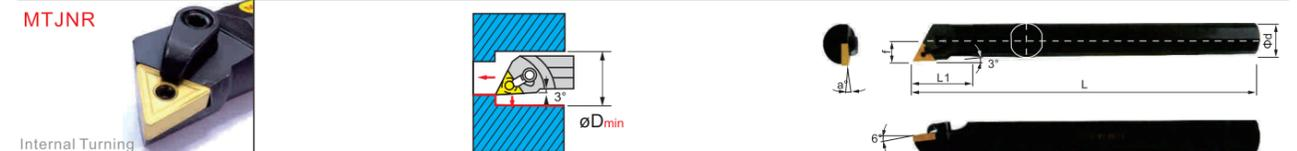

(Inserts): A09-A10 (Toolholder Parts): P01-P04 R-Type

Ordering code	Dimensions							Insert	Shim	Pin	Clamp	Screw	Wrench	Stock		Order Number
	ϕD_{min}	ϕd	L	L1	H	f	α°							R	L	
S20R-MTJNR/L16	25	20	200	40	19	12.5	15°	TN..1604..	MT1603	CTM513	HL1813	ML0625	PL25 PL30	●	●	223400
S25S-MTJNR/L16	32	25	250	45	24	16	12°									223402
S32T-MTJNR/L16	41	32	300	54	30	22.5	17°									223404
S40U-MTJNR/L16	50	40	350	55	38	27	15°									223406

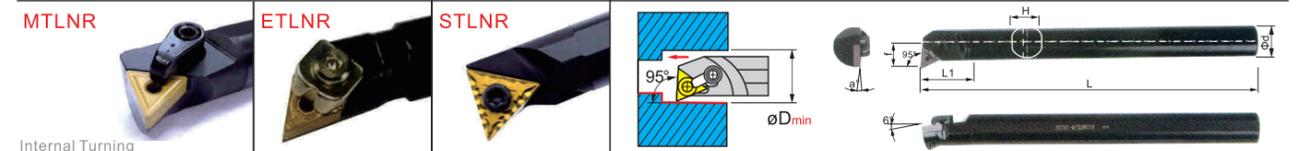

(Inserts): A09-A10 (Toolholder Parts): P01-P04 R-Type

Ordering code	Dimensions							Insert	Shim	Pin	Clamp	Screw	Wrench	Stock		Order Number
	ϕD_{min}	ϕd	L	L1	H	f	α°							R	L	
S18Q-MTLNR/L16	22	18	180	36	17	12.5	15°	TN..1604..	CTM511	HL1810	ML0620	PL20 PL30	●	●	223734	
S20R-MTLNR/L16	25	20	200	37	19	13.5	15°								223736	
S25S-MTLNR/L16	30	25	250	45	23	17	12°								223738	
S32T-MTLNR/L16	40	32	300	50	30	22.5	17°								223740	

Ordering code	Dimensions							Insert	Shim	Pin	Clamp	Screw	Wrench	Stock		Order Number
	ϕD_{min}	ϕd	L	L1	H	f	α°							R	L	
S20R-ETLNR/L16	25	20	200	40	13	13.5	15°	TN..1604..	CT511-Z	HLZ-T	M8X25	PL25 PL40	●	●	223750	
S25S-ETLNR/L16	31	25	250	45	24	17	12°								223752	
S32T-ETLNR/L16	41	32	300	54	30	22.5	12°								223754	
S40T-ETLNR/L16	50	40	300	60	38	26.5	10°								223756	

Ordering code	Dimensions							Insert	Screw	Wrench	Stock		Order Number
	ϕD_{min}	ϕd	f	L	L1	H	α°				R	L	
S16Q-STLNR/L16	21	16	11.5	180	26	14.8	15°	TN..1604..	M3.5x13T	T15	●	●	227730
S18Q-STLNR/L16	23	18	12.5	180	28	16.8	15°						227731
S20R-STLNR/L16	25	20	13.5	200	28	18.4	15°						227732

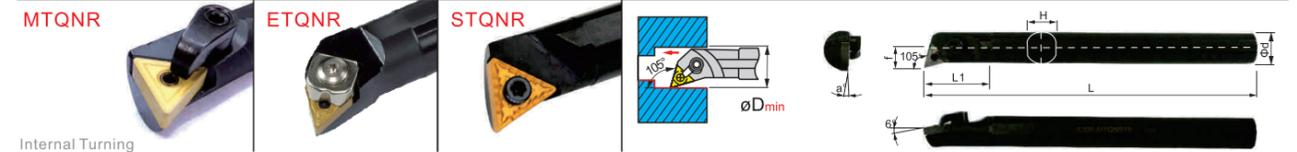

(Inserts): A09-A10 (Toolholder Parts): P01-P04 R-Type

Ordering code	Dimensions							Insert	Shim	Pin	Clamp	Screw	Wrench	Stock		Order Number
	ϕD_{min}	ϕd	L	L1	H	f	α°							R	L	
S20R-MTQNR/L16	25	20	200	40	13	13.5	15°	TN..1604..	CTM511	HL1810	ML0620	PL25 PL30	●	●	223800	
S25S-MTQNR/L16	31	25	250	45	24	17	12°								223802	
S32T-MTQNR/L16	41	32	300	54	30	22.5	17°								223804	
S40T-MTQNR/L16	50	40	300	60	38	26.5	15°								223806	

Ordering code	Dimensions							Insert	Shim	Pin	Clamp	Screw	Wrench	Stock		Order Number
	ϕD_{min}	ϕd	L	L1	H	f	α°							R	L	
S20R-ETQNR/L16	25	20	200	40	13	13.5	15°	TN..1604..	CT511-Z	HLZ-T	M8X25	PL25 PL40	●	●	223810	
S25S-ETQNR/L16	31	25	250	45	24	17	12°								223812	
S32T-ETQNR/L16	41	32	300	54	30	22.5	12°								223814	
S40T-ETQNR/L16	50	40	300	60	38	26.5	10°								223816	

Ordering code	Dimensions							Insert	Screw	Wrench	Stock		Order Number
	ϕD_{min}	ϕd	f	L	L1	H	α°				R	L	
S16Q-STQNR/L16	21	16	11.5	180	26	14.8	15°	TN..1604..	M3.5x13T	T15	●	●	227720
S18Q-STQNR/L16	23	18	12.5	180	28	16.8	15°						227721
S20R-STQNR/L16	25	20	13.5	200	28	18.4	15°						227722