



TABLE OF CONTENTS

Oil Lubrication System-SRL

Resistance Type Oil Lubricators

P. 01~P. 17

Manual Type	CLA, CTA, CKE-----	01
Electric Type		
Controlled by PLC	CEN01, CESC01, CEV-----	04
Controlled by Timer		
- Time Adjustable	CESP/H/D/W, CEN02, CESC02, CENA-----	08
- Interval Time Fixed	CESMA/B, CESC, CESS, CESSB----	15
Pneumatic Type	PNA-----	17

Circulating Type Oil Lubricators

P. 18~P. 28

Electric Type		
Controlled by PLC	CEH, CEU, CLS, CLSA/B, CLSS, CLST-----	18
Controlled by Timer	CEF-----	28

Oil-Mist Type Lubricators P. 29~P. 33

Electric Type		
Controlled by PLC	CEN24, CEN25-----	29
Controlled by Timer	CEN22, CEN23-----	31
Pneumatic Type	COM-----	33

Oil Lubrication System-PDI

Pressure-Relief Type Oil Lubricators

P. 34~P. 44

Manual Type	CLAB-----	34
Electric Type		
Controlled by PLC	CEN03, CESC03, CEVB-----	35
Controlled by Timer	CEPB, CEWB, CEN04, CESC04, CENB-----	39
Pneumatic Type	PNB-----	44

Oil-Air Type Lubricators P. 45~P. 47

Pneumatic Type		
Controlled by PLC	POA, PNC03-----	45
Electric Type		
Controlled by Timer	COA-----	47

Minimum Quantity Oil Lubricators

P. 48~P. 49

Pneumatic Type	POM-----	48
-----------------------	----------	----

Grease Lubrication System-SRL

Resistance Type Grease Lubricators

P. 50~P. 68

Manual Type	CLHA, CLHA-25, CLHP-----	50
Electric Type		
Controlled by PLC	KSC/P, KGA/P, KGC/P, KGH, KGV, KAC/P-----	53
Controlled by Timer	KSB/P, KGN/P, KGNV-----	63
Pneumatic Type	MAG-----	68

Grease Lubrication System-PDI

Pressure-Relief Type Grease Lubricators

P. 69~P. 74

Electric Type		
Controlled by PLC	KGB/P, KAB/P, KGVB-----	69
Controlled by Timer	KGNVB, KGNB/P-----	74

Minimum Quantity Grease Lubricators

P. 77~P. 80

Pneumatic Type	POM-A, POM-AP-----	77
-----------------------	--------------------	----

Distributors, Proportion Adapters, Spray Guns P. 81~P. 100

Open-Straight Type Distributors		
	A, AE, B, CB, AB, BB, BS-----	81
Progressive Feeders		
	CV-----	85
Proportion Adapters		
	CPS, CPB, PTT, CPT, CPV, ST, SS----	87
Oil Meter Adapters	RC, RD, RE, RF-----	88
Volume Distributors		
	CAB, CBB, CCB, CDB, T, CO, OA, OC, CFB-----	89
Spray Guns	OT, OTS, OE, OG, OQ-----	99

Oil Pumps, Motors P. 101~P. 107

Rotary Oil Pumps-----	101
Heavy Oil Pumps-----	102
Motors (PMO-0)-----	103
Motors with Connectors (PMO-2), Adjustable Pressure Valves-----	105
Close-Coupled Motors (PMO-8)-----	106
Eletromagnetic Pumps, Gear Pumps with Motors--	107

Fittings, Accessories P. 108~P. 128

Adapters-----	108
Grease Nipples, Pressure Gauges, Oil Windows--	116
Brushes, Rotary Unions-----	117
Float Switches-----	118
Pressure Switches-----	119
Filters-----	120
Magnetic Sensor Reed Switches-----	122
Pipes-----	123
Pipe Benders, Pipe Clamps, Pipe Clips-----	125

Others P. 129~P. 131

Air Operated Fillers-----	129
Adjustable Automatic Lubricators-----	130

Appendix P. 132~P. 147

Layouts of Lubrication Systems-----	132
Customized Products-----	146
Safety Cautions, Maintenance Instructions, and Warranty Terms-----	147

CLA Resistance Type Oil Manual Lubricator



CLA-6-D-H-1



CLA-8-R-H-1

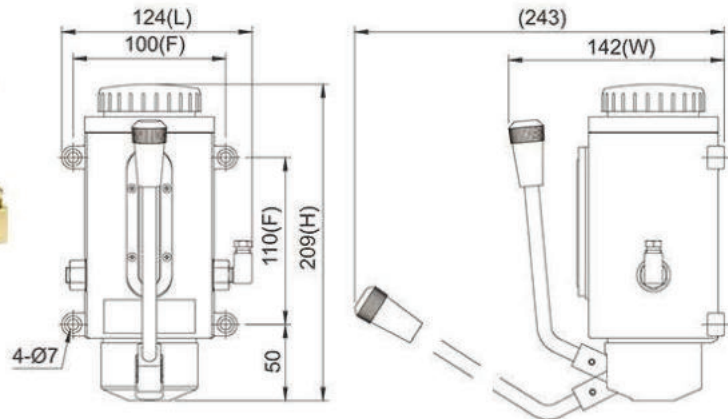

Dimensional Drawing of CLA-8-R-H-1

◆ Features

1. The compact size of CLA makes the installation easy.
2. CLA discharges oil whenever its handle is pulled.
3. The outlet of CLA can be on either the right side or the left side of the handle. A dual-outlet model is also available for selection.
4. CLA has a reverse stopper that prevents the back-flow of oil.
5. CLA can work with machines that do not require oil feeding at a particular time.

◆ Technical Data & Dimensional Data

Model	Tank Capacity	Length (mm)	Width (mm)	Height (mm)	Mounting Hole Distance (mm)	Max. Discharge Volume	Max. Operating Pressure	Suitable Viscosity	Discharge Bore	Outlet Number	N.W. (kg)
CLA-6	350cc	112	137	188	85x85	8cc/stroke	15 kgf/cm ²	Oil 32-68 cSt@40°C	ø4	1	1.23
										2	1.25
									ø6	1	1.24
										2	1.27
CLA-8	600cc	124	142	209	100x110	8cc/stroke	15 kgf/cm ²	Oil 32-68 cSt@40°C	ø4	1	1.50
										2	1.52
									ø6	1	1.50
										2	1.53

◆ Order Code

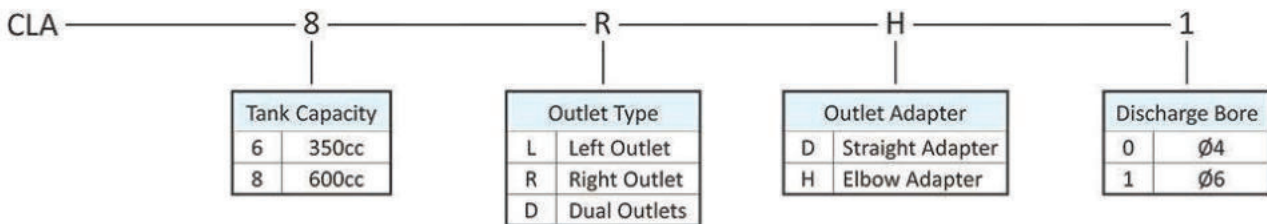

◆ Related Products



CTA Resistance Type Oil Manual Lubricator



CTA-3-H-0

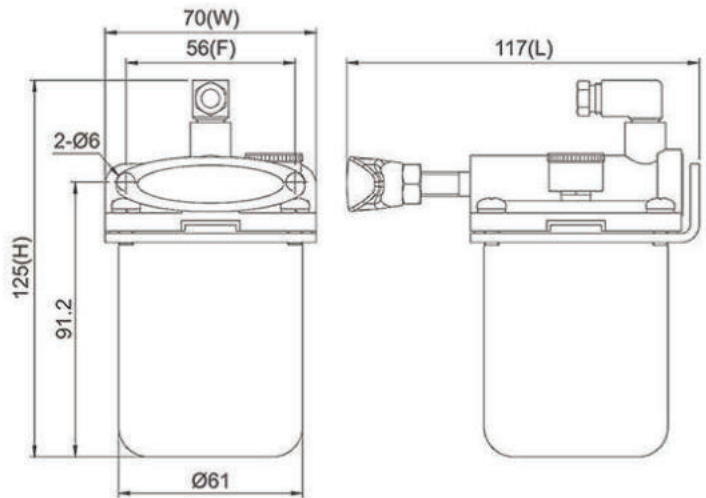

Dimensional Drawing of CTA-3-H-0



CTA-8-L-U-0 and CTA-8-R-U-0

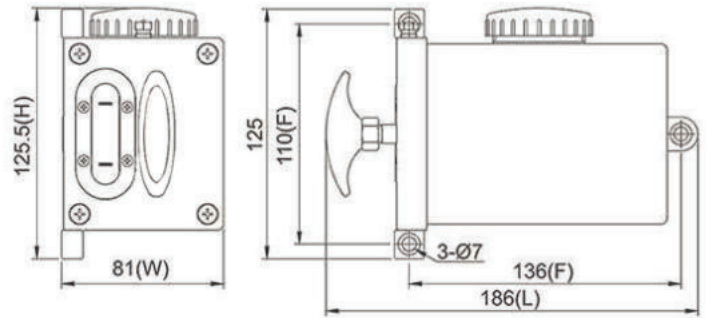

Dimensional Drawing of CTA-8-R-U-0

◆ Features

1. CTA-3, the smallest manual lubricator, is suitable for the machine that has limited space.
2. The outlet of CTA-8 can be on either the right side or the left side of the mounting holes.
3. CTA discharges oil whenever its handle is pulled.
4. CTA has a reverse stopper that prevents the back-flow of oil.
5. CTA can work with machines that do not require oil feeding at a particular time.

◆ Technical Data & Dimensional Data

Model	Tank Capacity	Mounting Hole Distance (mm)	Length (mm)	Width (mm)	Height (mm)	Discharge Bore	Max. Discharge Volume	Max. Operating Pressure	Suitable Viscosity	N.W. (kg)
CTA-3	180cc	56	117	70	123.0	Ø4	3cc/stroke	3.5	Oil	0.49
					130.0	Ø6				
CTA-8	650cc	110x136	186	81	125.5	Ø4	8cc/stroke	kgf/cm ²	32-68	1.01
					133.5	Ø6				

◆ Order Code (CTA-3)

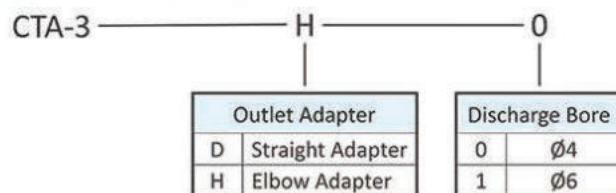

◆ Order Code (CTA-8)

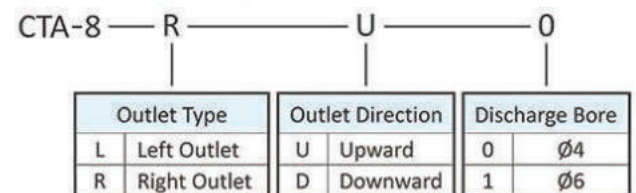

◆ Related Products



CKE Resistance Type Oil Manual Lubricator



CKE-8-L-0

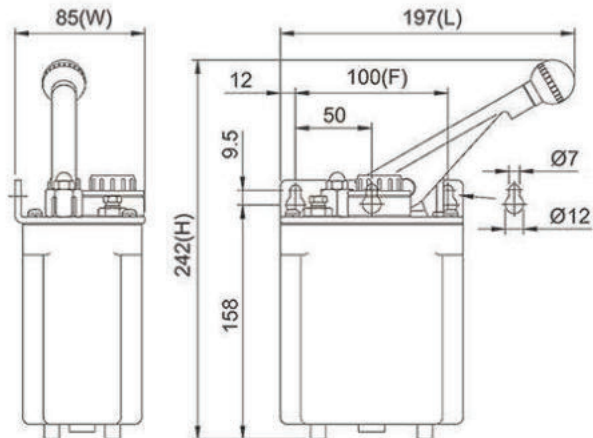

Dimensional Drawing of CKE-8-L-0



CKE-20-R-0

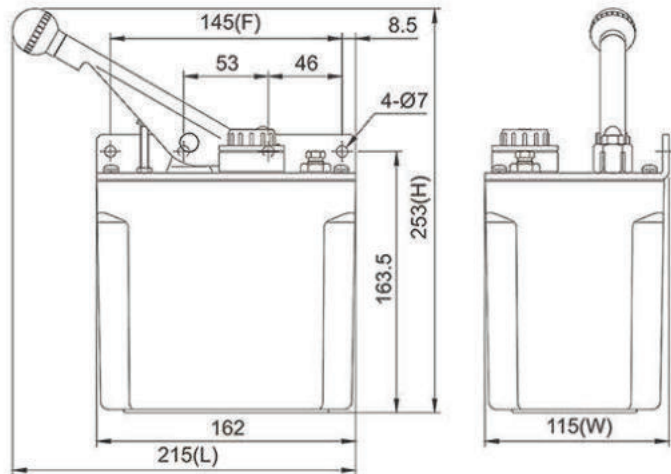

Dimensional Drawing of CKE-20-R-0

◆ Features

1. The compact size of CKE makes the installation easy.
2. CKE discharges oil whenever its handle is pushed down.
3. The outlet of CKE can be on either the right side or the left side of the handle.
4. CKE has a reverse stopper that prevents the back-flow of oil.
5. CKE can work with machines that do not require oil feeding at a particular time.

◆ Technical Data & Dimensional Data

Model	Tank Capacity	Mounting Hole Distance (mm)	Length (mm)	Width (mm)	Height (mm)	Outlet Type	Max. Discharge Volume	Max. Operating Pressure	Suitable Viscosity	Discharge Bore	N.W. (kg)			
CKE-8	1L	100	197	85	242	Left	8cc/stroke	5 kgf/cm ²	Oil 32-68 cSt@40°C	Ø4 Ø6	1.33			
			193	85	250	Right								
CKE-20	2L	145	215	115	253	Left								1.84
						Right								

◆ Order Code



◆ Related Products



CEN01 Resistance Type Oil Electric Lubricator PLC



CEN01-01-C-3

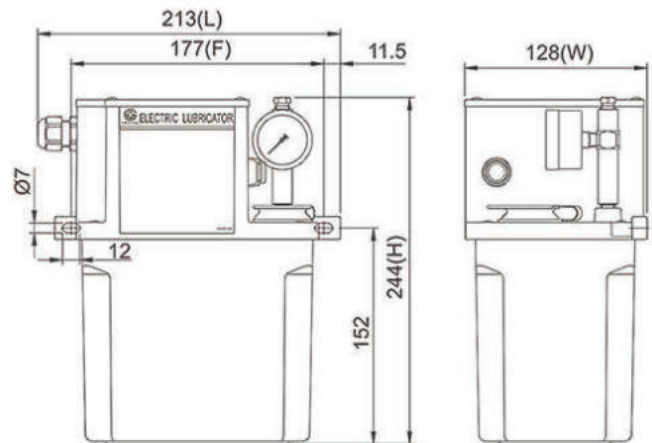

Dimensional Drawing of CEN01-01-C-3

◆ Features

1. The operation and interval time of CEN01 are controlled by PLC.
2. CEN01 has a pressure gauge that enables the user to check the operating pressure easily.
3. CEN01 has a 1kgf/cm² NC contact socket pressure switch that detects the operating pressure automatically and send signals when the pressure is below the preset value.
4. CEN01 has a NC contact float switch that detects the oil level automatically and sends signals when the oil level is low.
5. CEN01 has a spark quencher that prevents the spark of switch contacts and the interference of surge voltage with the PLC and prolongs the service life.
6. CEN01 has a feed-oil button, which can be used as manual oil feeding for less than 3 minutes to avoid overloading the motor.
7. CEN01 has a thermal control that shuts down the motor for about 5 minutes when the motor is overheated.

◆ Order Code

CEN01 - 01 - C - 3 - ※

Tank Capacity (Material)	
01	2L (Resin)
02	2L (Alum.)
03	3L (Resin)
04	4L (Resin)
05	4L (Alum.)
08	8L (Iron)

Voltage	
A	110V, 60Hz
B	220V, 50Hz
C	220V, 60Hz

Discharge Bore	
0	Ø4
1	Ø6
2	Ø4 W/P.G.
3	Ø6 W/P.G.

※ P.G. = Pressure Gauge

Special Request	
B	Add a Buzzer
PO	NO Contact Pressure Switch
SO	NO Contact Float Switch
Z	Increase Discharge Volume to 260cc/min

◆ Dimensional Data

Tank Capacity	Tank Material	Length (mm)	Width (mm)	Height (mm)	Mounting Hole Distance (mm)	N.W. (kg)
2L	Resin	213	128	244	177	3.40
2L	Alum.	221	150	234	95x200	4.55
3L	Resin	227	167	248	205	3.85
4L	Resin	277	162	259	250	4.30
4L	Alum.	297	170	253	95x280	5.30
8L	Iron	355	201	270	95x338	7.95

◆ Wiring Diagram

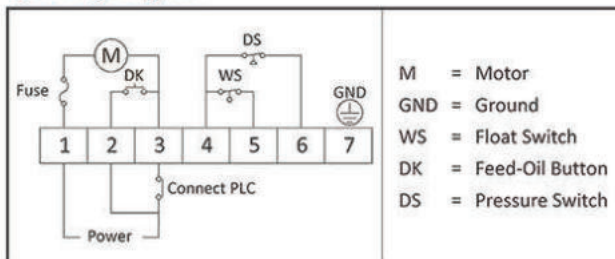

◆ Technical Data

Motor Power	30±3W	
Voltage	110V	220V
Ampere	2A	1A
Hertz	60Hz	50Hz, 60Hz
Max. Discharge Volume	130cc/min, 260cc/min	
Max. Operating Pressure	15kgf/cm ²	
Discharge Bore	Ø4, Ø6	
Float Switch	NC Contact (NO Contact on request)	
Pressure Switch	NC Contact (NO Contact on request)	
Suitable Viscosity	Oil, 32-68 cSt@40°C	

◆ Related Products



CESG01 Resistance Type Oil Electric Lubricator

PLC



CESG01-01-C-3

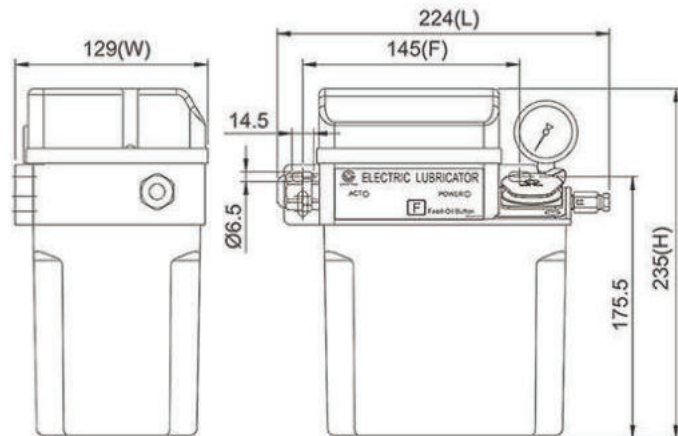

Dimensional Drawing of CESG01-01-C-3

◆ Features

1. The operation and interval time of CESG01 are controlled by PLC.
2. CESG01 has a pressure gauge that enables the user to check the operating pressure easily.
3. CESG01 has a NC contact float switch that detects the oil level automatically and sends signals when the oil level is low.
4. CESG01 has a feed-oil button (F button), which can be used as manual oil feeding for less than 3 minutes to avoid overloading the motor.
5. CESG01 has a thermal control that shuts down the motor for about 5 minutes when the motor is overheated.
6. A 1kgf/cm² socket pressure switch can be added to CESG01 on request to detect the operating pressure automatically.

◆ Order Code

CESG01 - 01 — C — 3 — ※

Tank Capacity (Material)		Voltage		Discharge Bore	
01	2L (Resin)	A	110V, 60Hz	0	∅4
02	2L (Alum.)	B	220V, 50Hz	1	∅6
03	3L (Resin)	C	220V, 60Hz	2	∅4 W/P.G.
04	4L (Resin)			3	∅6 W/P.G.
05	4L (Alum.)				
08	8L (Iron)				

※ P.G. = Pressure Gauge

Special Request	
PC	Add a NC Contact Pressure Switch
PO	Add a NO Contact Pressure Switch
SO	NO Contact Float Switch
Z	Increase Discharge Volume to 260cc/min

◆ Dimensional Data

Tank Capacity	Tank Material	Length (mm)	Width (mm)	Height (mm)	Mounting Hole Distance (mm)	N.W. (kg)
2L	Resin	224	129	235	145	2.70
2L	Alum.	224	150	225	95x200	3.80
3L	Resin	227	167	239	205	3.15
4L	Resin	277	162	250	250	3.60
4L	Alum.	297	170	244	95x280	4.60
8L	Iron	355	201	261	95x338	7.25

◆ Wiring Diagram

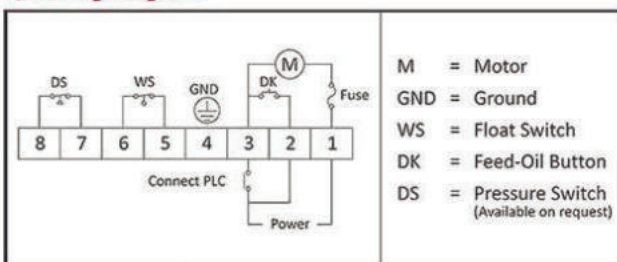

◆ Technical Data

Motor Power	25±3W	
Voltage	110V	220V
Ampere	1.8A	0.9A
Hertz	60Hz	50Hz, 60Hz
Max. Discharge Volume	130cc/min, 260cc/min	
Max. Operating Pressure	15kgf/cm ²	
Discharge Bore	∅4, ∅6	
Float Switch	NC Contact (NO Contact on request)	
Pressure Switch	Optional (NC or NO Contact)	
Suitable Viscosity	Oil, 32-68 cSt@40°C	

◆ Related Products



CEV Resistance Type Oil Electric Lubricator PLC



CEV-03-C-25-3



CEV-02-C-25-3



CEV-08-C-25-3-F-L-PC

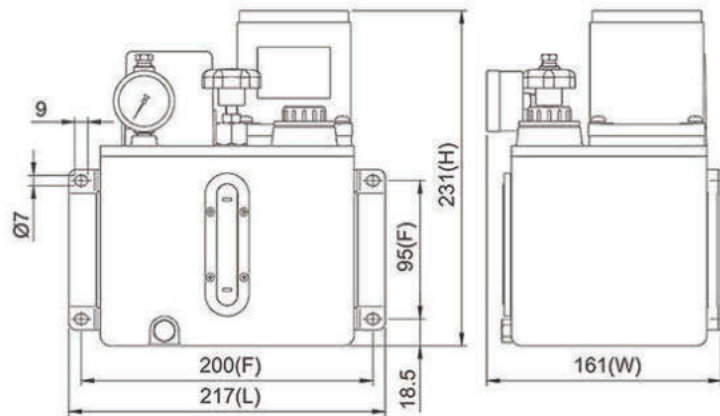

Dimensional Drawing of CEV-02-C-25-3

◆ Features

1. The operation and interval time of CEV are controlled by PLC.
2. CEV has a pressure gauge that enables the user to check the operating pressure easily.
3. CEV has a NC contact float switch that detects the oil level automatically and sends signals when the oil level is low.
4. CEV has a pressure-regulating valve that enables the user to adjust the operating pressure.
5. The gear pump of CEV is made of special aluminum alloy and assembled with the induction motor to provide stable output pressure, low operating noise, and long service life.
6. The CEV with 3L and above oil tank can be added with the following parts on request.
 - A 1kgf/cm² socket pressure switch that detects the operating pressure automatically.
 - A feed-oil button can be used for manual oil feeding.
 - An indicator light that shows when CEV discharges oil.

◆ Dimensional Data

Motor Power	Tank Capacity	Tank Material	Length (mm)	Width (mm)	Height (mm)	Mounting Hole Distance (mm)	N.W. (kg)
25W	2L	Aluminum	217	161	231	95x200	5.50
	3L	Resin	230	165	241	205	4.65
	4L	Resin	275	159	252	250	5.00
	4L	Aluminum	297	170	251	95x280	5.85
	8L	Iron	355	201	271	95x338	9.00
60W	4L	Aluminum	297	175	311	95x280	7.45
	8L	Iron	355	201	331	95x338	10.20

CEV Resistance Type Oil Electric Lubricator PLC

◆ Technical Data

Motor Power	25W			60W		
Voltage	1Ø110V	1Ø220V	Three Phase	1Ø110V	1Ø220V	Three Phase
Ampere	0.6A	0.3A	0.3A	1.2A	0.6A	0.6A
Max. Discharge Volume	250cc/min			500cc/min		
Max. Operating Pressure	15kgf/cm ²			30kgf/cm ²		
Hertz	50/60Hz Compatible					
Discharge Bore	Ø4, Ø6					
Float Switch	NC Contact (NO Contact on request)					
Pressure Switch	Optional (NC or NO Contact)					
Suitable Viscosity	Oil, 32-68 cSt@40°C					

◆ Order Code

CEV — 02 — C — 25 — 3 — ※

Tank Capacity (Material)	
01	2L (Resin)
02	2L (Alum.)
03	3L (Resin)
04	4L (Resin)
05	4L (Alum.)
08	8L (Iron)

Voltage	
A	1Ø110V
C	1Ø220V
D	3Ø220/380V
E	3Ø220/440V
F	3Ø208/415V
G	3Ø230/460V
H	3Ø240/480V
M	3Ø220V
N	3Ø380V
X	Special Voltage

Discharge Bore	
0	Ø4
1	Ø6
2	Ø4 W/Pressure Gauge
3	Ø6 W/Pressure Gauge

Special Request	
F	Add a Feed-Oil Button
L	Add a Power Indicator Light
PC	Add a NC Contact Pressure Switch
PO	Add a NO Contact Pressure Switch
SO	NO Contact Float Switch

Motor Power	
25	25W
60	60W (Available for 4L metal tank and above only)
90	90W (Available for 4L metal tank and above only)

- ※ A standard dual-voltage motor is connected for low voltage. Please specify if you need it to be connected for high voltage when placing an order.
- ※ Special request codes F, L, PC, and PO are only available for the CEV with 3L and above oil tanks.

◆ Wiring Diagram

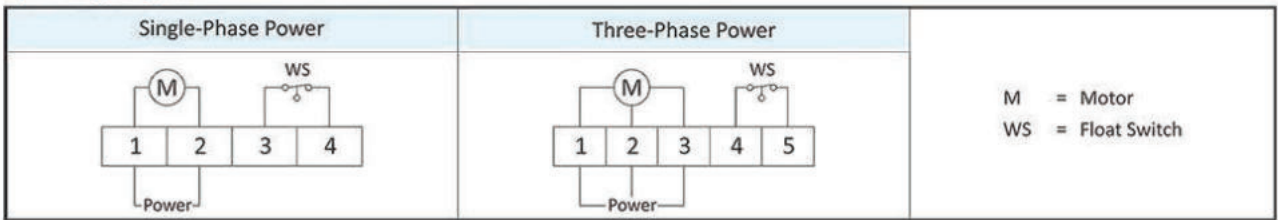

- ※ For the CEV with a feed-oil button, an indicator light, and a pressure switch, please follow the particular wiring diagram on the CEV.
- ※ The motor shaft is marked with a red dot. When wiring the three-phase-voltage CEV, please note the motor should rotate anticlockwise. If the motor rotates clockwise, please switch the position of any two of the power wires and rewire them.

◆ Related Products



CESP Resistance Type Oil Electric Lubricator Timer



CESP-01-C-1-2

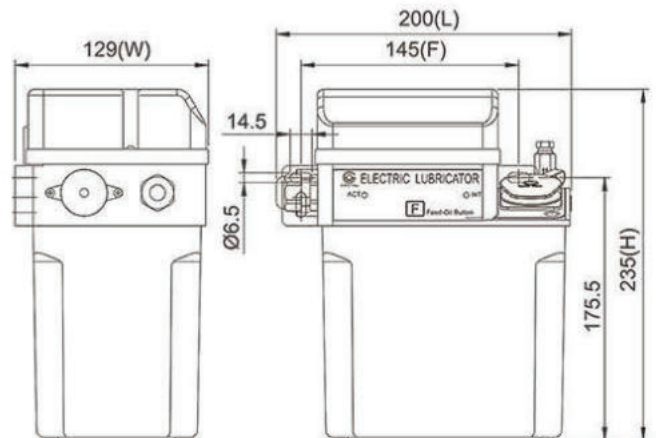

Dimensional Drawing of CESP-01-C-1-2

◆ Features

- The time adjusters are inside the control box of CESP. There are eight kinds of operation time and interval time for selection.
- There are operation (ACT) and interval (INT) indicators on the control box.
- There are two operation modes after the power of CESP is on. The standard mode is turn-on-interval.
 - Turn-on-feeding: Operation time starts first after the power is on.
 - Turn-on-interval: Interval time starts first after the power is on.
- Turn-on-interval model has a memory function. If the power is suddenly off during the interval time, CESP will continue to operate from the remaining interval time after restarting, which can effectively avoid over-lubrication.
- CESP has a NC contact float switch that detects the oil level automatically and sends signals when the oil level is low.
- CESP has a buzzer that sends an alarm sound when the oil level is low.
- CESP has a feed-oil button (F button), which can be used as manual oil feeding for less than 3 minutes to avoid overloading the motor.
- CESP has a thermal control that shuts down the motor for about 5 minutes when the motor is overheated.

◆ Order Code

CESP — 01 — C — 1 — 2

Tank Capacity (Material)	Discharge Bore	Voltage	Operation Mode
01 2L (Resin)	0 Ø4	A 110V, 60Hz	1 Turn-on-Feeding
02 2L (Alum.)	1 Ø6	B 220V, 50Hz	2 Turn-on-Interval
03 3L (Resin)	2 Ø4 W/Pressure Gauge	C 220V, 60Hz	
04 4L (Resin)	3 Ø6 W/Pressure Gauge		
05 4L (Alum.)			
08 8L (Iron)			

◆ Dimensional Data

Tank Capacity	Tank Material	Length (mm)	Width (mm)	Height (mm)	Mounting Hole Distance (mm)	N.W. (kg)
2L	Resin	200	129	235	145	2.30
2L	Alum.	221	150	225	95x200	3.50
3L	Resin	227	167	239	205	2.80
4L	Resin	277	162	250	250	3.20
4L	Alum.	297	170	244	95x280	4.20
8L	Iron	355	201	261	95x338	6.85

◆ Technical Data

Operation Time	2, 3, 5, 10, 15, 20, 25, 30 sec
Interval Time	3, 5, 10, 15, 20, 30, 60, 180 min
Motor Power	20±3W
Voltage	110V 220V
Ampere	1.5A 1.0A
Hertz	60Hz 50Hz, 60Hz
Max. Discharge Volume	130cc/min
Max. Operating Pressure	10kgf/cm ²
Discharge Bore	Ø4, Ø6
Float Switch	NC Contact
Suitable Viscosity	Oil, 32-68 cSt@40°C

◆ Wiring Diagram

Power	Ground	Abnormal Output		
POWER	GND(P.E)	COM	NC(B)	NO(A)
⊕	⊕	⊕	⊕	⊕

◆ Related Products



CESH Resistance Type Oil Electric Lubricator Timer



CESH-01-2-C-1-2

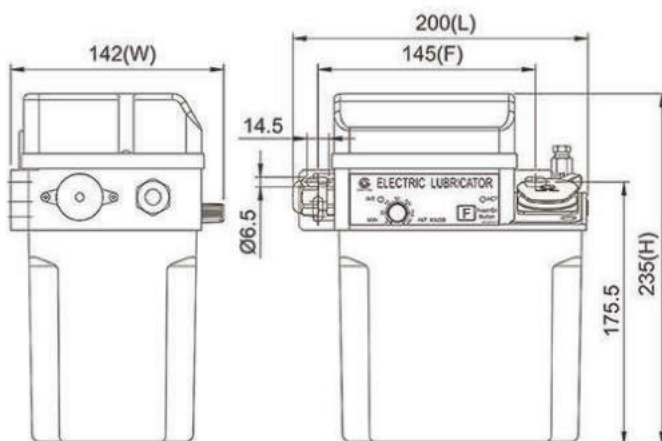

Dimensional Drawing of CESH-01-2-C-1-2

◆ Features

- The operation time of CESH is 10 seconds. Users can set the interval time by the time adjuster on the control box. There are operation (ACT) and interval (INT) indicators on the control box.
- There are two operation modes after the power of CESH is on. The standard mode is turn-on-interval.
 - Turn-on-feeding: Operation time starts first after the power is on.
 - Turn-on-interval: Interval time starts first after the power is on.
- Turn-on-interval model has a memory function. If the power is suddenly off during the interval time, CESH will continue to operate from the remaining interval time after restarting, which can effectively avoid over-lubrication.
- CESH has a NC contact float switch that detects the oil level automatically and sends signals when the oil level is low.
- CESH has a buzzer that sends an alarm sound when the oil level is low.
- CESH has a feed-oil button (F button), which can be used as manual oil feeding for less than 3 minutes to avoid overloading the motor.
- CESH has a thermal control that shuts down the motor for about 5 minutes when the motor is overheated.

◆ Order Code

CESH — 01 — 2 — C — 1 — 2

Tank Capacity (Material)	
01	2L (Resin)
02	2L (Alum.)
03	3L (Resin)
04	4L (Resin)
05	4L (Alum.)
08	8L (Iron)

Voltage	
A	110V, 60Hz
B	220V, 50Hz
C	220V, 60Hz

Discharge Bore	
0	Ø4
1	Ø6
2	Ø4 W/Pressure Gauge
3	Ø6 W/Pressure Gauge

ACT x INT	
1	10 sec x 60 min
2	10 sec x 180 min

Operation Mode	
1	Turn-on-Feeding
2	Turn-on-Interval

◆ Wiring Diagram

Abnormal Output			Ground	Power
NO(A)	NC(B)	COM	GND(P.E)	POWER
⊕	⊕	⊕	⊕	⊕

◆ Dimensional Data

Tank Capacity	Tank Material	Length (mm)	Width (mm)	Height (mm)	Mounting Hole Distance (mm)	N.W. (kg)
2L	Resin	200	142	235	145	2.30
2L	Alum.	221	153	225	95x200	3.50
3L	Resin	227	167	239	205	2.80
4L	Resin	277	162	250	250	3.20
4L	Alum.	297	170	244	95x280	4.20
8L	Iron	355	201	261	95x338	6.85

◆ Technical Data

Operation Time	10 sec	
Interval Time	1-60 min, 1-180 min	
Motor Power	20±3W	
Voltage	110V	220V
Ampere	1.5A	1.0A
Hertz	60Hz	50Hz, 60Hz
Max. Discharge Volume	130cc/min	
Max. Operating Pressure	10kgf/cm ²	
Discharge Bore	Ø4, Ø6	
Float Switch	NC Contact	
Suitable Viscosity	Oil, 32-68 cSt@40°C	

◆ Related Products



P. 81

P. 82

P. 87

P. 109

P. 111

P. 120

P. 124

P. 123

P. 127

CESD Resistance Type Oil Electric Lubricator Timer



CESD-01-2-C-1-2

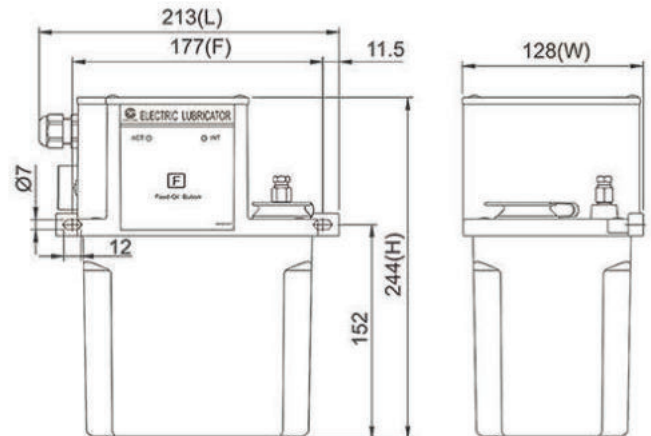

Dimensional Drawing of CESD-01-2-C-1-2

◆ Features

- The operation and interval time adjusters are inside the control box of CESD. There are operation (ACT) and interval (INT) indicators on the control box.
- There are two operation modes after the power of CESD is on. The standard mode is turn-on-interval.
 - Turn-on-feeding: Operation time starts first after the power is on.
 - Turn-on-interval: Interval time starts first after the power is on.
- Turn-on-interval model has a memory function. If the power is suddenly off during the interval time, CESD will continue to operate from the remaining interval time after restarting, which can effectively avoid over-lubrication.
- CESD has a NC contact float switch that detects the oil level automatically and sends signals when the oil level is low.
- CESD has a buzzer that sends an alarm sound when the oil is below the minimum level.
- CESD has a feed-oil button (F button), which can be used as manual oil feeding for less than 3 minutes to avoid overloading the motor.
- CESD has a thermal control that shuts down the motor for about 5 minutes when the motor is overheated.

◆ Order Code

CESD — 01 — 2 — C — 1 — 2

Tank Capacity (Material)	
01	2L (Resin)
02	2L (Alum.)
03	3L (Resin)
04	4L (Resin)
05	4L (Alum.)
08	8L (Iron)

Voltage	
A	110V, 60Hz
B	220V, 50Hz
C	220V, 60Hz

Discharge Bore	
0	∅4
1	∅6
2	∅4 W/Pressure Gauge
3	∅6 W/Pressure Gauge

ACT x INT	
1	60 sec x 60 min
2	60 sec x 180 min
3	60 sec x 12 hours
4	60 sec x 72 hours

Operation Mode	
1	Turn-on-Feeding
2	Turn-on-Interval

◆ Wiring Diagram

Abnormal Output			Ground	Power
NO(A)	NC(B)	COM	GND(P.E)	POWER
⊕	⊕	⊕	⊕	⊕ ⊕

◆ Dimensional Data

Tank Capacity	Tank Material	Length (mm)	Width (mm)	Height (mm)	Mounting Hole Distance (mm)	N.W. (kg)
2L	Resin	213	128	244	177	3.00
2L	Alum.	221	150	234	95x200	4.15
3L	Resin	227	167	248	205	3.45
4L	Resin	277	162	259	250	3.90
4L	Alum.	297	170	253	95x280	4.90
8L	Iron	355	201	270	95x338	7.55

◆ Technical Data

Operation Time	3-60 sec	
Interval Time	1-60min, 1-180min, 1-12hr, 1-72hr	
Motor Power	12±3W	
Voltage	110V	220V
Ampere	1.5A	0.7A
Hertz	60Hz	50Hz, 60Hz
Max. Discharge Volume	130cc/min	
Max. Operating Pressure	8kgf/cm ²	
Discharge Bore	∅4, ∅6	
Float Switch	NC Contact	
Suitable Viscosity	Oil, 32-68 cSt@40°C	

◆ Related Products



P. 81

P. 82

P. 87

P. 109

P. 111

P. 120

P. 124

P. 123

P. 127

CESW Resistance Type Oil Electric Lubricator Timer



CESW-01-2-C-1-2

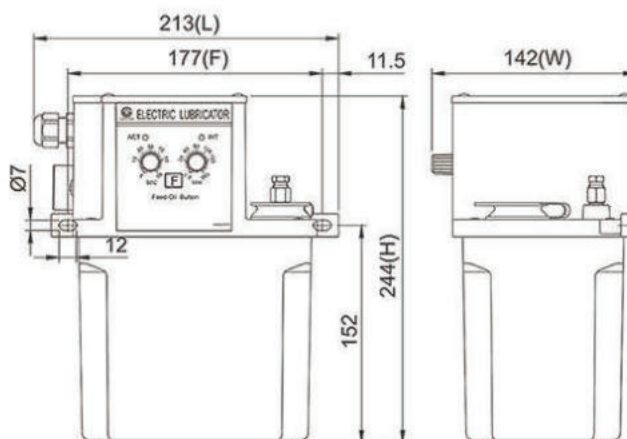

Dimensional Drawing of CESW-01-2-C-1-2

◆ Features

- The operation and interval time adjusters are on the control box of CESW. There are operation (ACT) and interval (INT) indicators on the control box.
- There are two operation modes after the power of CESW is on. The standard mode is turn-on-interval.
 - Turn-on-feeding: Operation time starts first after the power is on.
 - Turn-on-interval: Interval time starts first after the power is on.
- Turn-on-interval model has a memory function. If the power is suddenly off during the interval time, CESW will continue to operate from the remaining interval time after restarting, which can effectively avoid over-lubrication.
- CESW has a NC contact float switch that detects the oil level automatically and sends signals when the oil level is low.
- CESW has a buzzer that sends an alarm sound when the oil level is low.
- CESW has a feed-oil button (F button), which can be used as manual oil feeding for less than 3 minutes to avoid overloading the motor.
- CESW has a thermal control that shuts down the motor for about 5 minutes when the motor is overheated.

◆ Order Code

CESW — 01 — 2 — C — 1 — 2

Tank Capacity (Material)	
01	2L (Resin)
02	2L (Alum.)
03	3L (Resin)
04	4L (Resin)
05	4L (Alum.)
08	8L (Iron)

Voltage	
A	110V, 60Hz
B	220V, 50Hz
C	220V, 60Hz

Discharge Bore	
0	Ø4
1	Ø6
2	Ø4 W/Pressure Gauge
3	Ø6 W/Pressure Gauge

ACT x INT	
1	60 sec x 60 min
2	60 sec x 180 min
3	60 sec x 12 hours
4	60 sec x 72 hours

Operation Mode	
1	Turn-on-Feeding
2	Turn-on-Interval

◆ Wiring Diagram

Abnormal Output			Ground	Power	
NO(A)	NC(B)	COM	GND(P.E)	POWER	
⊕	⊕	⊕	⊕	⊕	⊕

◆ Dimensional Data

Tank Capacity	Tank Material	Length (mm)	Width (mm)	Height (mm)	Mounting Hole Distance (mm)	N.W. (kg)
2L	Resin	213	142	244	177	3.00
2L	Alum.	221	156	234	95x200	4.15
3L	Resin	227	167	248	205	3.45
4L	Resin	277	162	259	250	3.90
4L	Alum.	297	173	253	95x280	4.90
8L	Iron	355	201	270	95x338	7.55

◆ Technical Data

Operation Time	3-60 sec	
Interval Time	1-60min, 1-180min, 1-12hr, 1-72hr	
Motor Power	12±3W	
Voltage	110V	220V
Ampere	1.5A	0.7A
Hertz	60Hz	50Hz, 60Hz
Max. Discharge Volume	130cc/min	
Max. Operating Pressure	8kgf/cm ²	
Discharge Bore	Ø4, Ø6	
Float Switch	NC Contact	
Suitable Viscosity	Oil, 32-68 cSt@40°C	

◆ Related Products

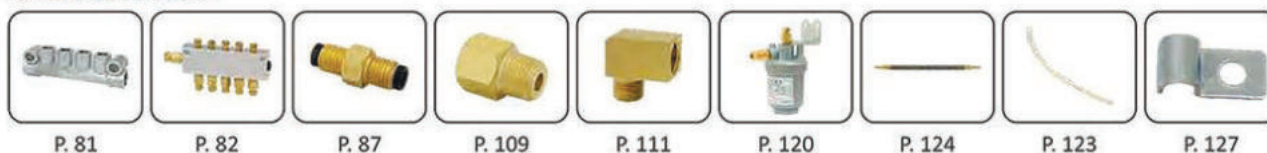

CEN02 Resistance Type Oil Timer Electric Lubricator



CEN02-01-2-C-3

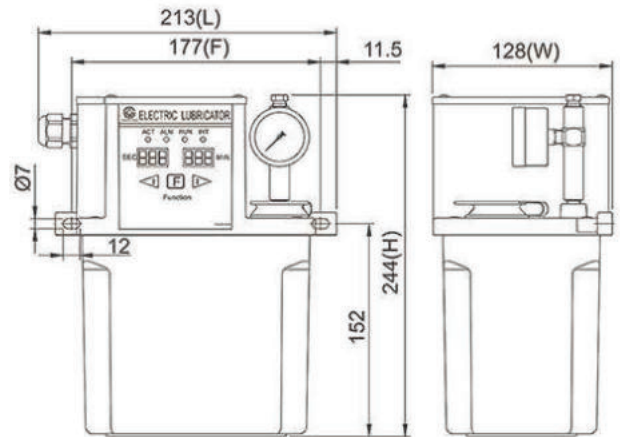

Dimensional Drawing of CEN02-01-2-C-3

◆ Features

- CEN02 has a timer that controls its operation and interval time. The control box has a built-in buzzer that sends an alarm sound when the oil level is low. The control box also has four indicators, operation (ACT), alarm (ALM), immediate lubrication (RUN), and interval (INT).
- CEN02 can memorize the set value of operation time and interval time.
- There are two operation modes after the power of CEN02 is on. The standard mode is turn-on-feeding.
 - Turn-on-feeding: Operation time starts first after the power is on.
 - Turn-on-interval: Interval time starts first after the power is on.
- Turn-on-interval model has a memory function. If the power is suddenly off during the interval time, CEN02 will continue to operate from the remaining interval time after restarting, which can effectively avoid over-lubrication.
- CEN02 has a pressure gauge that enables the user to check the operating pressure easily.
- CEN02 has a NC contact float switch that detects the oil level automatically and sends signals when the oil level is low.
- CEN02 has a feed-oil button (F button), which can be used as manual oil feeding for less than 3 minutes to avoid overloading the motor.
- CEN02 has a thermal control that shuts down the motor for about 5 minutes when the motor is overheated.
- A 1kgf/cm² socket pressure switch can be added to CEN02 on request to detect the operating pressure automatically.

◆ Order Code

CEN02 - 01 - 2 - C - 3 - ※

Tank Capacity (Material)	ACT x INT	Voltage
01 2L (Resin)	1 sec x sec	A 110V, 60Hz
02 2L (Alum.)	2 sec x min	B 220V, 50Hz
03 3L (Resin)		C 220V, 60Hz
04 4L (Resin)		
05 4L (Alum.)		
08 8L (Iron)		

Discharge Bore	
0	∅4
1	∅6
2	∅4 W/Pressure Gauge
3	∅6 W/Pressure Gauge

Special Request	
2	Turn-on-Interval Operation Mode
B	Add a Larger Buzzer
PC	Add a NC Contact Pressure Switch
Z	Increase Discharge Volume to 260cc/min

◆ Dimensional Data

Tank Capacity	Tank Material	Length (mm)	Width (mm)	Height (mm)	Mounting Hole Distance (mm)	N.W. (kg)
2L	Resin	213	128	244	177	3.45
2L	Alum.	221	150	234	95x200	4.60
3L	Resin	227	167	248	205	3.90
4L	Resin	277	162	259	250	4.35
4L	Alum.	297	170	253	95x280	5.35
8L	Iron	355	201	270	95x338	8.00

◆ Technical Data

Operation Time	1-999 sec	
Interval Time	1-999 sec, 1-999 min	
Motor Power	30±3W	
Voltage	110V	220V
Ampere	2A	1A
Hertz	60Hz	50Hz, 60Hz
Max. Discharge Volume	130cc/min, 260cc/min	
Max. Operating Pressure	15kgf/cm ²	
Discharge Bore	∅4, ∅6	
Float Switch	NC Contact	
Pressure Switch	Optional (NC Contact)	
Suitable Viscosity	Oil, 32-68 cSt@40°C	

◆ Wiring Diagram

Abnormal Output			Ground	Power
NO(A)	NC(B)	COM	GND(P.E)	POWER
⊕	⊕	⊕	⊕	⊕

◆ Related Products



P. 81

P. 82

P. 87

P. 109

P. 111

P. 119

P. 120

P. 124

P. 127

CESG02 Resistance Type Oil Electric Lubricator

Timer



CESG02-01-2-C-3

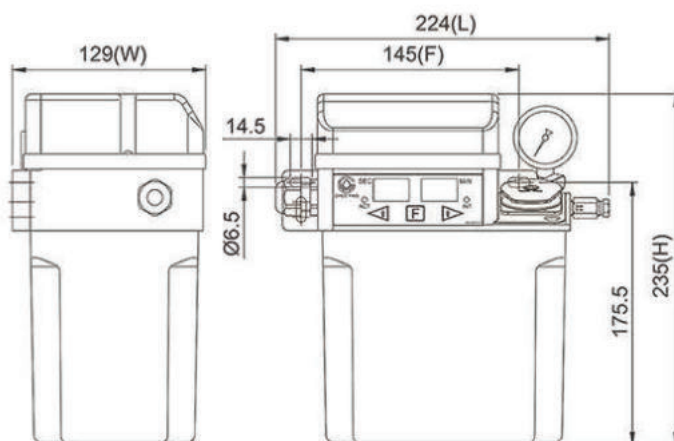

Dimensional Drawing of CESG02-01-2-C-3

◆ Features

- CESG02 has a timer that controls its operation and interval time. The control box has a built-in buzzer that sends an alarm sound when the oil level is low. The control box also has two indicators, operation (ACT), and interval (INT).
- CESG02 can memorize the set value of operation time and interval time.
- There are two operation modes after the power of CESG02 is on. The standard mode is turn-on-feeding.
 - Turn-on-feeding: Operation time starts first after the power is on.
 - Turn-on-interval: Interval time starts first after the power is on.
- Turn-on-interval model has a memory function. If the power is suddenly off during the interval time, CESG02 will continue to operate from the remaining interval time after restarting, which can effectively avoid over-lubrication.
- CESG02 has a pressure gauge that enables the user to check the operating pressure easily.
- CESG02 has a NC contact float switch that detects the oil level automatically and sends signals when the oil level is low.
- CESG02 has a feed-oil button (F button), which can be used as manual oil feeding for less than 3 minutes to avoid overloading the motor.
- CESG02 has a thermal control that shuts down the motor for about 5 minutes when the motor is overheated.
- A 1kgf/cm² socket pressure switch can be added to CESG02 on request to detect the operating pressure automatically.

◆ Order Code

CESG02 - 01 - 2 - C - 3 - ※

Tank Capacity (Material)		ACT x INT		Voltage	
01	2L (Resin)	1	sec x min	A	110V, 60Hz
02	2L (Alum.)	2	sec x hour	B	220V, 50Hz
03	3L (Resin)			C	220V, 60Hz
04	4L (Resin)				
05	4L (Alum.)				
08	8L (Iron)				

Discharge Bore	
0	Ø4
1	Ø6
2	Ø4 W/Pressure Gauge
3	Ø6 W/Pressure Gauge

Special Request	
2	Turn-on-Interval Operation Mode
B	Add a Larger Buzzer
PC	Add a NC Contact Pressure Switch
Z	Increase Discharge Volume to 260cc/min

◆ Wiring Diagram

Abnormal Output			Ground	Power
NO(A)	NC(B)	COM	GND(P.E)	POWER
⊕	⊕	⊕	⊕	⊕ ⊕

◆ Related Products

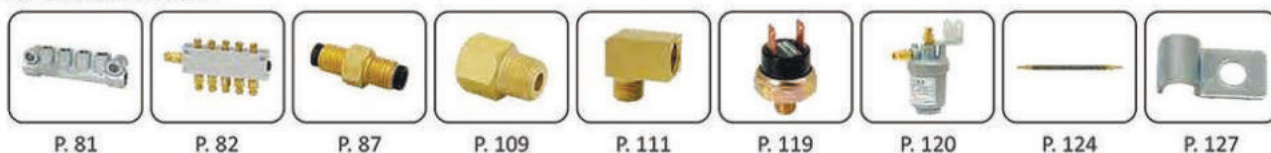

◆ Dimensional Data

Tank Capacity	Tank Material	Length (mm)	Width (mm)	Height (mm)	Mounting Hole Distance (mm)	N.W. (kg)
2L	Resin	224	129	235	145	2.80
2L	Alum.	224	150	225	95x200	3.90
3L	Resin	227	167	239	205	3.25
4L	Resin	277	162	250	250	3.70
4L	Alum.	297	170	244	95x280	4.70
8L	Iron	355	201	261	95x338	7.35

◆ Technical Data

Operation Time	1-999 sec	
Interval Time	1-999 min, 1-999 hour	
Motor Power	25±3W	
Voltage	110V	220V
Ampere	1.8A	0.9A
Hertz	60Hz	50Hz, 60Hz
Max. Discharge Volume	130cc/min, 260cc/min	
Max. Operating Pressure	15kgf/cm ²	
Discharge Bore	Ø4, Ø6	
Float Switch	NC Contact	
Pressure Switch	Optional (NC Contact)	
Suitable Viscosity	Oil, 32-68 cSt@40°C	

CENA Resistance Type Oil Electric Lubricator Timer



CENA-03-2-C-25-3

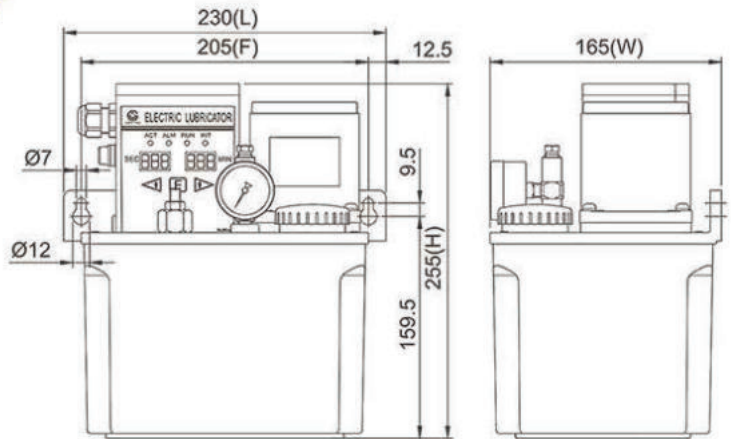

Dimensional Drawing of CENA-03-2-C-25-3

◆ Features

1. CENA has a timer that controls its operation and interval time. The control box has a built-in buzzer that sends an alarm sound when the oil level is low. The control box also has four indicators, operation (ACT), alarm (ALM), immediate lubrication (RUN), and interval (INT).
2. CENA can memorize the set value of operation time and interval time.
3. CENA has a pressure gauge that enables the user to check the operating pressure easily.
4. CENA has a NC contact float switch that detects the oil level automatically and sends signals when the oil level is low.
5. CENA has a pressure-regulating valve that enables the user to adjust the operating pressure.
6. CENA has a feed-oil button (F button), which can be used as manual oil feeding for less than 3 minutes to avoid overloading the motor.
7. CENA with 3L above tank can add a 1kgf/cm² socket pressure switch to detect the operating pressure automatically, which sends signals when the pressure is below the preset value.
8. The gear pump of CENA is made of special aluminum alloy and assembled with the induction motor to provide stable output pressure, low operating noise, and long service life. It meets the requirements of most large machines.

◆ Dimensional Data

Motor Power	Tank Capacity	Tank Material	Length (mm)	Width (mm)	Height (mm)	Mounting Hole Distance (mm)	N.W. (kg)
25W	2L	Aluminum	222	150	245	95x200	5.70
	3L	Resin	230	165	255	205	4.80
	4L	Resin	277	162	266	250	5.20
	4L	Aluminum	297	170	264	95x280	6.65
	8L	Iron	355	201	285	95x338	9.40
60W	4L	Aluminum	297	170	311	95x280	7.70
	8L	Iron	355	201	331	95x338	10.45

◆ Technical Data

Operation Time	1-999 sec			
Interval Time	1-999 sec, 1-999 min			
Motor Power	25W		60W	
Voltage	110V	220V	110V	220V
Ampere	0.6A	0.3A	1.2A	0.6A
Max. Discharge Volume	250cc/min		500cc/min	
Max. Operating Pressure	15kgf/cm ²		30kgf/cm ²	
Hertz	50/60Hz Compatible			
Discharge Bore	Ø4, Ø6			
Float Switch	NC Contact			
Pressure Switch	Optional (NC Contact)			
Suitable Viscosity	Oil, 32-68 cSt@40°C			

◆ Wiring Diagram

Abnormal Output			Ground	Power
NO(A)	NC(B)	COM	GND(P.E)	POWER
⊕	⊕	⊕	⊕	⊕ ⊕

◆ Order Code

CENA — 03 — 2 — C — 25 — 3 — ※

Tank Capacity (Material) 02 2L (Alum.) 03 3L (Resin) 04 4L (Resin) 05 4L (Alum.) 08 8L (Iron)	ACT x INT 1 sec x sec 2 sec x min	Motor Power 25 25W 60 60W 90 90W	Discharge Bore 0 Ø4 1 Ø6 2 Ø4 W/Pressure Gauge 3 Ø6 W/Pressure Gauge	Special Request B Add a Larger Buzzer PC Add a NC Contact Pressure Switch (Available for 3L and above tanks only)
Voltage A 110V C 220V		※ 60W and 90W motors are only available for CENA with a 4L metal tank and above.		

◆ Related Products



P. 81

P. 82

P. 87

P. 109

P. 111

P. 119

P. 120

P. 124

P. 127

CESMA/B, CESC, CESS (B) Interval Time Fixed Resistance Type Oil Electric Lubricator



◆ Dimensional Drawings

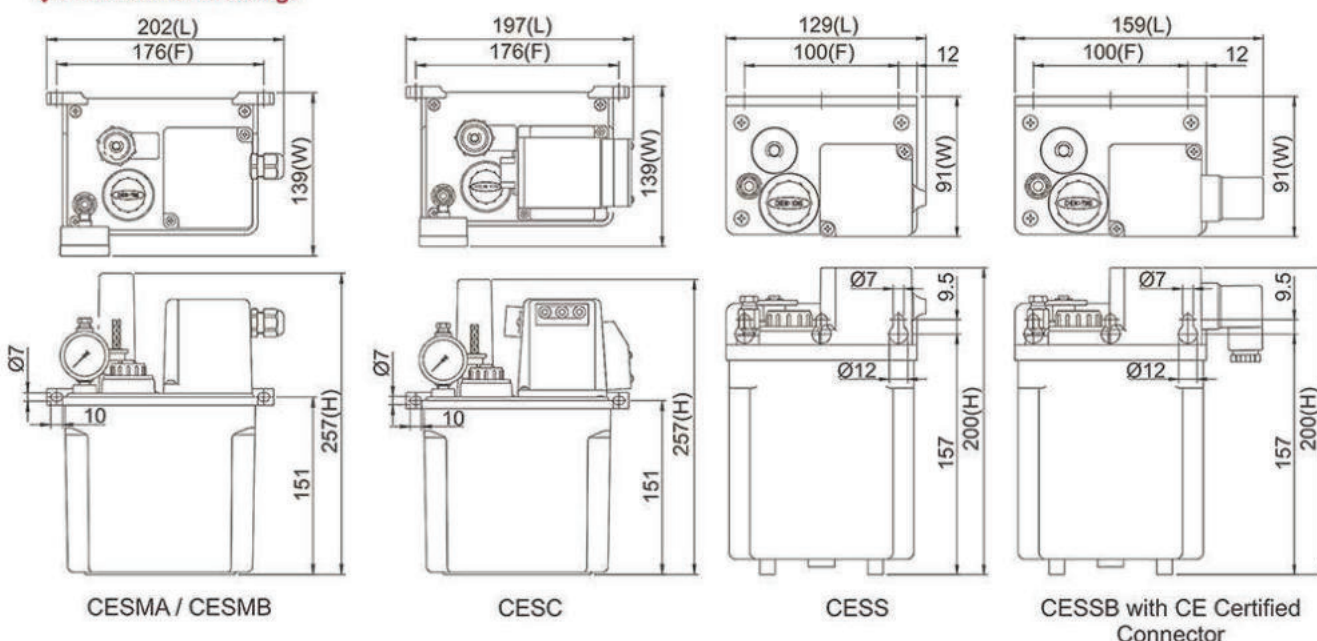

◆ Features

1. The interval time of CES series lubricators is controlled by the rotational speed of the small synchronous motor that no external controllers or timers are needed.
2. The discharge volume of CES series lubricators is adjustable.
3. CESMB and CESSB have NO contact float switches that detect the oil levels automatically and send signals when the oil levels are high.
4. CESC have a NC contact float switch that detects the oil level automatically and sends signals when the oil level is low.
5. The control box of CESC has three indicators that show power, action, and alarm.
6. A power indicator can be added to CESMA and CESMB on request to show when the power is on.
7. A CE certified connector can be added to CESSB on request to change the wiring method from external to internal.

◆ Dimensional and Equipment Data

Model	Tank Capacity	Length (mm)	Width (mm)	Height (mm)	Mounting Hole Distance (mm)	N.W. (kg)	Float Switch	Buzzer	Pressure Gauge	Control Box	Indicator Light	Wiring Method
CESMA	2L	202	139	257	176	1.84	X	X	O	X	Optional	Internal
CESMB		202	139	257	176	1.86	O	X	O	X	Optional	Internal
CESC		197	139	257	176	1.96	O	O	O	O	O	External
CESS	1L	129	91	200	100	1.28	X	X	X	X	X	External
CESSB		159	91	200	100	1.30	O	X	X	X	X	External

CESMA/B, CESC, CESS (B) Interval Time Fixed Resistance Type Oil Electric Lubricator

◆ Technical Data

Interval Time	2, 3, 5, 10, 15, 30, 60 min (Non-Adjustable) (2 min is not available for CESC.)	
Motor Power	4W	
Voltage	110V	220V
Ampere	0.10A	0.05A
Hertz	50/60Hz Compatible	
Max. Discharge Volume	CESMA, CESMB, CESC: 3-6cc Adjustable or 1-6cc Adjustable CESS, CESSB: 3cc Non-Adjustable or 1-3cc Adjustable	
Max. Operating Pressure	3kgf/cm ²	
Discharge Bore	ø4, ø6	
Float Switch	CESMB : NO Contact (NC Contact on request) CESC : NC Contact CESSB : NO Contact (NC Contact on request)	
Suitable Viscosity	Oil, 32-68 cSt@40°C	

◆ Order Code (CESMA, CESMB, CESC)

CESMA — 10 — C — 6 — 3 — ✕

Model	Interval Time	Voltage	Discharge Bore	Special Request
MA	02 2 min	A 110V	0 ø4	L Add a Power Indicator Light (Available for CESMA and CESMB only)
MB	03 3 min	C 220V	1 ø6	SC NC Contact Float Switch (Available for CESMB only)
C	05 5 min	Discharge Volume		
	10 10 min	1 1-6cc Adjustable		
	15 15 min	6 3-6cc Adjustable		
	30 30 min		2 ø4 W/Pressure Gauge	
	60 60 min		3 ø6 W/Pressure Gauge	

◆ Order Code (CESS, CESSB)

CESS — 10 — C — 3 — 1 — ✕

Model	Interval Time	Voltage	Discharge Volume	Discharge Bore	Special Request
S	02 2 min	A 110V	1 1-3cc Adjustable	0 ø4	H Add a CE Certified Connector (Available for CESSB only)
SB	03 3 min	C 220V	3 3cc Non-Adjustable	1 ø6	SC NC Contact Float Switch (Available for CESSB only)
	05 5 min				
	10 10 min				
	15 15 min				
	30 30 min				
	60 60 min				

◆ Wiring Diagram

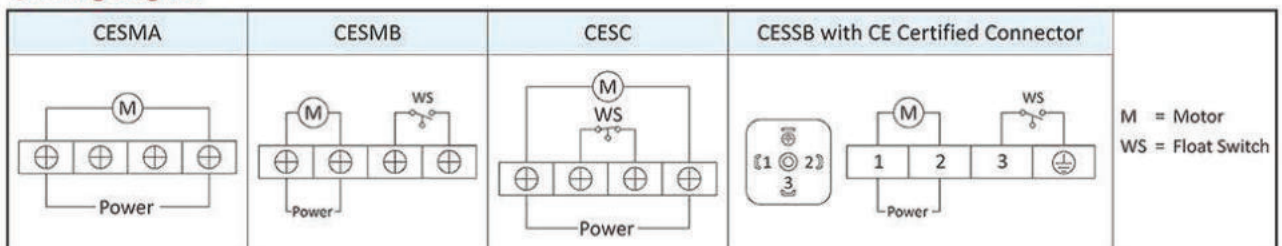

◆ Related Products

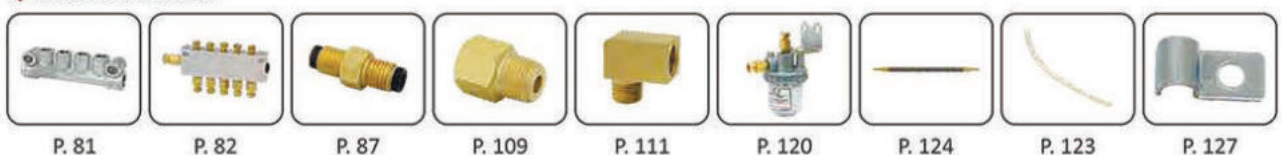

PNA Resistance Type Pneumatic Lubricator



PNA-01-3-0

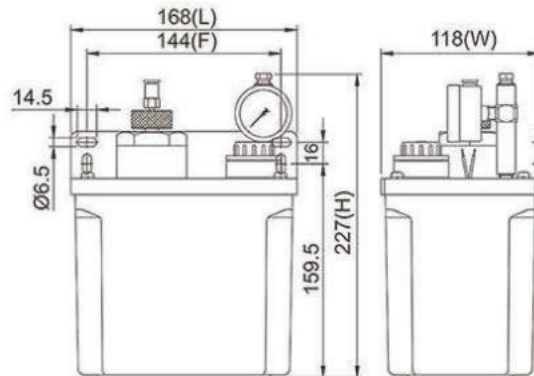

Dimensional Drawing of PNA-01-3-0



PNA-04-3-0-C-D

◆ Features

1. PNA is actuated pneumatically by a solenoid valve to discharge oil intermittently. The pneumatic pressure supply controls the output pressure of PNA.
2. PNA requires 4-8 kgf/cm² pneumatic pressure supply and 5 seconds above ON/OFF time of the solenoid valve to work functionally.
3. PNA has a pressure gauge that enables the user to check the operating pressure easily.
4. PNA has a NC contact float switch that detects the oil level automatically and sends signals when the oil level is low.
5. PNA has an oil volume adjuster that enables the user to adjust the discharge volume upon the demand.
6. A 1kgf/cm² socket pressure switch can be added to PNA on request to detect the operating pressure automatically.
7. A magnetic filter and a partition can be added to PNA on request to filter the oil that returns to the oil tank through the cyclic inlet.
 - 3L oil tank and above can add a magnetic filter.
 - 3L, 4L resin oil tanks, and 8L iron oil tanks can add a partition.

◆ Order Code

PNA — 01 — 3 — 0 — ※

Tank Capacity (Material)	
01	2L (Resin)
02	2L (Alum.)
03	3L (Resin)
04	4L (Resin)
05	4L (Alum.)
08	8L (Iron)

Discharge Bore	
0	∅4
1	∅6
2	∅4 W/Pressure Gauge
3	∅6 W/Pressure Gauge

Air Inlet	
0	∅4
1	∅6

Special Request	
C	Add a Magnetic Filter (Available for 3L and above tanks only)
D	Add a Partition (Available for 3L, 4L resin tanks, and 8L iron tanks only)
PC	Add a NC Contact Pressure Switch
PO	Add a NO Contact Pressure Switch
SO	NO Contact Float Switch

◆ Dimensional Data

Tank Capacity	Tank Material	Length (mm)	Width (mm)	Height (mm)	Mounting Hole Distance (mm)	N.W. (kg)
2L	Resin	168	118	227	144	2.35
2L	Alum.	217	150	212	95x200	3.15
3L	Resin	231	166	222	205	2.94
4L	Resin	277	160	236	250	2.76
4L	Alum.	297	170	232	95x280	4.22
8L	Iron	355	201	232	95x338	7.32

◆ Technical Data

Pneumatic Pressure (kgf/cm ²)	4	5	6	7	8
Operating Pressure (kgf/cm ²)	14	18	23	28	33
Discharge Volume	0-8 cc/stroke (Adjustable)				
Air Inlet	∅4, ∅6 (Inner Thread M5)				
Discharge Bore	∅4, ∅6				
Float Switch	NC Contact (NO Contact on request)				
Pressure Switch	Optional (NC or NO Contact)				
Suitable Viscosity	Oil, 10-220 cSt@40°C				

◆ Related Products



P. 81

P. 82

P. 109

P. 111

P. 109

P. 120

P. 124

P. 123

P. 127

CEH Circulating Type Oil Electric Lubricator PLC



CEH-05-C-25-3-A

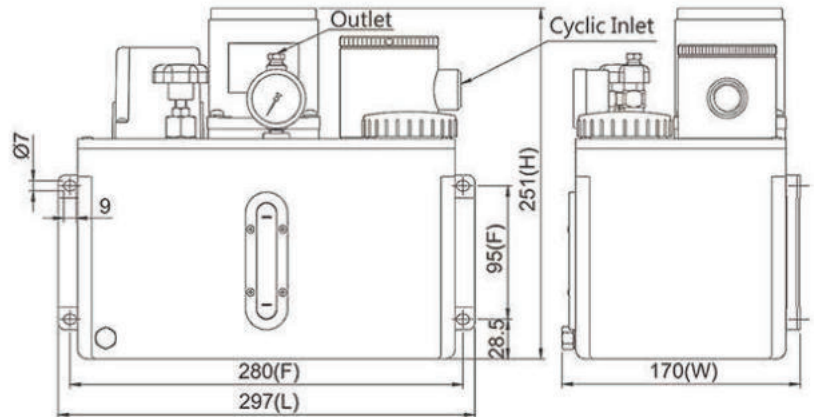

Dimensional Drawing of CEH-05-C-25-3-A

◆ Features

1. CEH has a cyclic inlet that allows the oil to return to the oil tank, which saves the oil consumption.
2. CEH has a magnetic filter inside the cyclic inlet that prevents iron filings from entering the oil tank to maintain the cleanness of the circulating oil.
3. The operation and interval time of CEH are controlled by PLC. CEH also can operate continuously without interval time.
4. The gear pump of CEH is made of special aluminum alloy and assembled with the induction motor to provide stable output pressure, low operating noise, and long service life.
5. CEH has a pressure-regulating valve that enables the user to adjust the operating pressure.
6. CEH has a NC float switch that detects the oil level automatically and sends signals when the oil level is low.
7. After installing CEH and connecting all oil pipes, let CEH continue running until oil fulfills all oil pipes. The lubricator is ready to use when the oil flows out to remove the air bubbles.

◆ Dimensional Data

Motor Power	Tank Capacity	Tank Material	Length (mm)	Width (mm)	Height (mm)	Mounting Hole Distance (mm)	N.W. (kg)
25W	4L	Aluminum	297	170	251	95x280	6.85
	8L	Iron	355	201	271	95x338	9.85
	12L	Iron	495	225	251	95x478	12.60
60W	8L	Iron	355	201	331	95x338	11.35
	12L	Iron	495	225	311	95x478	13.65

◆ Technical Data

Motor Power	25W			60W		
	1Ø110V	1Ø220V	Three Phase	1Ø110V	1Ø220V	Three Phase
Voltage	1Ø110V	1Ø220V	Three Phase	1Ø110V	1Ø220V	Three Phase
Ampere	0.6A	0.3A	0.3A	1.2A	0.6A	0.6A
Max. Discharge Volume	250cc/min			500cc/min		
Max. Operating Pressure	15kgf/cm ²			30kgf/cm ²		
Hertz	50/60Hz Compatible					
Discharge Bore	Ø4, Ø6					
Cyclic Inlet	PT1/2, PT3/4					
Float Switch	NC Contact (NO Contact on request)					
Suitable Viscosity	Oil, 32-68 cSt@40°C					

CEH Circulating Type Oil Electric Lubricator PLC

◆ Order Code

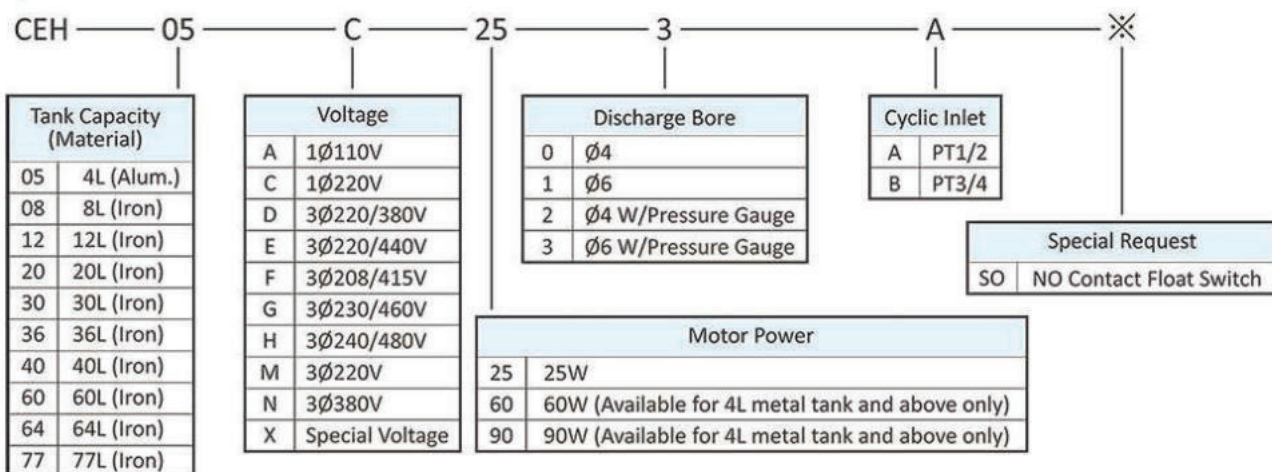

※ A standard dual-voltage motor is connected for low voltage. Please specify if you need it to be connected for high voltage when placing an order.

◆ Wiring Diagram

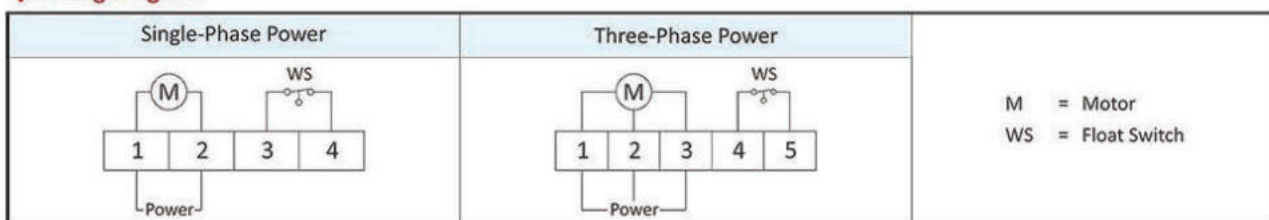

※ The motor shaft is marked with a red dot. When wiring the three-phase-voltage CEH, please note the motor should rotate anticlockwise. If the motor rotates clockwise, please switch the position of any two of the power wires and rewire them.

◆ Related Products



CEU Circulating Type Oil Electric Lubricator PLC



CEU-08-C-25-3-A

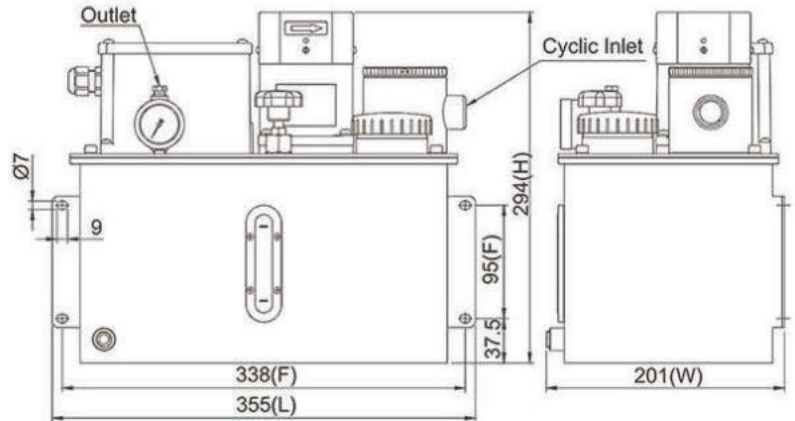

Dimensional Drawing of CEU-08-C-25-3-A

◆ Features

1. CEU has a cyclic inlet that allows the oil to return to the oil tank, which saves the oil consumption.
2. CEU has a magnetic filter inside the cyclic inlet that prevents iron filings from entering the oil tank to maintain the cleanness of the circulating oil.
3. The operation and interval time of CEU are controlled by PLC. CEU also can operate continuously without interval time.
4. The gear pump of CEU is made of special aluminum alloy and assembled with the induction motor to provide stable output pressure, low operating noise, and long service life.
5. The induction motor has a fan that reduces the temperature and prolongs the service life of CEU.
6. CEU has a pressure-regulating valve that enables the user to adjust the operating pressure.
7. CEU has a NC contact float switch that detects the oil level automatically and sends signals when the oil level is low.
8. CEU has a 1kgf/cm² socket pressure switch that detects the operating pressure automatically.
9. After installing CEU and connecting all oil pipes, let CEU continue running until oil fulfills all oil pipes. The lubricator is ready to use when the oil flows out to remove the air bubbles.

◆ Dimensional Data

Motor Power	Tank Capacity	Tank Material	Length (mm)	Width (mm)	Height (mm)	Mounting Hole Distance (mm)	N.W. (kg)
25W	8L	Iron	355	201	294	95x338	12.25
	20L	Iron	446	267	399	410x200	17.80
	64L	Iron	560	480	534	450x300	43.00
60W	8L	Iron	355	201	331	95x338	12.15
	20L	Iron	446	267	436	410x200	18.90
	64L	Iron	560	480	571	450x300	44.05

◆ Technical Data

Motor Power	25W			60W		
	1Ø110V	1Ø220V	Three Phase	1Ø110V	1Ø220V	Three Phase
Voltage	1Ø110V	1Ø220V	Three Phase	1Ø110V	1Ø220V	Three Phase
Ampere	0.6A	0.3A	0.3A	1.2A	0.6A	0.6A
Max. Discharge Volume	250cc/min			500cc/min		
Max. Operating Pressure	15kgf/cm ²			30kgf/cm ²		
Hertz	50/60Hz Compatible					
Discharge Bore	Ø4, Ø6					
Cyclic Inlet	PT1/2, PT3/4					
Float Switch	NC Contact (NO Contact on request)					
Pressure Switch	Optional (NC or NO Contact)					
Suitable Viscosity	Oil, 32-68 cSt@40°C					

CEU Circulating Type Oil Electric Lubricator PLC

◆ Order Code

CEU — 08 — C — 25 — 3 — A — ※

Tank Capacity (Material)	
08	8L (Iron)
12	12L (Iron)
20	20L (Iron)
30	30L (Iron)
36	36L (Iron)
40	40L (Iron)
60	60L (Iron)
64	64L (Iron)
77	77L (Iron)

Voltage	
A	1 ϕ 110V
C	1 ϕ 220V
D	3 ϕ 220/380V
E	3 ϕ 220/440V
F	3 ϕ 208/415V
G	3 ϕ 230/460V
H	3 ϕ 240/480V
M	3 ϕ 220V
N	3 ϕ 380V
X	Special Voltage

Motor Power	
25	25W
60	60W
90	90W

Discharge Bore	
0	ϕ 4
1	ϕ 6
2	ϕ 4 W/Pressure Gauge
3	ϕ 6 W/Pressure Gauge

Cyclic Inlet	
A	PT1/2
B	PT3/4

Special Request	
PO	NO Contact Pressure Switch
SO	NO Contact Float Switch

※ A standard dual-voltage motor is connected for low voltage. Please specify if you need it to be connected for high voltage when placing an order.

◆ Wiring Diagram

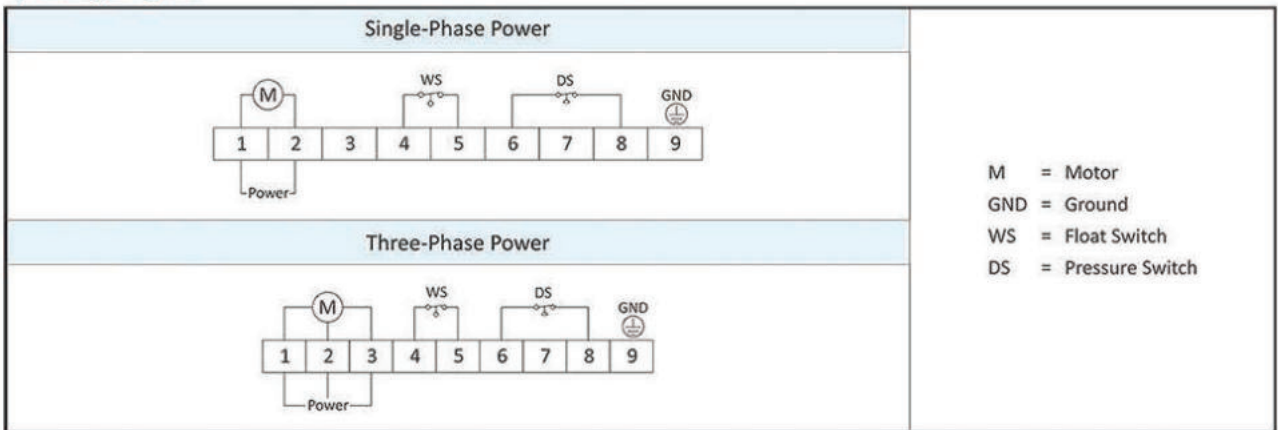

※ The motor shaft is marked with a red dot. When wiring the three-phase-voltage CEU, please note the motor should rotate anticlockwise. If the motor rotates clockwise, please switch the position of any two of the power wires and rewire them.

◆ Related Products



CLS Circulating Type Oil Electric Lubricator



CLS-10-36-D-2-3-C

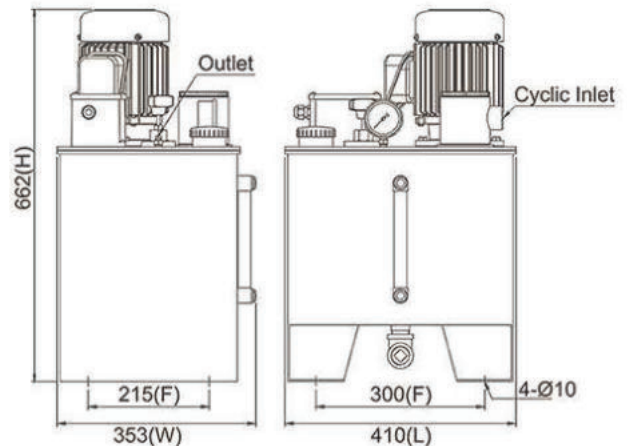

Dimensional Drawing of CLS-10-36-D-2-3-C

◆ Features

1. CLS has a cyclic inlet that allows the oil to return to the oil tank, which saves the oil consumption.
2. CLS has a magnetic filter inside the cyclic inlet that prevents iron filings from entering the oil tank to maintain the cleanness of the circulating oil.
3. The operation and interval time of CLS are controlled by PLC. CLS also can operate continuously without interval time.
4. The gear pump of CLS is made of special aluminum alloy and assembled with the 1/2HP or 1HP motor to provide stable output pressure, low operating noise, and long service life.
5. CLS has a pressure-regulating valve that enables the user to adjust the operating pressure.
6. CLS has a NC contact float switch that detects the oil level automatically and sends signals when the oil level is low.
7. CLS has a 1kgf/cm² socket pressure switch that detects the operating pressure automatically.
8. After installing CLS and connecting all oil pipes, let CLS continue running until oil fulfills all oil pipes. The lubricator is ready to use when the oil flows out to remove the air bubbles.

◆ Dimensional Data

Model	Tank Capacity	Tank Material	Length (mm)	Width (mm)	Height (mm)	Mounting Hole Distance (mm)	N.W. (kg)
CLS-10	36L	Iron	410	353	662	300x215	46.3
CLS-30	64L	Iron	560	480	662	450x300	52.5
CLS-50	77L	Iron	610	480	692	500x300	75.5

◆ Technical Data

Motor Power (Number of Poles)	1/2HP, 1HP (4P)		
Voltage	1Ø110V, 1Ø220V, Three Phase		
Max. Discharge Volume	CLS-10: 1.5 L/min	CLS-30: 3.0 L/min	CLS-50: 4.5 L/min
Max. Operating Pressure	15kgf/cm ²		
Discharge Bore	Ø4, Ø6		
Cyclic Inlet	PT3/4, PT1		
Float Switch	NC Contact (NO Contact on request)		
Pressure Switch	NC Contact (NO Contact on request)		
Suitable Viscosity	Oil, 32-100 cSt@40°C		

◆ Order Code

CLS — 10 — 30 — D — 2 — 3 — C — ※

Discharge Volume	
10	1.5 L/min
30	3.0 L/min
50	4.5 L/min

Tank Capacity (Material)	
30	30L (Iron)
36	36L (Iron)
40	40L (Iron)
60	60L (Iron)
64	64L (Iron)
77	77L (Iron)
100	100L (Iron)
130	130L (Iron)
150	150L (Iron)
204	204L (Iron)

Voltage	
A	1Ø110V
C	1Ø220V
D	3Ø220/380V
E	3Ø220/440V
F	3Ø208/415V
G	3Ø230/460V
H	3Ø240/480V
M	3Ø220V
N	3Ø380V
X	Special Voltage

Motor Power	
2	1/2HP
4	1HP

Discharge Bore (PT1/4)	
2	Ø4 W/Pressure Gauge
3	Ø6 W/Pressure Gauge

Cyclic Inlet	
B	PT3/4
C	PT1

Special Request	
PO	NO Contact Pressure Switch
SO	NO Contact Float Switch

※ A standard dual-voltage motor is connected for low voltage. Please specify if you need it to be connected for high voltage when placing an order.

◆ Related Products



CLSA / CLSB Circulating Type Oil Electric Lubricator PLC



CLSA-20-10-D-1-3-B

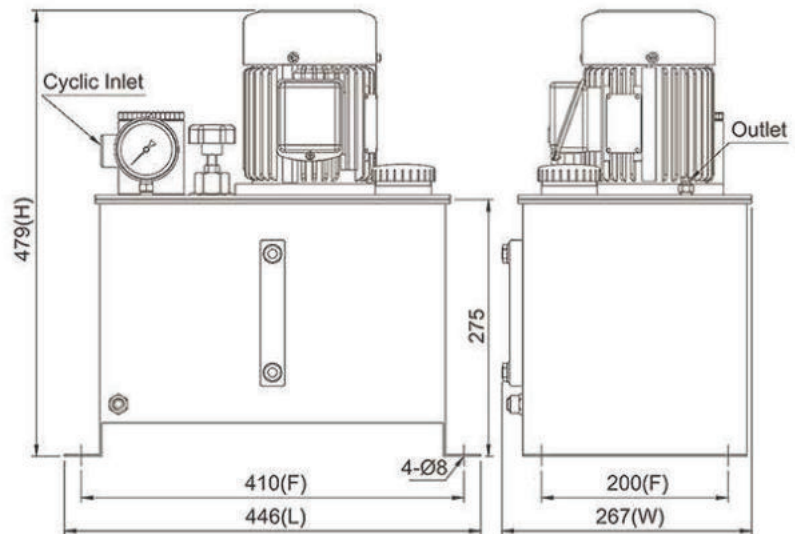

Dimensional Drawing of CLSA-20-10-D-1-3-B



CLSB-20-10-D-1-3-B

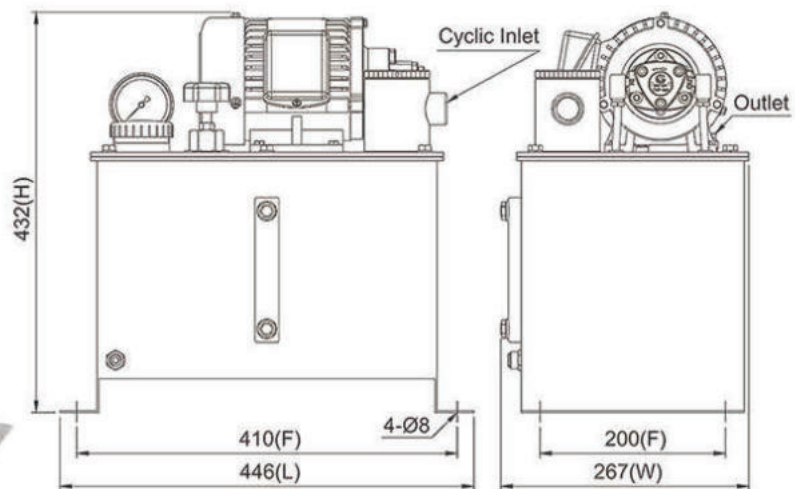

Dimensional Drawing of CLSB-20-10-D-1-3-B

◆ Features

1. CLSA has a vertical 1/4HP cast iron frame motor, and CLSB has a horizontal one.
2. CLSA and CLSB have cyclic inlets that allow oil to return to the oil tank to save the oil consumption.
3. CLSA and CLSB have magnetic filters inside the cyclic inlets that prevent iron filings from entering the oil tank to maintain the cleanness of the circulating oil.
4. The operation and interval time of CLSA and CLSB are controlled by PLC. Both CLSA and CLSB also can operate continuously without interval time.
5. The rotary oil pumps of CLSA and CLSB are made of special aluminum alloy and assembled with the 1/4HP motor to provide stable output pressure, low operating noise, and long service life.
6. CLSA and CLSB have pressure-regulating valves that enable the user to adjust the operating pressure.
7. CLSA and CLSB have NC contact float switches that detect the oil level automatically and send signals when the oil level is low.
8. After installing the lubricator and connecting all oil pipes, let the lubricator continue running until oil fulfills all oil pipes. The lubricator is ready to use when the oil flows out to remove the air bubbles.

CLSA / CLSB Circulating Type Oil Electric Lubricator PLC

◆ Dimensional Data

Model	Tank Capacity	Tank Material	Length (mm)	Width (mm)	Height (mm)	Mounting Hole Distance (mm)	N.W. (kg)
CLSA	20L	Iron	446	267	479	410x200	26.7
	36L	Iron	410	353	614	300x215	38.8
	64L	Iron	560	480	614	450x300	52.2
CLSB	20L	Iron	446	267	432	410x200	26.7
	36L	Iron	410	353	567	300x215	38.8
	64L	Iron	560	480	567	450x300	52.2

◆ Technical Data

Motor Power (Number of Poles)	1/4HP (4P)			
Voltage	1Ø110V, 1Ø220V, Three Phase			
Rotary Oil Pump	CYP-10A	CYP-11A	CYP-12A	CYP-13A
Max. Discharge Volume	1.1-1.4 L/min	2.2-2.7 L/min	3.7-4.5 L/min	6.5-7.9 L/min
Max. Operating Pressure	5kgf/cm ²			
Discharge Bore	Ø4, Ø6			
Cyclic Inlet	PT1/2, PT3/4			
Float Switch	NC Contact (NO Contact on request)			
Suitable Viscosity	Oil, 32-68 cSt@40°C			

◆ Order Code

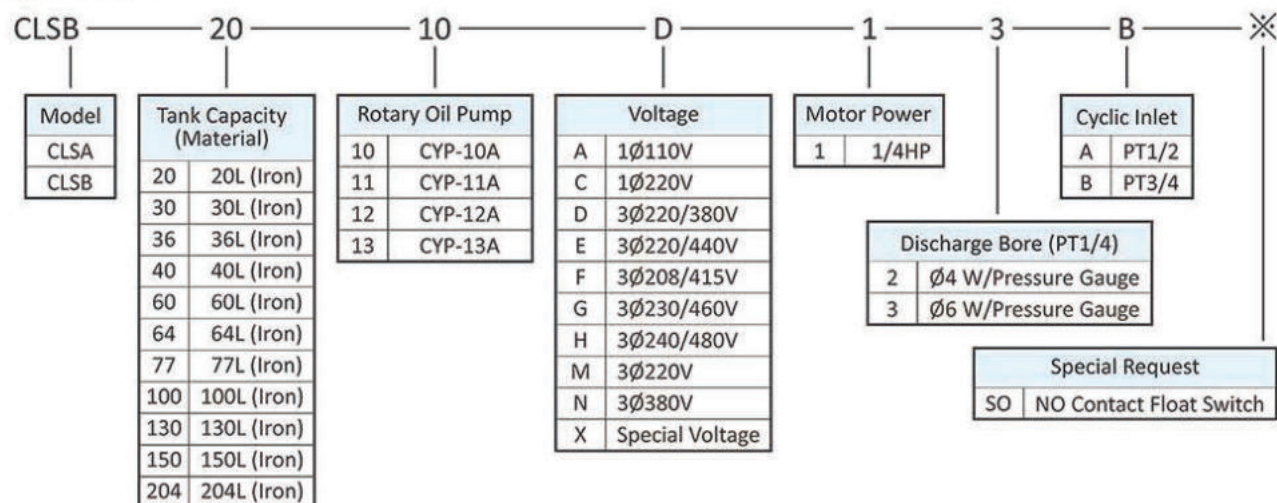

※ A standard dual-voltage motor is connected for low voltage. Please specify if you need it to be connected for high voltage when placing an order.

◆ Related Products

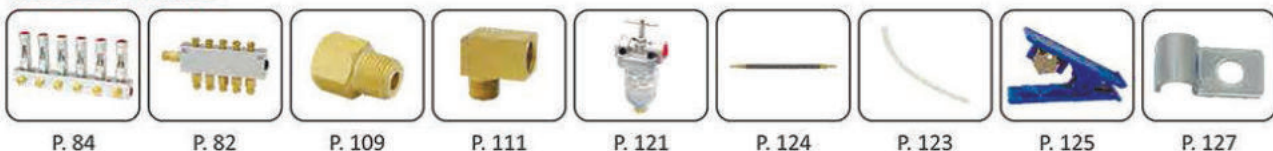

P. 84

P. 82

P. 109

P. 111

P. 121

P. 124

P. 123

P. 125

P. 127

CLSS Small-Size Circulating Type Oil Electric Lubricator with Cooler PLC



CLSS-08-M-90-A-A

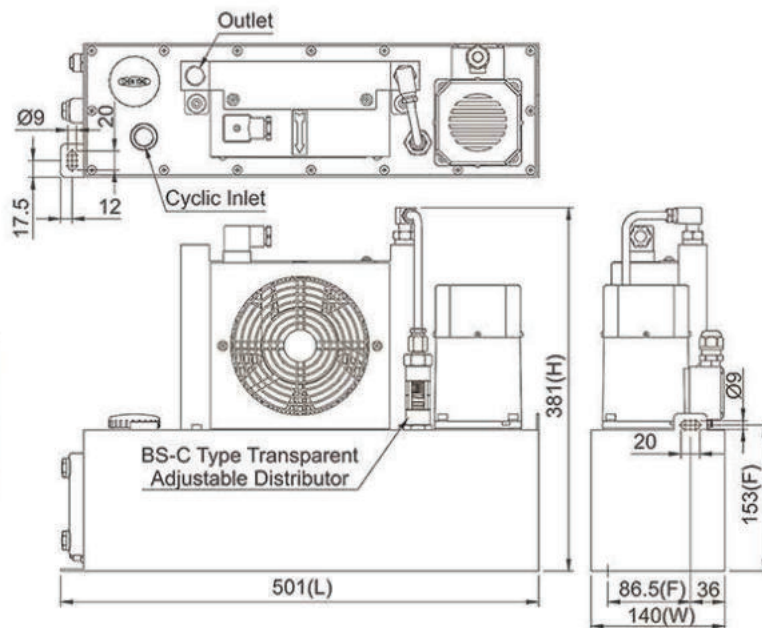

Dimensional Drawing of CLSS-08-M-90-A-A

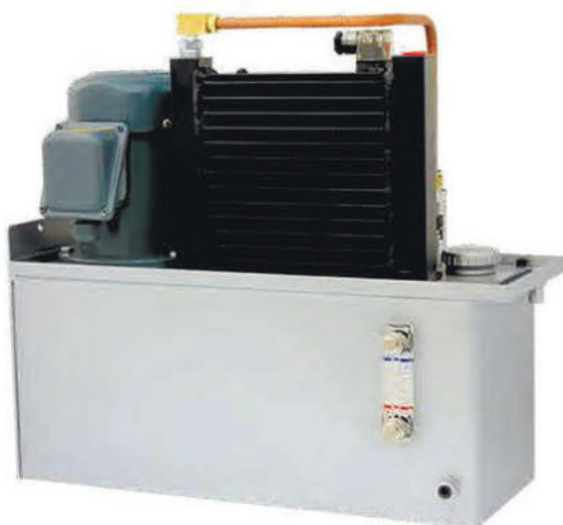

CLSS-14-13-1-D-A-A

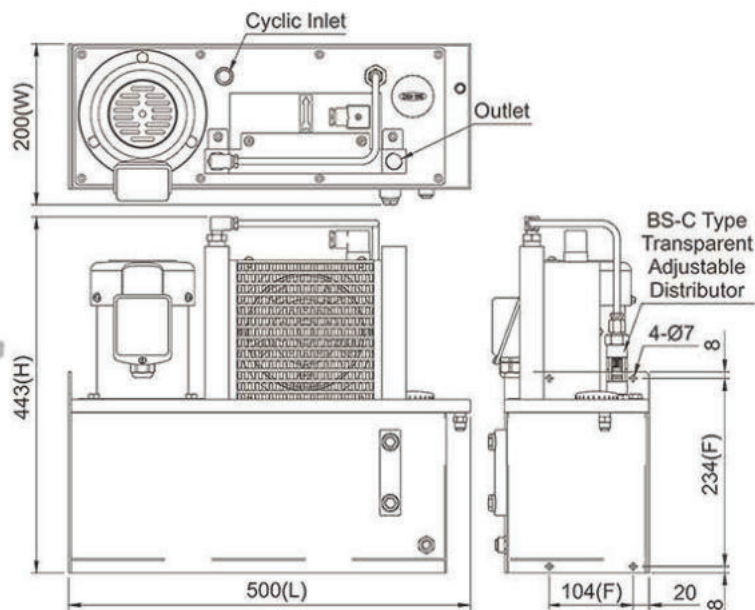

Dimensional Drawing of CLSS-14-13-1-D-A-A

◆ Features

1. CLSS is a small-size circulating lubricator with a cooler that is suitable for the machine with limited space. There are two models available, CLSS-08 with an 8-liter oil tank and CLSS-14 with a 14-liter tank.
2. The operation and interval time of CLSS are controlled by PLC. Both CLSS-08 and CLSS-14 also can operate continuously without interval time.
3. CLSS has a highly efficient air cooler that reduces the oil temperature to room temperature plus 10°C.
4. CLSS has a cyclic inlet that allows the oil to return to the oil tank, which saves the oil consumption.
5. CLSS has a BS-C transparent distributor that enables the user to check if the oil flows into the cooler normally. A reed switch can be added to BS-C on request to detect the oil flow automatically.
6. CLSS-08 has a gear pump and a 90W induction motor. The discharge volume is 1.8L/min.
7. CLSS-14 has a rotary oil pump and a 1/4HP steel plate frame vertical motor with a connector. According to the discharge volume of the rotary oil pump, four types of choices are available upon request.
8. Please install CLSS in a clean and well-ventilated place. Please reserve space at least half of the fan diameter of the air cooler at its air inlet and outlet to allow the air to flow through smoothly.
9. Please clean the air cooler regularly to prevent the buildup of dust on its surface that affects the performance it.
10. After installing CLSS and connecting all oil pipes, let CLSS continue running until oil fulfills all oil pipes. The lubricator is ready to use when the oil flows out to remove the air bubbles.

CLSS Small-Size Circulating Type Oil Electric Lubricator with Cooler PLC

◆ Dimensional Data

Model	Tank Capacity	Tank Material	Length (mm)	Width (mm)	Height (mm)	Mounting Hole Distance (mm)	N.W. (kg)
CLSS-08	8L	Iron	501	140	381	153x86.5	14.9
CLSS-14	14L	Iron	500	200	443	234x104.0	24.0

◆ Technical Data (CLSS Lubricator)

Model	CLSS-08		CLSS-14			
Type of Motor	90W Induction Motor		1/4HP Steel Plate Frame Vertical Motor with a Connector			
Number of Poles	-		4P			
Voltage	3 ϕ 220V	3 ϕ 380V	1 ϕ 110V, 1 ϕ 220V, Three Phase			
Ampere	0.6A	0.3A	-			
Hertz	50/60Hz Compatible		-			
Rotary Oil Pump	-		CYP-10A	CYP-11A	CYP-12A	CYP-13A
Max. Discharge Volume	1.8 L/min		1.1-1.4 L/min	2.2-2.7 L/min	3.7-4.5 L/min	6.5-7.9 L/min
Max. Operating Pressure	5kgf/cm ²		5kgf/cm ²			
Discharge Bore	PT1/2		PT1/2			
Cyclic Inlet	PT1/2, PT3/4		PT1/2, PT3/4			
Reed Switch	Optional (NC or NO Contact)		Optional (NC or NO Contact)			
Suitable Viscosity	Oil, 32-68 cSt@40°C		Oil, 32-68 cSt@40°C			

◆ Technical Data (Highly Efficient Air Cooler) ※ Data origin is the catalogue of the manufacturer.

Air Cooler			Motor with Fan					
Suitable Fluid	Max. Pressure	Heat Exchange	Pressure Loss	Voltage	Hertz	Input Power	Rotational Speed	Ampere
Mineral Oil	1.0MPa	3L/hour, 565kcal/hour (at 20°C above room temperature)	0.1 bar (3L/min)	1 ϕ 230V	50Hz	45W	2850min ⁻¹	0.27A
					60Hz	37W	3450min ⁻¹	0.23A

◆ Order Code (CLSS-08)

CLSS — 08 — M — 90 — A — A — ※

Tank Capacity (Material)	Voltage	Motor Power	Discharge Bore	Cyclic Inlet	Special Request
08 8L (Iron)	M 3 ϕ 220V N 3 ϕ 380V X Special Voltage	90 90W	A PT1/2	A PT1/2 B PT3/4	TC Add a NC Contact Reed Switch TO Add a NO Contact Reed Switch

※ The 90W motor of CLSS-08 has a terminal box. Due to limited wiring space, only three phase single voltage is available.

◆ Order Code (CLSS-14)

CLSS — 14 — 13 — 1 — D — A — A — ※

Tank Capacity (Material)	Motor Power	Voltage	Discharge Bore	Special Request
14 14L (Iron)	1 1/4HP	A 1 ϕ 110V C 1 ϕ 220V D 3 ϕ 220/380V E 3 ϕ 220/440V F 3 ϕ 208/415V G 3 ϕ 230/460V H 3 ϕ 240/480V M 3 ϕ 220V N 3 ϕ 380V X Special Voltage	A PT1/2	TC Add a NC Contact Reed Switch TO Add a NO Contact Reed Switch

Rotary Oil Pump
10 CYP-10A
11 CYP-11A
12 CYP-12A
13 CYP-13A

Cyclic Inlet
A PT1/2
B PT3/4

※ A standard dual-voltage motor is connected for low voltage. Please specify if you need it to be connected for high voltage when placing an order.

◆ Related Products

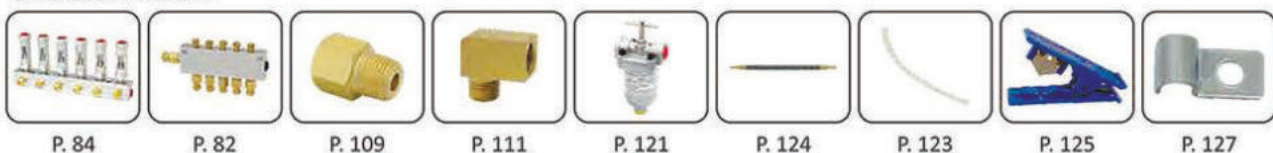

CLST Circulating Type Oil Electric Lubricator with Cooler PLC



CLST-20-10-D-1-3-B

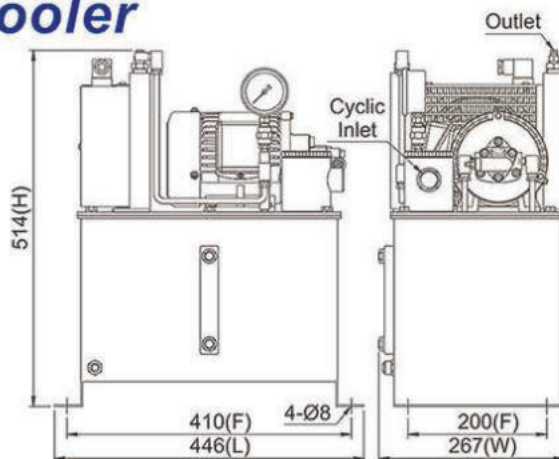

Dimensional Drawing of CLST-20-10-D-1-3-B

◆ Features

1. CLST has a highly efficient air cooler that reduces the oil temperature to room temperature plus 10°C.
2. CLST has a cyclic inlet that allows the oil to return to the oil tank, which saves the consumption of oil.
3. CLST has a magnetic filter inside the cyclic inlet that prevents iron filings from entering the oil tank to maintain the cleanness of the circulating oil.
4. The operation and interval time of CLST are controlled by PLC. CLST also can operate continuously without interval time.
5. The rotary oil pump of CLST is made of special aluminum alloy and assembled with the 1/4HP motor to provide stable output pressure, low operating noise, and long service life.
6. CLST has a pressure-regulating valve that enables the user to adjust the operating pressure.
7. CLST has a NC contact float switch that detects the oil level automatically and sends signals when the oil level is low.
8. After installing CLST and connecting all oil pipes, let CLST continue running until oil fulfills all oil pipes. The lubricator is ready to use when the oil flows out to remove the air bubbles.

◆ Dimensional Data

Tank Capacity	Tank Material	Length (mm)	Width (mm)	Height (mm)	Mounting Hole Distance (mm)	N.W. (kg)
20L	Iron	446	267	514	410x200	29.5
36L	Iron	410	353	649	300x215	41.5
64L	Iron	560	480	649	450x300	54.4

◆ Technical Data

Motor Power (Number of Poles)	1/4HP (4P)			
Voltage	1Ø110V, 1Ø220V, Three Phase			
Max. Discharge Volume	CYP-10A: 1.1-1.4L/min	CYP-11A: 2.2-2.7L/min	CYP-12A: 3.7-4.5L/min	CYP-13A: 6.5-7.5L/min
Max. Operating Pressure	5kgf/cm ²			
Discharge Bore	Ø4, Ø6			
Cyclic Inlet	PT1/2, PT3/4			
Float Switch	NC Contact (NO Contact on request)			
Suitable Viscosity	Oil, 32-68 cSt@40°C			

◆ Order Code

CLST — 20 — 10 — D — 1 — 3 — B — ※

Tank Capacity (Material)		Rotary Oil Pump		Voltage		Motor Power		Cyclic Inlet		Discharge Bore (PT3/8)		Special Request	
20	20L (Iron)	10	CYP-10A	A	1Ø110V	1	1/4HP	A	PT1/2	2	Ø4 W/Pressure Gauge	SO	NO Contact Float Switch
30	30L (Iron)	11	CYP-11A	C	1Ø220V			B	PT3/4	3	Ø6 W/Pressure Gauge	M	Customized Motor Power
36	36L (Iron)	12	CYP-12A	D	3Ø220/380V								
40	40L (Iron)	13	CYP-13A	E	3Ø220/440V								
60	60L (Iron)			F	3Ø208/415V								
64	64L (Iron)			G	3Ø230/460V								
77	77L (Iron)			H	3Ø240/480V								
100	100L (Iron)			M	3Ø220V								
130	130L (Iron)			N	3Ø380V								
150	150L (Iron)			X	Special Voltage								
204	204L (Iron)												

※ A standard dual-voltage motor is connected for low voltage. Please specify if you need it to be connected for high voltage when placing an order.

◆ Related Products

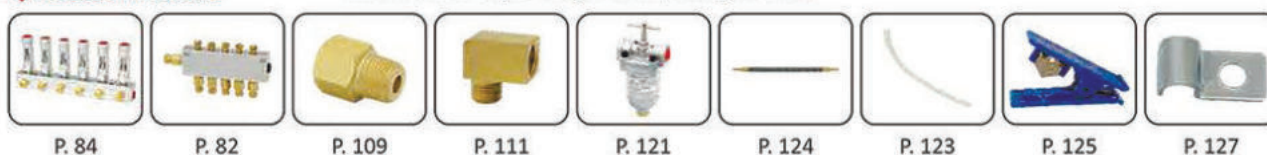

CEF Circulating Type Oil Electric Lubricator Timer



CEF-05-2-C-25-3-A

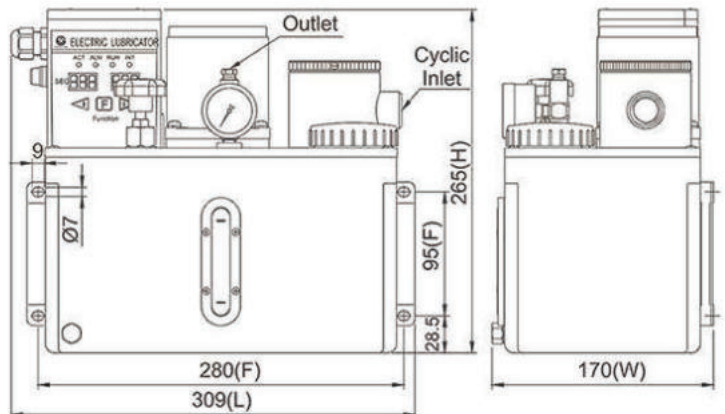

Dimensional Drawing of CEF-05-2-C-25-3-A

◆ Features

1. CEF has a cyclic inlet that allows the oil to return to the oil tank, which saves the oil consumption.
2. CEF has a magnetic filter inside the cyclic inlet that prevents iron filings from flowing into the oil tank to maintain the cleanness of the circulating oil.
3. CEF has a timer that controls its operation and interval time. The control box has four indicators, operation (ACT), alarm (ALM), immediate lubrication (RUN), and interval (INT).
4. The control box has a build-in buzzer that sends an alarm sound when the oil level is low.
5. The gear pump of CEF is made of special aluminum alloy and assembled with the induction motor to provide stable output pressure, low operating noise, and long service life.
6. CEF has a pressure-regulating valve that enables the user to adjust the operating pressure.
7. CEF has a NC contact float switch that detects the oil level automatically and sends signals when the oil level is low.
8. CEF has a feed-oil button (F button), which can be used as manual oil feeding for less than 3 minutes to avoid overloading the motor.
9. After installing CEF and connecting all oil pipes, let CEF continue running until oil fulfills all oil pipes. The lubricator is ready to use when the oil flows out to remove the air bubbles.

◆ Order Code

CEF — 05 — 2 — C — 25 — 3 — A

Tank Capacity (Material)		Voltage		Cyclic Inlet	
05	4L (Alum.)	A	110V	A	PT1/2
08	8L (Iron)	C	220V	B	PT3/4
12	12L (Iron)	ACT x INT		Discharge Bore	
20	20L (Iron)				
30	30L (Iron)	2	sec x min	1	∅6
36	36L (Iron)	Motor Power		2	∅4
40	40L (Iron)			3	∅6
60	60L (Iron)			W/Pressure Gauge	
64	64L (Iron)	25		25W	
77	77L (Iron)	60		60W (Available for 8L tank and above only)	
		90		90W (Available for 8L tank and above only)	

◆ Dimensional Data

Motor Power	Tank Capacity & Material	Length (mm)	Width (mm)	Height (mm)	Mounting Hole Distance (mm)	N.W. (kg)
25W	4L Alum.	309	170	265	95x280	7.50
	8L Iron	355	201	285	95x338	10.10
	12L Iron	495	225	265	95x478	12.40
60W	8L Iron	355	201	331	95x338	11.15
	12L Iron	495	225	311	95x478	13.45

◆ Technical Data

Operation Time	1-999 sec			
Interval Time	1-999 sec, 1-999 min			
Motor Power	25W		60W	
Voltage	110V	220V	110V	220V
Ampere	0.6A	0.3A	1.2A	0.6A
Hertz	50/60Hz Compatible			
Discharge Bore	∅4, ∅6			
Cyclic Inlet	PT1/2, PT3/4			
Float Switch	NC Contact			
Suitable Viscosity	Oil, 32-68 cSt@40°C			

◆ Wiring Diagram

Abnormal Output			Ground	Power
NO(A)	NC(B)	COM	GND(P.E)	POWER
⊕	⊕	⊕	⊕	⊕ ⊕

◆ Related Products



P. 81



P. 82



P. 120



P. 123

CEN24 Horizontal / CEN25 Vertical Oil-Mist Type Electric Lubricator

PLC



CEN24-03-C-25-3

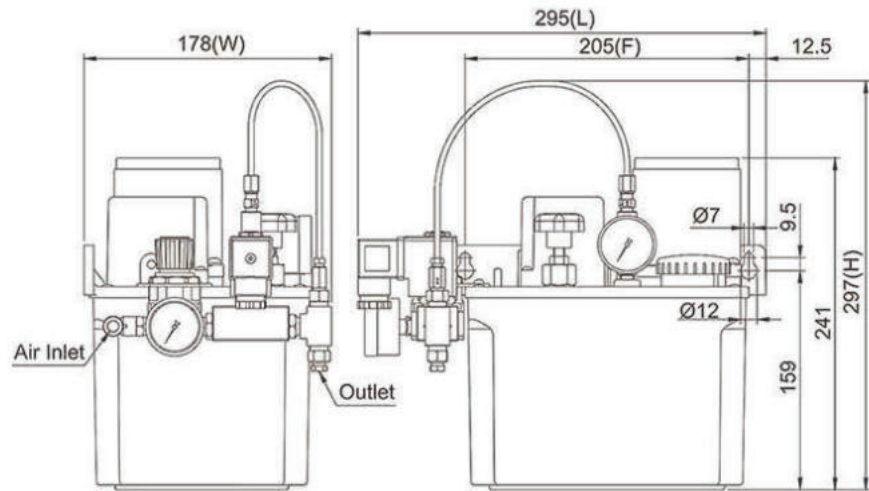

Dimensional Drawing of CEN24-03-C-25-3



CEN25-03-C-25-3

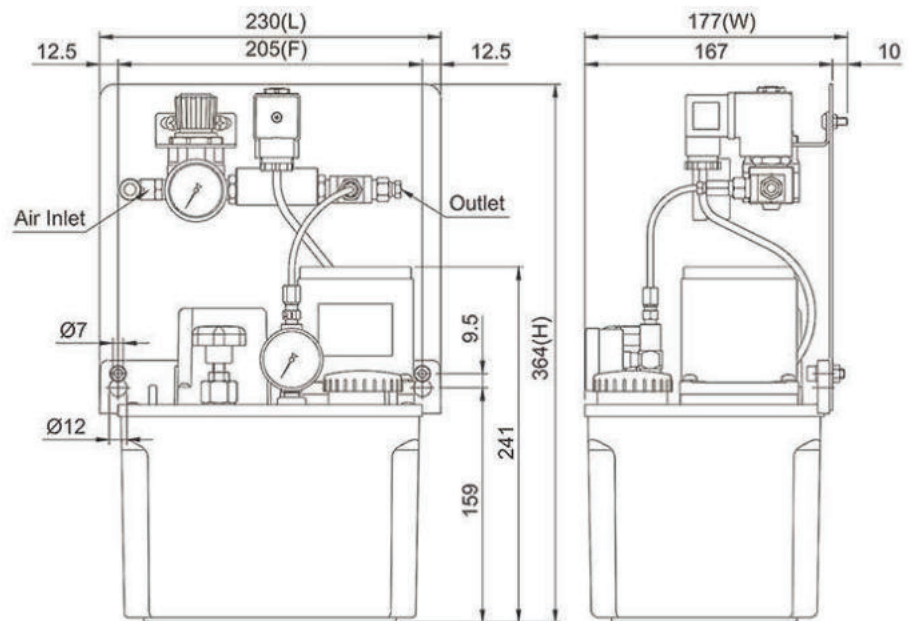

Dimensional Drawing of CEN25-03-C-25-3

◆ Features

1. CEN24 and CEN25 have solenoid valves to control the pneumatic supply. The solenoid valve installed on the left side is CEN24 and on the top is CEN25.
2. The operation and interval time are controlled by PLC.
3. CEN24 and CEN25 have pressure gauges that enable the users to check the operating pressure easily.
4. CEN24 and CEN25 have NC contact float switches that detect the oil level automatically and sends signals when the oil level is low.
5. CEN24 and CEN25 have pressure-regulating valves that enable the users to adjust the operating pressure. Turn the pressure-regulating valve clockwise to increase the discharge volume and turn it anticlockwise to decrease the discharge volume.
6. CEN24 and CEN25 have air-regulating valves that enable the users to adjust the air volume upon their demands.
7. When the power of CEN24 and CEN25 is off, the pneumatic pressure and output power will be off simultaneously for safety concerns.
8. CEN24 and CEN25 can cool down the lubrication area and filter out the wear particles from friction points to reduce mechanical wear and prolong the machine's service life during lubrication process.
9. Each lubrication point should be with an individual oil-mist lubricator for better lubrication results.

CEN24 Horizontal / CEN25 Vertical PLC Oil-Mist Type Electric Lubricator

◆ Dimensional Data

Model	Tank Capacity	Tank Material	Length (mm)	Width (mm)	Height (mm)	Mounting Hole Distance (mm)	N.W. (kg)
CEN24	3L	Resin	295	178	297	205	5.40
	4L	Resin	353	185	308	250	6.00
CEN25	3L	Resin	230	177	363	205	6.36
	4L	Resin	275	177	377	250	6.90

◆ Technical Data

Motor Power	25W	
Voltage	110V	220V
Ampere	0.6A	0.3A
Max. Discharge Volume	200cc/min	
Max. Operating Pressure	15kgf/cm ²	
Hertz	50/60Hz Compatible	
Discharge Bore	∅4, ∅6	
Float Switch	NC Contact (NO Contact on request)	
Suitable Viscosity	Oil, 32-68 cSt@40°C	

◆ Wiring Diagram



◆ Order Code

CEN24	03	C	25	3	※																
<table border="1" style="width: 100%; border-collapse: collapse;"> <thead> <tr><th>Model</th></tr> </thead> <tbody> <tr><td>24 Horizontal Type</td></tr> <tr><td>25 Vertical Type</td></tr> </tbody> </table>	Model	24 Horizontal Type	25 Vertical Type	<table border="1" style="width: 100%; border-collapse: collapse;"> <thead> <tr><th>Tank Capacity (Material)</th></tr> </thead> <tbody> <tr><td>03 3L (Resin)</td></tr> <tr><td>04 4L (Resin)</td></tr> </tbody> </table>	Tank Capacity (Material)	03 3L (Resin)	04 4L (Resin)	<table border="1" style="width: 100%; border-collapse: collapse;"> <thead> <tr><th>Voltage</th></tr> </thead> <tbody> <tr><td>A 110V</td></tr> <tr><td>C 220V</td></tr> </tbody> </table>	Voltage	A 110V	C 220V	<table border="1" style="width: 100%; border-collapse: collapse;"> <thead> <tr><th>Motor Power</th></tr> </thead> <tbody> <tr><td>25 25W</td></tr> </tbody> </table>	Motor Power	25 25W	<table border="1" style="width: 100%; border-collapse: collapse;"> <thead> <tr><th>Discharge Bore</th></tr> </thead> <tbody> <tr><td>2 ∅4 W/Pressure Gauge</td></tr> <tr><td>3 ∅6 W/Pressure Gauge</td></tr> </tbody> </table>	Discharge Bore	2 ∅4 W/Pressure Gauge	3 ∅6 W/Pressure Gauge	<table border="1" style="width: 100%; border-collapse: collapse;"> <thead> <tr><th>Special Request</th></tr> </thead> <tbody> <tr><td>SO NO Contact Float Switch</td></tr> </tbody> </table>	Special Request	SO NO Contact Float Switch
Model																					
24 Horizontal Type																					
25 Vertical Type																					
Tank Capacity (Material)																					
03 3L (Resin)																					
04 4L (Resin)																					
Voltage																					
A 110V																					
C 220V																					
Motor Power																					
25 25W																					
Discharge Bore																					
2 ∅4 W/Pressure Gauge																					
3 ∅6 W/Pressure Gauge																					
Special Request																					
SO NO Contact Float Switch																					

◆ Related Products



CEN22 Horizontal / CEN23 Vertical Oil-Mist Type Electric Lubricator

Timer



CEN22-03-1-C-25-3

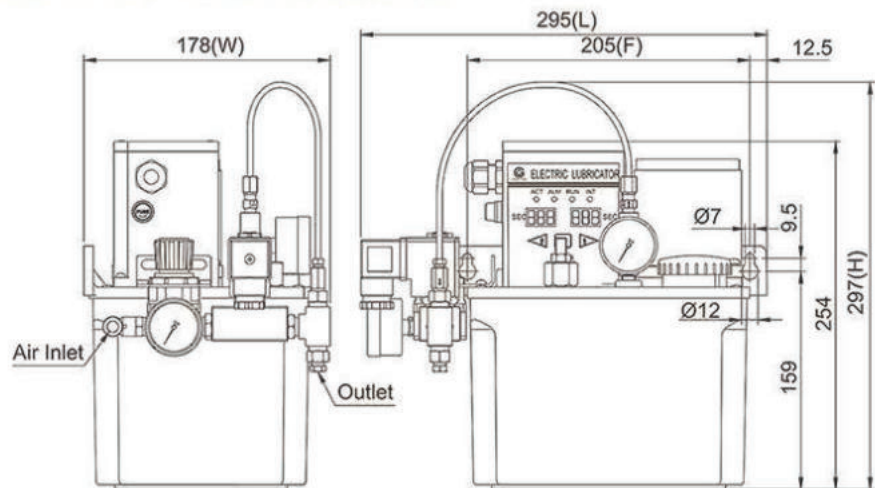

Dimensional Drawing of CEN22-03-1-C-25-3



CEN23-03-1-C-25-3

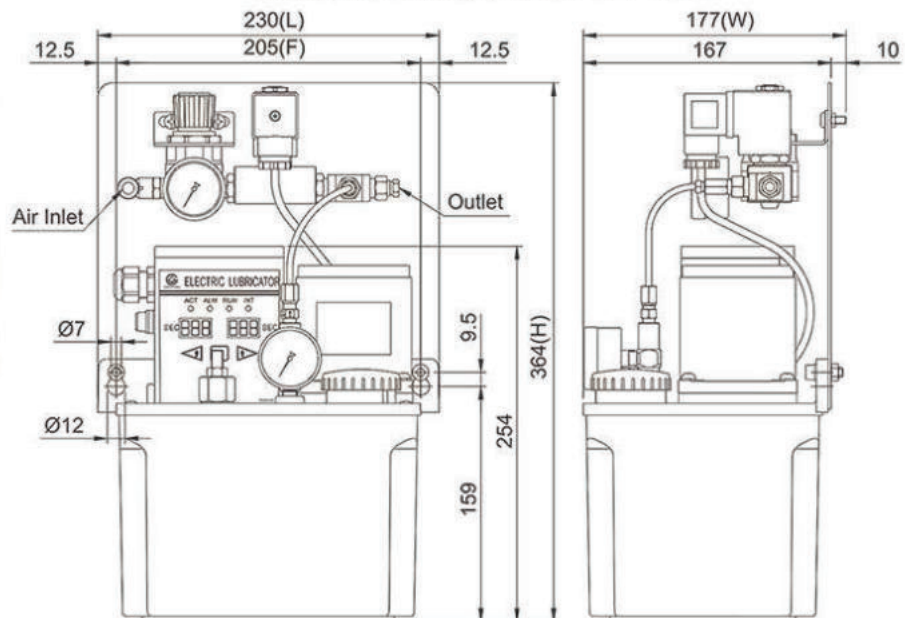

Dimensional Drawing of CEN23-03-1-C-25-3

◆ Features

1. CEN22 and CEN23 have solenoid valves to control the pneumatic supply. The solenoid valve is on the left side of CEN22 and on the top of CEN23.
2. CEN22 and CEN23 have timers that control the operation and interval time. The control box has a built-in buzzer that sends an alarm sound when the oil level is low. The control box also has four indicators, operation (ACT), alarm (ALM), immediate lubrication (RUN), and interval (INT).
3. CEN22 and CEN23 can memorize the set value of operation time and interval time.
4. There are two operation modes after the power of CEN22 and CEN23 is on. The standard mode is turn-on-interval.
 - Turn-on-feeding: Operation time starts first after the power is on.
 - Turn-on-interval: Interval time starts first after the power is on.
5. Turn-on-interval model has a memory function. If the power is suddenly off during the interval time, CEN22 and CEN23 will continue to operate from the remaining interval time after restarting, which can effectively avoid over-lubrication.
6. CEN22 and CEN23 have pressure gauges that enable the user to check the operating pressure easily.
7. CEN22 and CEN23 have NC contact float switches that detect the oil level automatically and send signals when the oil levels are low.
8. CEN22 and CEN23 have pressure-regulating valves that enable the user to adjust the operating pressure. Turn the valve clockwise to increase the discharge volume and turn it anticlockwise to decrease the discharge volume.
9. CEN22 and CEN23 have air-regulating valves that enable the users to adjust the air volume upon the need.
10. CEN22 and CEN23 have feed-oil buttons (F button), which can be used as manual oil feeding for less than 3 minutes to avoid overloading the motor.
11. When the power of CEN22 and CEN23 is turned off, the pneumatic pressure and output power will be turned off simultaneously for safety concerns.
10. CEN22 and CEN23 can cool down the lubrication area and filter out the wear particles from friction points to reduce mechanical wear and prolong machine's service life during lubrication process.
12. Each lubrication point should be with an individual oil-mist lubricator for better results.

CEN22 Horizontal / CEN23 Vertical Oil-Mist Type Electric Lubricator

Timer

◆ Dimensional Data

Model	Tank Capacity	Tank Material	Length (mm)	Width (mm)	Height (mm)	Mounting Hole Distance (mm)	N.W. (kg)
CEN22	3L	Resin	295	178	297	205	5.60
	4L	Resin	355	188	337	250	6.20
CEN23	3L	Resin	230	177	364	205	6.50
	4L	Resin	277	174	377	250	7.10

◆ Technical Data

Operation Time	1-999 sec	
Interval Time	1-999 sec, 1-999 min	
Motor Power	25W	
Voltage	110V	220V
Ampere	0.6A	0.3A
Max. Discharge Volume	200cc/min	
Max. Operating Pressure	15kgf/cm ²	
Hertz	50/60Hz Compatible	
Discharge Bore	ø4, ø6	
Float Switch	NC Contact	
Suitable Viscosity	Oil, 32-68 cSt@40°C	

◆ Wiring Diagram

Abnormal Output			Ground	Power	
NO(A)	NC(B)	COM	GND(P.E)	POWER	
⊕	⊕	⊕	⊕	⊕	⊕

◆ Order Code

CEN22 — 03 — 1 — C — 25 — 3 — ※

Model	Tank Capacity (Material)	ACT x INT	Voltage	Motor Power	Discharge Bore
22 Horizontal Type	03 3L (Resin)	1 sec x sec	A 110V	25 25W	2 ø4 W/Pressure Gauge
23 Vertical Type	04 4L (Resin)	2 sec x min	C 220V		3 ø6 W/Pressure Gauge

Special Request	
1	Turn-on-feeding Operation Mode

◆ Related Products



P. 100

P. 100

P. 109

P. 111

P. 125

P. 124

P. 123

P. 125

P. 127

COM Oil-Mist Type Pneumatic Lubricator



COM-01

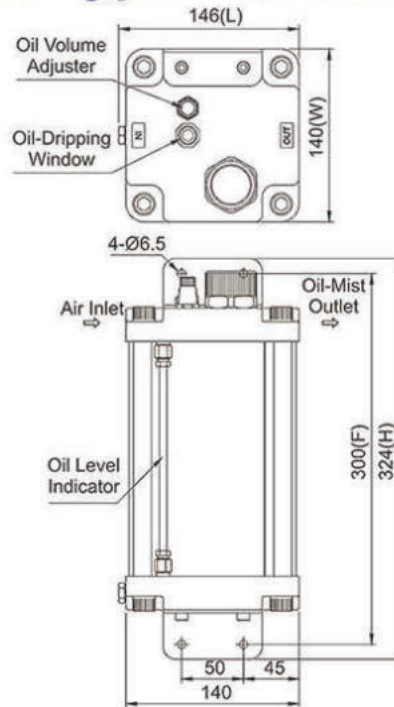

Dimensional Drawing of COM-01

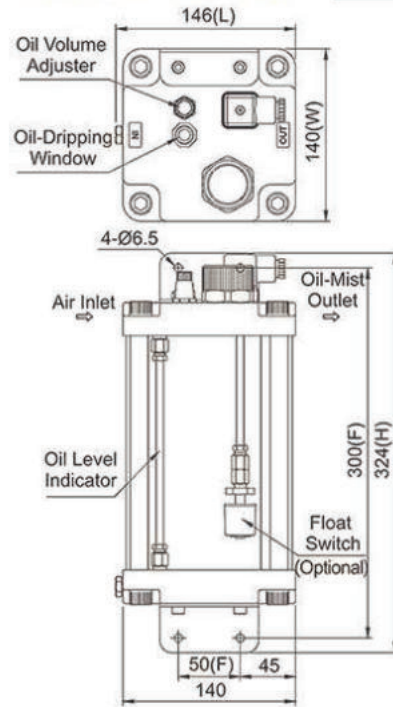

Dimensional Drawing of COM-01-SC



OB Spray Gun

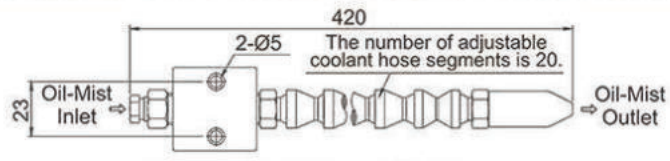

Dimensional Drawing of OB Spray Gun

◆ Features

1. With its superior oil-mist mixture, COM is suitable for high-speed cutting machines, special processing machines, and machines that need large-area lubrication and cooling effects.
2. COM requires 4-8kgf/cm² pneumatic pressure supply to operate.
3. COM has an oil volume adjuster that enables the users to adjust the discharge volume upon the need.
4. COM has an oil-dripping window that enables the users to check if COM discharges oil normally.
5. COM has an oil level indicator that enables the users to check the oil level inside the oil tank. A float switch can be added to COM on request to detect the oil level automatically.
6. Recommend adding an OB spray gun to COM outlet for lubricating a non-fixed lubrication point. A magnetic base can be added to an OB spray gun on request, enabling it to be fixed on any magnetic metal surface at any angle and relocated quickly. The net weight of OB spray gun is 149g.
7. COM is suitable for oil and cutting fluid.

◆ Technical Data & Dimensional Data

Tank Capacity	Length (mm)	Width (mm)	Height (mm)	Mounting Hole Distance (mm)	Pneumatic Pressure	Air Inlet Thread	Oil-Mist Outlet Thread	Suitable Temperature	Suitable Viscosity	N.W. (kg)
2L	146	140	324	300	4-8 kgf/cm ²	PT1/4	PT1/4	5-60°C	32-68 cSt@40°C	4.1

◆ Order Code

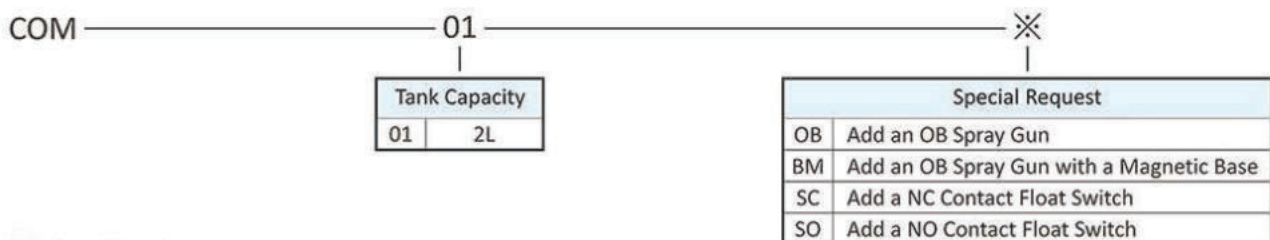

◆ Related Products



CLAB Pressure-Relief Type Oil Manual Lubricator



CLAB-6-D-H-1

CLAB-8-R-H-1

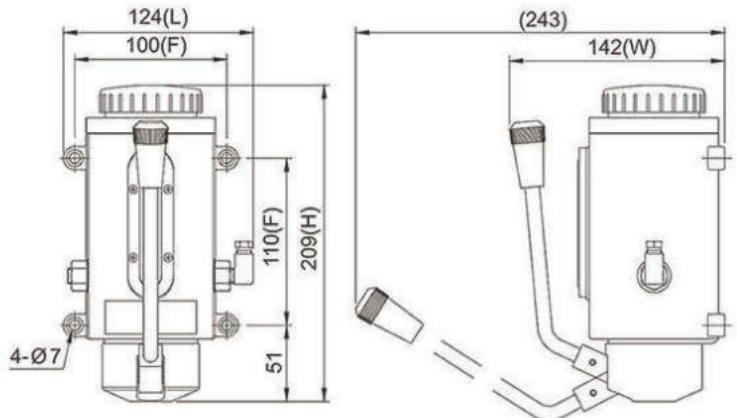

Dimensional Drawing of CLAB-8-R-H-1

◆ Features

1. The compact size of CLAB makes the installation easy.
2. CLAB discharges oil whenever its handle is pulled.
3. The outlet of CLAB can be on either the right side or the left side of the handle. A dual-outlet model is also available for selection.
4. CLAB has to work with volume distributors to deliver the metered quantity of oil to the lubrication point.
5. CLAB can work with machines that do not require oil feeding at a particular time.

◆ Technical Data & Dimensional Data

Model	Tank Capacity	Length (mm)	Width (mm)	Height (mm)	Mounting Hole Distance (mm)	Max. Discharge Volume	Max. Operating Pressure	Suitable Viscosity	Discharge Bore	Outlet Number	N.W. (kg)
CLAB-6	350cc	111	137	188	85x85	8cc/stroke	15 kgf/cm ²	Oil 32-68 cSt@40°C	Ø4	1	1.23
										2	1.24
									Ø6	1	1.24
										2	1.25
CLAB-8	600cc	124	142	209	100x110	8cc/stroke	15 kgf/cm ²	Oil 32-68 cSt@40°C	Ø4	1	1.48
										2	1.50
									Ø6	1	1.49
										2	1.52

◆ Order Code

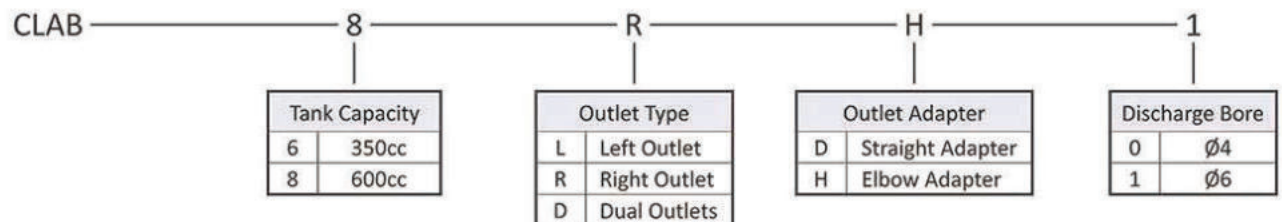

◆ Related Products



P. 89

P. 93

P. 109

P. 111

P. 120

P. 124

P. 123

P. 127

P. 125

CEN03 Pressure-Relief Type Oil Electric Lubricator PLC



CEN03-01-C-3

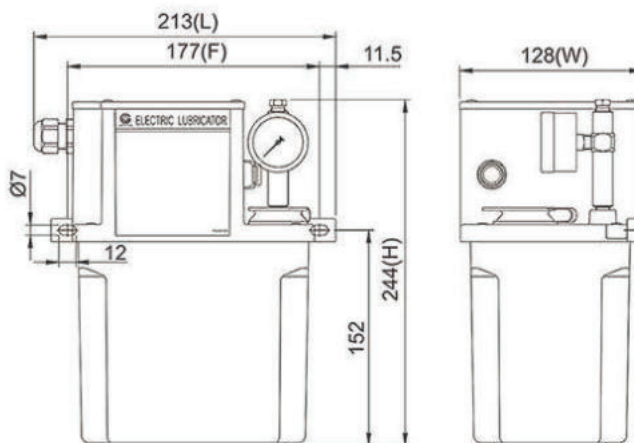

Dimensional Drawing of CEN03-01-C-3

◆ Features

1. The operation and interval time of CEN03 are controlled by PLC.
2. CEN03 has to work with volume distributors to deliver the metered quantity of oil to the lubrication point.
3. CEN03 has a pressure gauge that enables the user to check the operating pressure easily.
4. CEN03 has an 8kgf/cm² NC contact socket pressure switch that detects the operating pressure automatically and sends signals when the pressure is below the preset value.
5. CEN03 has a NC contact float switch that detects the oil level automatically and sends signals when the oil level is low.
6. CEN03 has a spark quencher that prevents the spark of switch contacts and the interference of surge voltage with the PLC and prolongs the service life.
7. CEN03 has a feed-oil button, which can be used as manual oil feeding for less than 3 minutes to avoid overloading the motor.
8. CEN03 has a thermal control that shuts down the motor for about 5 minutes when the motor is overheated.

◆ Order Code

CEN03 — 01 — C — 3 — ※

Tank Capacity (Material)		Voltage		Discharge Bore	
01	2L (Resin)	A	110V, 60Hz	0	∅4
02	2L (Alum.)	B	220V, 50Hz	1	∅6
03	3L (Resin)	C	220V, 60Hz	2	∅4 W/P.G.
04	4L (Resin)			3	∅6 W/P.G.
05	4L (Alum.)				
08	8L (Iron)				

※ P.G. = Pressure Gauge

Special Request	
B	Add a Buzzer
PO	NO Contact Pressure Switch
SO	NO Contact Float Switch
Z	Increase Discharge Volume to 260cc/min

◆ Dimensional Data

Tank Capacity	Tank Material	Length (mm)	Width (mm)	Height (mm)	Mounting Hole Distance (mm)	N.W. (kg)
2L	Resin	213	128	244	177	3.45
2L	Alum.	221	150	234	95x200	4.56
3L	Resin	227	167	248	205	3.91
4L	Resin	277	162	259	250	4.35
4L	Alum.	297	170	253	95x280	5.35
8L	Iron	355	201	270	95x338	8.00

◆ Wiring Diagram

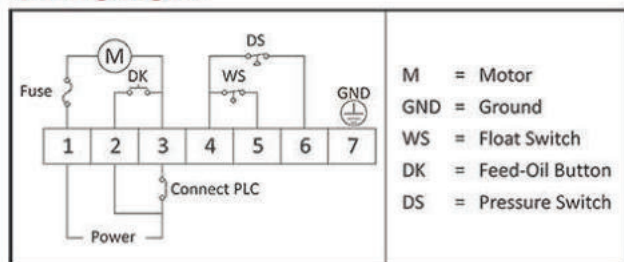

◆ Technical Data

Motor Power	30±3W	
Voltage	110V	220V
Ampere	2A	1A
Hertz	60Hz	50Hz, 60Hz
Max. Discharge Volume	130cc/min, 260cc/min	
Max. Operating Pressure	15kgf/cm ²	
Discharge Bore	∅4, ∅6	
Float Switch	NC Contact (NO Contact on request)	
Pressure Switch	NC Contact (NO Contact on request)	
Suitable Viscosity	Oil, 32-68 cSt@40°C	

◆ Related Products



CESG03 Pressure-Relief Type Oil Electric Lubricator PLC



CESG03-01-C-3

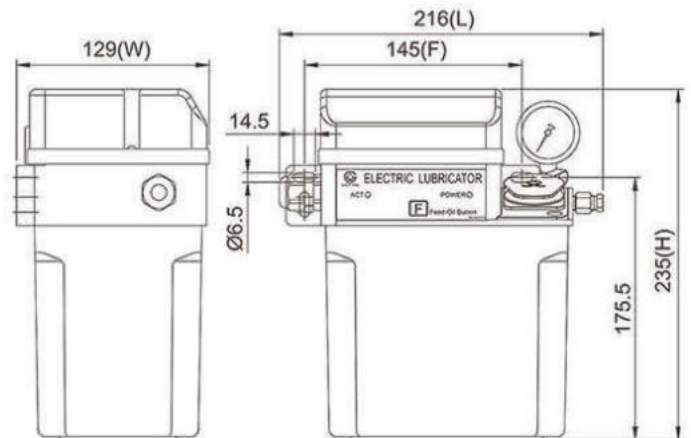

Dimensional Drawing of CESG03-01-C-3

◆ Features

1. The operation and interval time of CESG03 are controlled by PLC.
2. CESG03 has to work with volume distributors to deliver the metered quantity of oil to the lubrication point.
3. CESG03 has a pressure gauge that enables the user to check the operating pressure easily.
4. CESG03 has a NC contact float switch that detects the oil level automatically and sends signals when the oil level is low.
5. CESG03 has a feed-oil button (F button), which can be used as manual oil feeding for less than 3 minutes to avoid overloading the motor.
6. CESG03 has a thermal control that shuts down the motor for about 5 minutes when the motor is overheated.
7. An 8kgf/cm² socket pressure switch can be added to CESG03 on request to detect the operating pressure automatically.

◆ Order Code

CESG03 — 01 — C — 3 — ※

Tank Capacity (Material)	Voltage	Discharge Bore
01 2L (Resin)	A 110V, 60Hz	0 Ø4
02 2L (Alum.)	B 220V, 50Hz	1 Ø6
03 3L (Resin)	C 220V, 60Hz	2 Ø4 W/P.G.
04 4L (Resin)		3 Ø6 W/P.G.
05 4L (Alum.)		
08 8L (Iron)		

※ P.G. = Pressure Gauge

Special Request	
PC	Add a NC Contact Pressure Switch
PO	Add a NO Contact Pressure Switch
SO	NO Contact Float Switch
Z	Increase Discharge Volume to 260cc/min

◆ Dimensional Data

Tank Capacity	Tank Material	Length (mm)	Width (mm)	Height (mm)	Mounting Hole Distance (mm)	N.W. (kg)
2L	Resin	216	129	235	145	2.71
2L	Alum.	221	150	225	95x200	3.80
3L	Resin	227	167	239	205	3.17
4L	Resin	277	162	250	250	3.70
4L	Alum.	297	170	244	95x280	4.61
8L	Iron	355	201	261	95x338	7.26

◆ Wiring Diagram

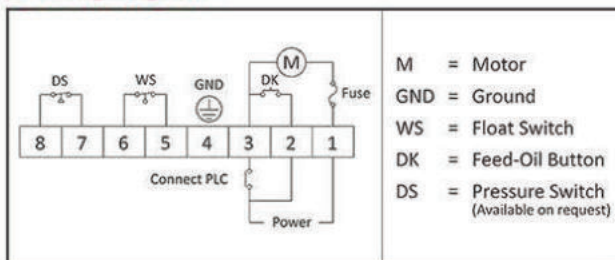

◆ Technical Data

Motor Power	25±3W	
Voltage	110V	220V
Ampere	1.8A	0.9A
Hertz	60Hz	50Hz, 60Hz
Max. Discharge Volume	130cc/min, 260cc/min	
Max. Operating Pressure	15kgf/cm ²	
Discharge Bore	Ø4, Ø6	
Float Switch	NC Contact (NO Contact on request)	
Pressure Switch	Optional (NC or NO Contact)	
Suitable Viscosity	Oil, 32-68 cSt@40°C	

◆ Related Products



CEVB Pressure-Relief Type Oil Electric Lubricator

PLC



CEVB-03-C-25-3-F-L

CEVB-04-C-25-3-F-L

CEVB-08-C-60-3-F-L

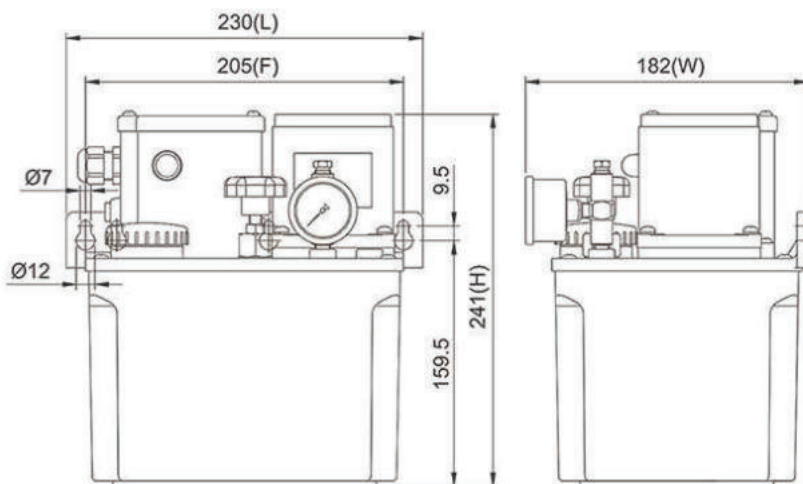

Dimensional Drawing of CEVB-03-C-25-3-F-L

◆ Features

1. The operation and interval time of CEVB are controlled by PLC.
2. CEVB has to work with volume distributors to deliver the metered quantity of oil to the lubrication points.
3. CEVB has a pressure gauge that enables the user to check the operating pressure easily.
4. CEVB has an 8kgf/cm² NC contact socket pressure switch that detects the operating pressure automatically and sends a signal when the pressure is below the preset value.
5. CEVB has a NC contact float switch that detects the oil level automatically and sends signals when the oil level is low.
6. CEVB has a pressure-regulating valve that enables the user to adjust the operating pressure.
7. The gear pump of CEVB is made of special aluminum alloy and assembled with the induction motor to provide stable output pressure, low operating noise, and long service life.
8. CEVB can be added with the following parts on request.
 - A feed-oil button can be used for manual oil feeding.
 - An indicator light that shows when CEVB discharges oil.

◆ Dimensional Data

Motor Power	Tank Capacity	Tank Material	Length (mm)	Width (mm)	Height (mm)	Mounting Hole Distance (mm)	N.W. (kg)
25W	3L	Resin	230	182	241	205	4.89
	4L	Resin	288	162	252	250	5.37
	4L	Aluminum	297	170	250	95x280	6.25
	8L	Iron	355	201	273	95x338	9.52
60W	4L	Aluminum	297	175	310	95x280	7.87
	8L	Iron	355	201	332	95x338	11.35

CEVB Pressure-Relief Type Oil Electric Lubricator

PLC

◆ Technical Data

Motor Power	25W			60W		
Voltage	1Ø110V	1Ø220V	Three Phase	1Ø110V	1Ø220V	Three Phase
Ampere	0.6A	0.3A	0.3A	1.2A	0.6A	0.6A
Max. Discharge Volume	250cc/min			500cc/min		
Max. Operating Pressure	20kgf/cm ²			30kgf/cm ²		
Hertz	50/60Hz Compatible					
Discharge Bore	Ø4, Ø6					
Float Switch	NC Contact (NO Contact on request)					
Pressure Switch	NC Contact (NO Contact on request)					
Suitable Viscosity	Oil, 32-68 cSt@40°C					

◆ Order Code

CEVB — 03 — C — 25 — 3 — ※

Tank Capacity (Material)		Voltage		Discharge Bore		Special Request	
03	3L (Resin)	A	1Ø110V	0	Ø4	F	Add a Feed-Oil Button
04	4L (Resin)	C	1Ø220V	1	Ø6	L	Add a Indicator Light
05	4L (Alum.)	D	3Ø220/380V	2	Ø4 W/Pressure Gauge	PO	NO Contact Pressure Switch
08	8L (Iron)	E	3Ø220/440V	3	Ø6 W/Pressure Gauge	SO	NO Contact Float Switch
20	20L (Iron)	F	3Ø208/415V				
		G	3Ø230/460V				
		H	3Ø240/480V				
		M	3Ø220V				
		N	3Ø380V				
		X	Special Voltage				

Motor Power	
25	25W
60	60W (Available for 4L metal tank and above only)
90	90W (Available for 4L metal tank and above only)

※ A standard dual-voltage motor is connected for low voltage. Please specify if you need it to be connected for high voltage when placing an order.

◆ Wiring Diagram

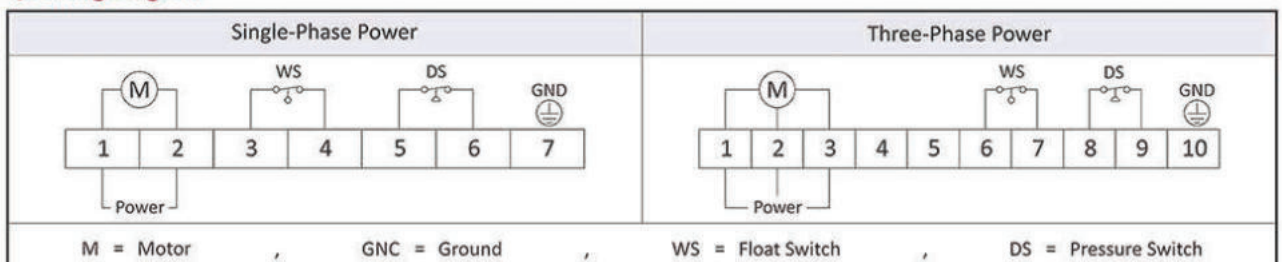

※ For the CEVB with a feed-oil button and an indicator light, please follow the particular wiring diagram on the CEVB.

※ The motor shaft is marked with a red dot. When wiring the three-phase-voltage CEVB, please note that the motor should rotate anticlockwise. If the motor rotates clockwise, please switch the position of any two of the power wires and rewire them.

◆ Related Products



P. 89

P. 93

P. 109

P. 111

P. 120

P. 124

P. 123

P. 127

P. 125

CEPB Pressure-Relief Type Oil Electric Lubricator Timer



CEPB-01-C-3-2

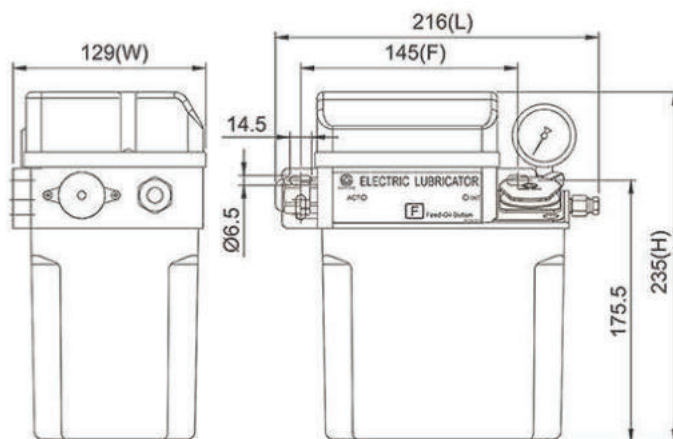

Dimensional Drawing of CEPB-01-C-3-2

◆ Features

1. The time adjusters are inside the control box of CEPB. There are eight kinds of operation time and interval time for selection.
2. There are operation (ACT) and interval (INT) indicators on the control box.
3. There are two operation modes after the power of CEPB is on. The standard mode is turn on interval.
 - Turn-on-feeding: Operation time starts first after the power is on.
 - Turn-on-interval: Interval time starts first after the power is on.
4. Turn-on-interval model has a memory function. If the power is suddenly off during the interval time, CEPB will continue to operate from the remaining interval time after restarting, which can effectively avoid over-lubrication.
5. CEPB has to work with volume distributors to deliver the metered quantity of oil to the lubrication points.
6. CEPB has a pressure gauge that enables the user to check the operating pressure easily.
7. CEPB has a NC contact float switch that detects the oil level automatically and sends signals when the oil level is low.
8. CEPB has a buzzer that sends an alarm sound when the oil level is low.
9. CEPB has a feed-oil button (F button), which can be used as manual oil feeding for less than 3 minutes to avoid overloading the motor.
10. CEPB has a thermal control that shuts down the motor for about 5 minutes when the motor is overheated.

◆ Order Code

CEPB — 01 — C — 3 — 2 — ※

Tank Capacity (Material)	
01	2L (Resin)
02	2L (Alum.)
03	3L (Resin)
04	4L (Resin)
05	4L (Alum.)
08	8L (Iron)

Voltage	
A	110V, 60Hz
B	220V, 50Hz
C	220V, 60Hz

Discharge Bore	
0	Ø4
1	Ø6
2	Ø4 W/P.G.
3	Ø6 W/P.G.

※ P.G. = Pressure Gauge

Operation Mode	
1	Turn-on-Feeding
2	Turn-on-Interval

Special Request	
Z	Increase Discharge Volume to 260cc/min

◆ Dimensional Data

Tank Capacity	Tank Material	Length (mm)	Width (mm)	Height (mm)	Mounting Hole Distance (mm)	N.W. (kg)
2L	Resin	216	129	235	145	2.73
2L	Alum.	221	150	225	95x200	3.87
3L	Resin	227	167	239	205	3.15
4L	Resin	277	162	250	250	3.70
4L	Alum.	297	170	244	95x280	4.70
8L	Iron	355	201	261	95x338	7.35

◆ Technical Data

Operation Time	2, 3, 5, 10, 15, 20, 25, 30 sec	
Interval Time	3, 5, 10, 15, 20, 30, 60, 180 min	
Motor Power	25±3W	
Voltage	110V	220V
Ampere	1.8A	0.9A
Hertz	60Hz	50Hz, 60Hz
Max. Discharge Volume	130cc/min, 260cc/min	
Max. Operating Pressure	15kgf/cm ²	
Discharge Bore	Ø4, Ø6	
Float Switch	NC Contact	
Suitable Viscosity	Oil, 32-68 cSt@40°C	

◆ Wiring Diagram

Power	Ground	Abnormal Output		
POWER	GND(P.E)	COM	NC(B)	NO(A)
⊕	⊕	⊕	⊕	⊕

◆ Related Products



P. 89

P. 93

P. 109

P. 111

P. 120

P. 124

P. 123

P. 127

P. 125

CEWB Pressure-Relief Type Oil Electric Lubricator Timer



CEWB-01-2-C-3-2

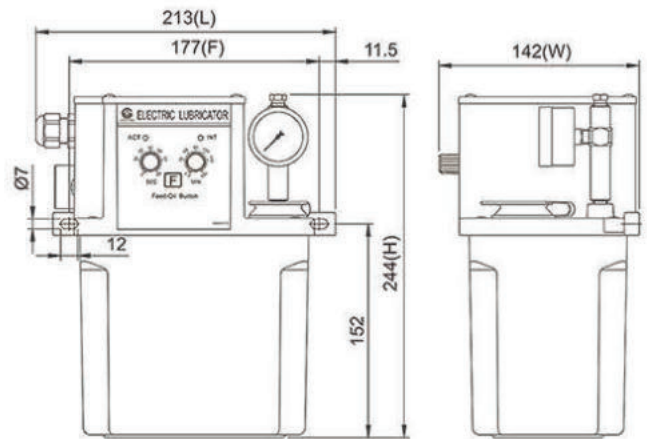

Dimensional Drawing of CEWB-01-2-C-3-2

◆ Features

- The operation and interval time adjusters are on the control box of CEWB. There are operation (ACT) and interval (INT) indicators on the control box.
- There are two operation modes after the power of CEWB is on. The standard mode is turn on interval.
 - Turn-on-feeding: Operation time starts first after the power is on.
 - Turn-on-interval: Interval time starts first after the power is on.
- Turn-on-interval model has a memory function. If the power is suddenly off during the interval time, CEWB will continue to operate from the remaining interval time after restarting, which can effectively avoid over-lubrication.
- CEWB has to work with volume distributors to deliver the metered quantity of oil to the lubrication points.
- CEWB has a pressure gauge that enables the user to check the operating pressure easily.
- CEWB has a NC contact float switch that detects the oil level automatically and sends signals when the oil level is low.
- CEWB has a buzzer that sends an alarm sound when the oil level is low.
- CEWB has a feed-oil button (F button), which can be used as manual oil feeding for less than 3 minutes to avoid overloading the motor.
- CEWB has a thermal control that shuts down the motor for about 5 minutes when the motor is overheated.

◆ Order Code

CEWB — 01 — 2 — C — 3 — 2 — ※

Tank Capacity (Material)	
01	2L (Resin)
02	2L (Alum.)
03	3L (Resin)
04	4L (Resin)
05	4L (Alum.)
08	8L (Iron)

Voltage	
A	110V, 60Hz
B	220V, 50Hz
C	220V, 60Hz

Discharge Bore	
0	∅4
1	∅6
2	∅4 W/P.G.
3	∅6 W/P.G.

※ P.G. = Pressure Gauge

ACT x INT	
1	60sec x 60min
2	60sec x 180min
3	60sec x 12hr
4	60sec x 72hr

Operation Mode	
1	Turn-on-Feeding
2	Turn-on-Interval

Special Request	
Z	Increase Discharge Volume to 260cc/min

◆ Dimensional Data

Tank Capacity	Tank Material	Length (mm)	Width (mm)	Height (mm)	Mounting Hole Distance (mm)	N.W. (kg)
2L	Resin	213	142	244	177	3.42
2L	Alum.	221	156	234	95x200	4.53
3L	Resin	227	167	248	205	3.86
4L	Resin	277	162	259	250	4.36
4L	Alum.	297	173	253	95x280	5.36
8L	Iron	355	201	270	95x338	8.06

◆ Technical Data

Operation Time	3-60 sec	
Interval Time	1-60min, 1-180min, 1-12hr, 1-72hr	
Motor Power	30±3W	
Voltage	110V	220V
Ampere	2A	1A
Hertz	60Hz	50Hz, 60Hz
Max. Discharge Volume	130cc/min, 260cc/min	
Max. Operating Pressure	15kgf/cm ²	
Discharge Bore	∅4, ∅6	
Float Switch	NC Contact	
Suitable Viscosity	Oil, 32-68 cSt@40°C	

◆ Wiring Diagram

Abnormal Output			Ground	Power
NO(A)	NC(B)	COM	GND(P.E)	POWER
⊕	⊕	⊕	⊕	⊕

◆ Related Products



P. 89

P. 93

P. 109

P. 111

P. 120

P. 124

P. 123

P. 127

P. 125

CEN04 Pressure-Relief Type Oil Timer Electric Lubricator



CEN04-01-2-C-3

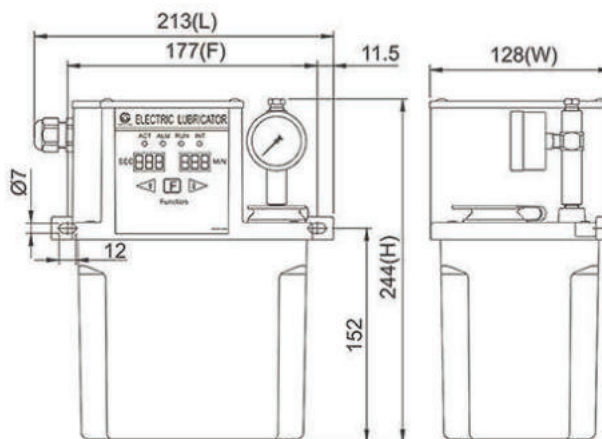

Dimensional Drawing of CEN04-01-2-C-3

◆ Features

- CEN04 has a timer that controls its operation and interval time. The control box has a built-in buzzer that sends an alarm sound when the oil level is low. The control box also has four indicators, operation (ACT), alarm (ALM), immediate lubrication (RUN), and interval (INT).
- CEN04 has to work with volume distributors to deliver the metered quantity of oil to the lubrication points.
- CEN04 can memorize the set value of operation time and interval time.
- There are two operation modes after the power of CEN04 is on. The standard mode is turn on feeding.
 - Turn-on-feeding: Operation time starts first after the power is on.
 - Turn-on-interval: Interval time starts first after the power is on.
- Turn-on-interval model has a memory function. If the power is suddenly off during the interval time, CEN04 will continue to operate from the remaining interval time after restarting, which can effectively avoid over-lubrication.
- CEN04 has a pressure gauge that enables the user to check the operating pressure easily.
- CEN04 has an 8kgf/cm² NC contact socket pressure switch that detects the operating pressure automatically.
- CEN04 has a NC contact float switch that detects the oil level automatically and sends signals when the oil level is low.
- CEN04 has a feed-oil button (F button), which can be used as manual oil feeding for less than 3 minutes to avoid overloading the motor.
- CEN04 has a thermal control that shuts down the motor for about 5 minutes when the motor is overheated.

◆ Order Code

CEN04 - 01 - 2 - C - 3 - ※

Tank Capacity (Material)		ACT x INT		Voltage	
01	2L (Resin)	1	sec x sec	A	110V, 60Hz
02	2L (Alum.)	2	sec x min	B	220V, 50Hz
03	3L (Resin)			C	220V, 60Hz
04	4L (Resin)				
05	4L (Alum.)				
08	8L (Iron)				

Discharge Bore	
0	∅4
1	∅6
2	∅4 W/Pressure Gauge
3	∅6 W/Pressure Gauge

Special Request	
2	Turn-on-Interval Operation Mode
B	Add a Larger Buzzer
Z	Increase Discharge Volume to 260cc/min

◆ Dimensional Data

Tank Capacity	Tank Material	Length (mm)	Width (mm)	Height (mm)	Mounting Hole Distance (mm)	N.W. (kg)
2L	Resin	213	128	244	177	3.55
2L	Alum.	221	150	234	95x200	4.66
3L	Resin	227	167	248	205	3.99
4L	Resin	277	162	259	250	4.45
4L	Alum.	297	170	253	95x280	5.45
8L	Iron	355	201	270	95x338	8.10

◆ Technical Data

Operation Time	1-999 sec
Interval Time	1-999 sec, 1-999 min
Motor Power	30±3W
Voltage	110V 220V
Ampere	2A 1A
Hertz	60Hz 50Hz, 60Hz
Max. Discharge Volume	130cc/min, 260cc/min
Max. Operating Pressure	15kgf/cm ²
Discharge Bore	∅4, ∅6
Float Switch	NC Contact
Pressure Switch	NC Contact
Suitable Viscosity	Oil, 32-68 cSt@40°C

◆ Wiring Diagram

Abnormal Output			Ground	Power
NO(A)	NC(B)	COM	GND(P.E)	POWER
⊕	⊕	⊕	⊕	⊕

◆ Related Products



P. 89

P. 93

P. 109

P. 111

P. 120

P. 124

P. 123

P. 127

P. 125

CESG04 Pressure-Relief Type Oil Timer Electric Lubricator



CESG04-01-2-C-3

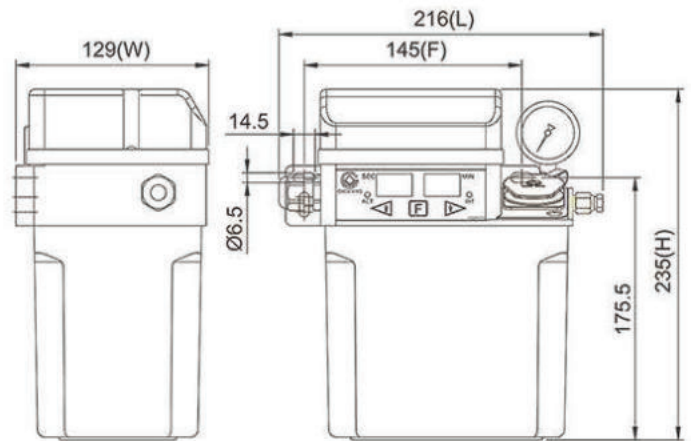

Dimensional Drawing of CESG04-01-2-C-3

◆ Features

- CESG04 has a timer that controls its operation and interval time. The control box has a built-in buzzer that sends an alarm sound when the oil level is low. The control box also has two indicators, operation (ACT), and interval (INT).
- CESG04 has to work with volume distributors to deliver the metered quantity of oil to the lubrication points.
- CESG04 can memorize the set value of operation time and interval time.
- There are two operation modes after the power of CESG04 is on. The standard mode is turn on feeding.
 - Turn-on-feeding: Operation time starts first after the power is on.
 - Turn-on-interval: Interval time starts first after the power is on.
- Turn-on-interval model has a memory function. If the power is suddenly off during the interval time, CESG04 will continue to operate from the remaining interval time after restarting, which can effectively avoid over-lubrication.
- CESG04 has a pressure gauge that enables the user to check the operating pressure easily.
- CESG04 has a NC contact float switch that detects the oil level automatically and sends signals when the oil level is low.
- CESG04 has a feed-oil button (F button), which can be used as manual oil feeding for less than 3 minutes to avoid overloading the motor.
- CESG04 has a thermal control that shuts down the motor for about 5 minutes when the motor is overheated.
- An 8kgf/cm² NC contact socket pressure switch can be added to CESG04 on request to detect the operating pressure automatically.

◆ Order Code

CESG04 - 01 — 2 — C — 3 — ※

Tank Capacity (Material)	ACT x INT	Voltage
01 2L (Resin)	1 sec x min	A 110V, 60Hz
02 2L (Alum.)	2 sec x hour	B 220V, 50Hz
03 3L (Resin)		C 220V, 60Hz
04 4L (Resin)		
05 4L (Alum.)		
08 8L (Iron)		

Discharge Bore	
0	Ø4
1	Ø6
2	Ø4 W/Pressure Gauge
3	Ø6 W/Pressure Gauge

Special Request	
2	Turn-on-Interval Operation Mode
B	Add a Larger Buzzer
PC	Add a NC Contact Pressure Switch
Z	Increase Discharge Volume to 260cc/min

◆ Wiring Diagram

Abnormal Output			Ground	Power
NO(A)	NC(B)	COM	GND(P.E)	POWER
⊕	⊕	⊕	⊕	⊕

◆ Related Products



P. 89

P. 93

P. 109

P. 111

P. 120

P. 124

P. 123

P. 127

P. 125

◆ Dimensional Data

Tank Capacity	Tank Material	Length (mm)	Width (mm)	Height (mm)	Mounting Hole Distance (mm)	N.W. (kg)
2L	Resin	216	129	235	145	2.75
2L	Alum.	221	150	225	95x200	3.86
3L	Resin	227	167	239	205	3.21
4L	Resin	277	162	250	250	3.74
4L	Alum.	297	170	244	95x280	4.65
8L	Iron	355	201	261	95x338	7.30

◆ Technical Data

Operation Time	1-999 sec	
Interval Time	1-999 min, 1-999 hour	
Motor Power	25±3W	
Voltage	110V	220V
Ampere	1.8A	0.9A
Hertz	60Hz	50Hz, 60Hz
Max. Discharge Volume	130cc/min, 260cc/min	
Max. Operating Pressure	15kgf/cm ²	
Discharge Bore	Ø4, Ø6	
Float Switch	NC Contact (NO Contact on request)	
Pressure Switch	Optional (NC Contact)	
Suitable Viscosity	Oil, 32-68 cSt@40°C	

CENB Pressure-Relief Type Oil Electric Lubricator

Timer

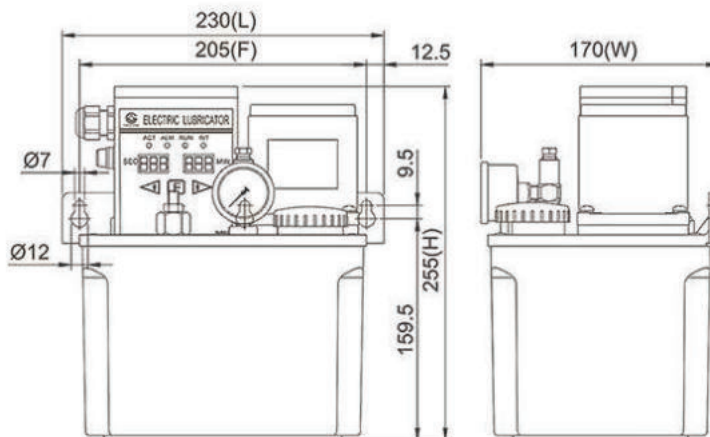

CENB-03-2-C-25-3

Dimensional Drawing of CENB-03-2-C-25-3

◆ Features

- CENB has a timer that controls its operation and interval time. The control box has a built-in buzzer that sends an alarm sound when the oil level is low. The control box also has four indicators, operation (ACT), alarm (ALM), immediate lubrication (RUN), and interval (INT).
- CENB has to work with volume distributors to deliver the metered quantity of oil to the lubrication points.
- CENB can memorize the set value of operation time and interval time.
- CENB has a pressure gauge that enables the user to check the operating pressure easily.
- CENB has a NC contact float switch that detects the oil level automatically and sends signals when the oil level is low.
- CENB has a pressure-regulating valve that enables the user to adjust the operating pressure.
- CENB has a feed-oil button (F button), which can be used as manual oil feeding for less than 3 minutes to avoid overloading the motor.
- CENB with 3L above tank has an 8kgf/cm² NC contact socket pressure switch that detects the operating pressure automatically.
- The gear pump of CENB is made of special aluminum alloy and assembled with the induction motor to provide stable output pressure, low operating noise, and long service life. It meets the requirements of most large machines.

◆ Dimensional Data

Motor Power	Tank Capacity	Tank Material	Length (mm)	Width (mm)	Height (mm)	Mounting Hole Distance (mm)	N.W. (kg)
25W	2L	Aluminum	222	167	245	95x200	5.81
	3L	Resin	230	170	255	205	5.10
	4L	Resin	277	162	266	250	5.50
	4L	Aluminum	297	170	264	95x280	6.41
	8L	Iron	355	201	285	95x338	9.54
60W	4L	Aluminum	297	170	311	95x280	8.15
	8L	Iron	355	201	331	95x338	10.55

◆ Technical Data

Operation Time	1-999 sec			
Interval Time	1-999 sec, 1-999 min			
Motor Power	25W		60W	
Voltage	110V	220V	110V	220V
Ampere	0.6A	0.3A	1.2A	0.6A
Max. Discharge Volume	250cc/min		500cc/min	
Max. Operating Pressure	20kgf/cm ²		30kgf/cm ²	
Hertz	50/60Hz Compatible			
Discharge Bore	Ø4, Ø6			
Float Switch	NC Contact			
Pressure Switch	NC Contact			
Suitable Viscosity	Oil, 32-68 cSt@40°C			

◆ Wiring Diagram

Abnormal Output			Ground	Power
NO(A)	NC(B)	COM	GND(P.E)	POWER
⊕	⊕	⊕	⊕	⊕

◆ Order Code

CENB — 03 — 2 — C — 25 — 3 — ✱

Tank Capacity (Material)	ACT x INT	Voltage	Motor Power	Discharge Bore	Special Request
02 2L (Alum.)	1 sec x sec	A 110V	25 25W	0 Ø4	B Add a Larger Buzzer
03 3L (Resin)	2 sec x min	B 220V	60 60W	1 Ø6	
04 4L (Resin)			90 90W	2 Ø4 W/Pressure Gauge	
05 4L (Alum.)				3 Ø6 W/Pressure Gauge	
08 8L (Iron)					

✱ 60W and 90W motors are only available for CENB with a 4L metal tank and above.

◆ Related Products



PNB Pressure-Relief Type Pneumatic Lubricator



PNB-01-3-0

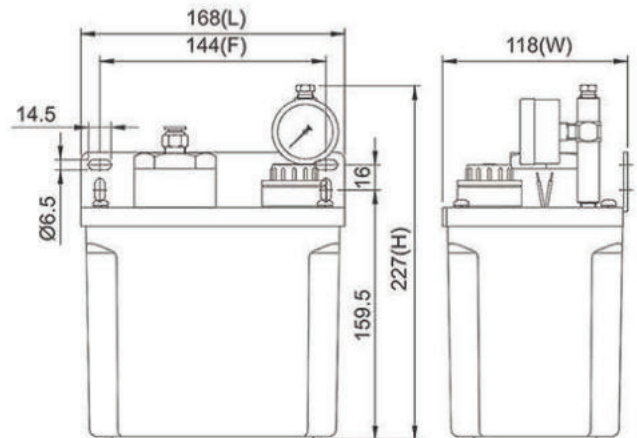

Dimensional Drawing of PNB-01-3-0

◆ Features

1. PNB is actuated pneumatically by a solenoid valve to discharge oil intermittently. The pneumatic pressure supply controls the output pressure of PNB.
2. PNB requires 4-8 kgf/cm² pneumatic pressure supply and 5 seconds above ON/OFF time of the solenoid valve to work functionally.
3. PNB has to work with volume distributors to deliver the metered quantity of oil to the lubrication points.
4. PNB has a pressure gauge that enables the user to check the operating pressure easily.
5. PNB has a NC contact float switch that detects the oil level automatically and sends signals when the oil level is low.
6. An 8kgf/cm² socket pressure switch can be added to PNB on request to detect the operating pressure automatically.
7. A magnetic filter and a partition can be added to PNB on request to filter the oil that returns to the oil tank through the cyclic inlet.
 - 3L oil tank and above can add a magnetic filter.
 - 3L, 4L resin oil tanks, and 8L iron oil tanks can add a partition.

◆ Order Code

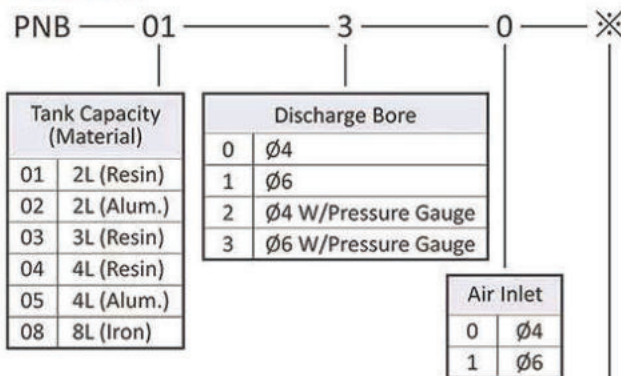

Special Request	
C	Add a Magnetic Filter (Available for 3L and above tanks only)
D	Add a Partition (Available for 3L, 4L resin tanks, and 8L iron tanks only)
PC	Add a NC Contact Pressure Switch
PO	Add a NO Contact Pressure Switch
SO	NO Contact Float Switch

◆ Dimensional Data

Tank Capacity	Tank Material	Length (mm)	Width (mm)	Height (mm)	Mounting Hole Distance (mm)	N.W. (kg)
2L	Resin	168	118	227	144	2.27
2L	Alum.	217	150	212	95x200	3.07
3L	Resin	231	166	222	205	2.86
4L	Resin	277	160	236	250	2.68
4L	Alum.	297	170	232	95x280	4.14
8L	Iron	355	201	252	95x338	7.24

◆ Technical Data

Pneumatic Pressure (kgf/cm ²)	4	5	6	7	8
Operating Pressure (kgf/cm ²)	14	18	23	28	33
Discharge Volume	8cc/stroke				
Air Inlet	∅4, ∅6 (Outer Thread PT1/4)				
Discharge Bore	∅4, ∅6				
Float Switch	NC Contact (NO Contact on request)				
Pressure Switch	Optional (NC or NO Contact)				
Suitable Viscosity	Oil, 10-220 cSt@40°C				

◆ Related Products



P. 89

P. 93

P. 109

P. 111

P. 119

P. 120

P. 124

P. 123

P. 125

POA Oil-Air Type **PLC** Pneumatic Lubricator



POA-03-C

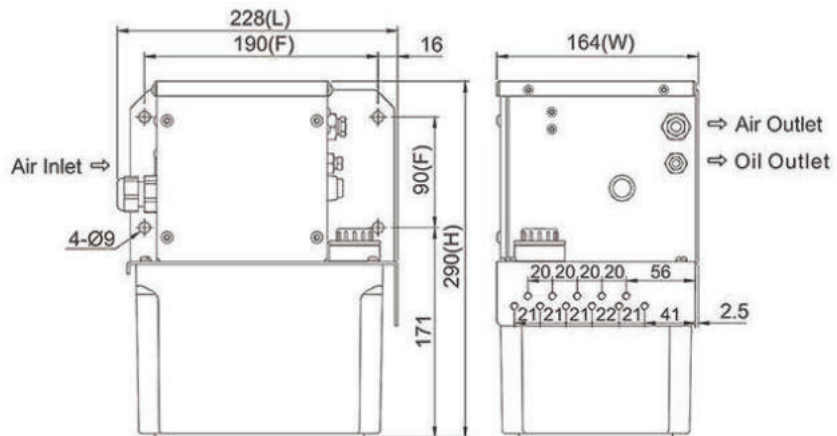

Dimensional Drawing of POA-03-C

◆ Features

1. The operation and interval time of POA are controlled by PLC.
2. POA is actuated by pneumatic and controlled by a solenoid valve, which could be an ON/OFF switch. The input pneumatic pressure determines the output pressure. Oil discharges during operation.
3. Recommend using input pneumatic pressure of 3.5~7 kgf/cm² and setting up a solenoid valve's ON/OFF time of more than 5 seconds for discharging oil.
4. POA has a feed-oil button which can be used for manual oil feeding.
5. Recommend working with OC type oil-air volume distributors to deliver the metered quantity of oil-air mixture to lubrication points.
6. POA has two pressure gauges that enable the user to check the input pneumatic and output operating pressure easily.
7. POA has a NC contact float switch that detects the oil level automatically and sends signals when the oil level is low.
8. POA has three NC Contact socket pressure switches, and the specifications are as follows.
 - ① High Oil-Pressure Switch sets 20 kgf/cm² to detect the operating pressure.
 - ② Low Oil-Pressure Switch sets 1 kgf/cm² to detect the pressure-relief function.
 - ③ Air-Pressure Switch sets 3.5 kgf/cm² to detect the pneumatic pressure.

◆ Order Code

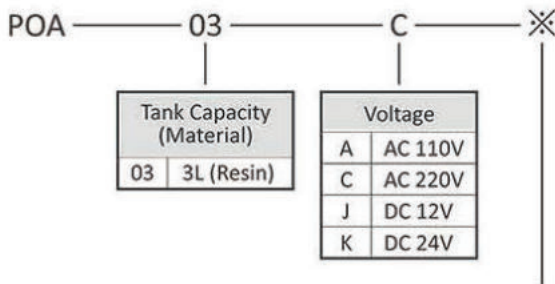

Special Request	
AO	NO Contact Air Pressure Switch
HO	NO Contact High Oil-Pressure Switch
LO	NO Contact Low Oil-Pressure Switch
OC	Add an OC Oil-Air Volume Distributor (Please refer to OC catalog and provide order code.)
SO	NO Contact Float Switch

※ Float switch and pressure switch contact instructions are on pages 118 and 119.

◆ Dimensional Data

Tank Capacity	Tank Material	Length (mm)	Width (mm)	Height (mm)	Mounting Hole Distance (mm)	N.W. (kg)
3L	Resin	228	164	290	90x190	5.50

◆ Technical Data

Voltage	AC110V, AC220V, DC12V, DC24V							
Pneumatic Pressure (kgf/cm ²)	3.5	4.0	4.5	5.0	5.5	6.0	6.5	7.0
Operating Pressure (kgf/cm ²)	26	30	34	38	41	45	49	53
Discharge Volume	5cc/stroke							
Air Inlet	PT3/4							
Air Outlet	Ø8							
Oil Outlet	Ø6							
Float Switch	NC Contact (NO Contact on request)							
Pressure Switch	NC Contact (NO Contact on request)							
Suitable Viscosity	Oil, 10-68 cSt@40°C							

◆ Wiring Diagram

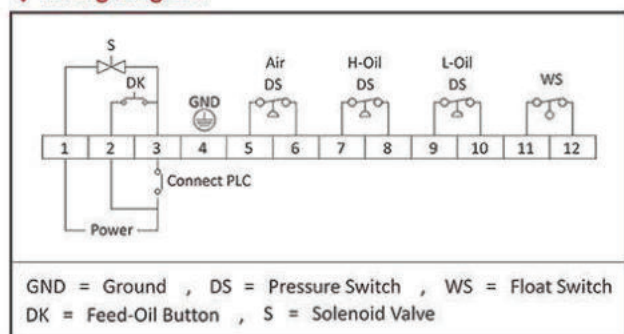

◆ Related Products



P. 96

P. 111

P. 109

P. 123

PNC03 Oil-Air Type **PLC** Pneumatic Lubricator

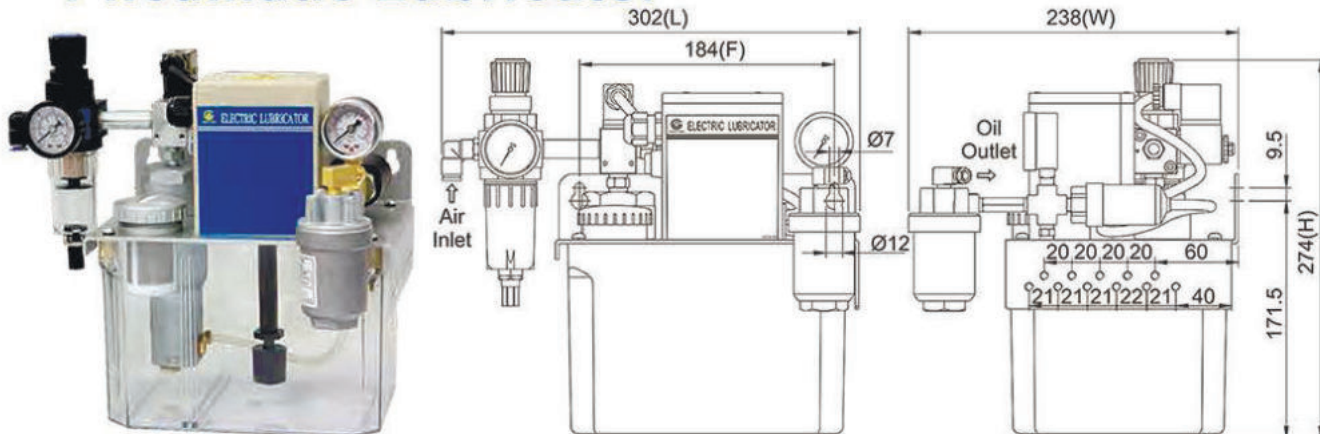

PNC03-03-C-AF-BF

Dimensional Drawing of PNC03-03-C-AF-BF

◆ Features

1. PLC controls the operation and interval time of PNC03.
2. PNC03 is actuated by pneumatic and controlled by a solenoid valve, which could be an ON/OFF switch. The input pneumatic pressure determines the output pressure. Oil discharges during operation.
3. Recommend using input pneumatic pressure of 4-8kgf/cm² and setting up a solenoid valve's ON/OFF time of more than 5 seconds for discharging oil.
4. Recommend working with OC oil air volume distributors that the discharge volume is above 0.03cc to deliver the metered quantity of oil-air mixture to lubrication points.
5. PNC03 has a pressure gauge that enables the user to check the operating pressure easily.
6. PNC03 has a NC float switch that detects the oil level automatically and sends signals when the oil level is low.
7. PNC03 has a 12.5kgf/cm² socket pressure switch that detects the operating pressure automatically.
8. PNC03 has a feed-oil button which can be used for manual oil feeding.
9. PNC03 can add an air filter regulator to filter out water and impurities from the pneumatic supply.
10. PNC03 can add an A-101-2 type filter to filter the impurity from oil.

◆ Order Code

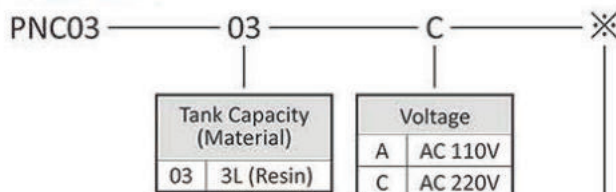

Special Request	
AF	Add an Air Filter Regulator
BF	Add an A-101-2 Filter
OC	Add an OC Oil-Air Distributor (Please refer to OC catalog and provide the order code.) (OC's discharge volume should be above 0.03cc.)
PO	NO Contact Pressure Switch
SO	NO Contact Float Switch

◆ Wiring Diagram

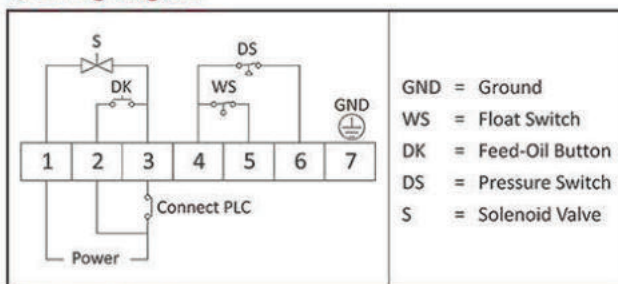

◆ Dimensional Data (PNC03-03-C)

Model	Tank Capacity & Material	Length (mm)	Width (mm)	Height (mm)	Mounting Hole Distance (mm)	N.W. (kg)
Without AF & BF	3L Resin	219	188	256	184	3.60
With AF & BF	3L Resin	302	238	274	184	4.32

※ Float switch and pressure switch contact instructions are on pages 118 and 119.

◆ Technical Data

Voltage	AC110V, AC220V				
	Pneumatic Pressure (kgf/cm ²)	4	5	6	7
Operating Pressure (kgf/cm ²)	14	18	23	28	33
Discharge Volume	8cc/stroke				
Air Inlet	Ø8				
Air Outlet	Ø8				
Oil Outlet	Ø6				
Float Switch	NC Contact (NO Contact on request)				
Pressure Switch	NC Contact (NO Contact on request)				
Suitable Viscosity	Oil, 10-68 cSt@40°C				

◆ Related Products



COA Oil-Air Type Electric Lubricator



COA-03-1-C-25-3

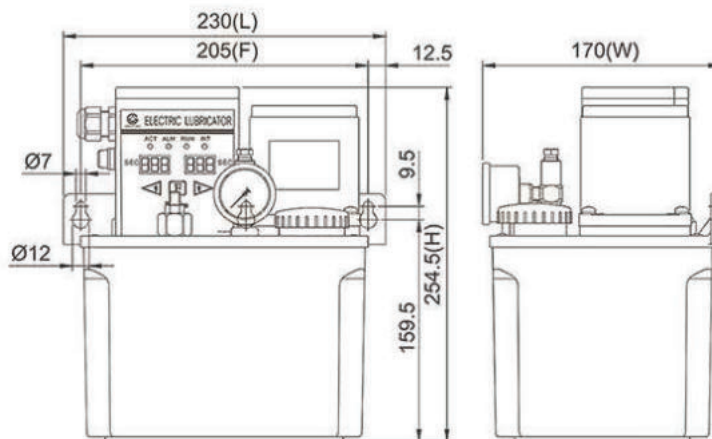

Dimensional Drawing of COA-03-1-C-25-3

◆ Features

1. COA has a timer that controls its operation and interval time. The control box has a built-in buzzer that sends an alarm when the oil level is low. The control box also has four indicators, operation (ACT), alarm (ALM), immediate lubrication (RUN), and interval (INT).
2. COA has to work with CO, OA, or OC type oil-air volume distributors to deliver the metered quantity of oil-air mixture to the lubrication points.
3. COA can memorize the set value of operation time and interval time.
4. COA has a pressure gauge that enables the user to check the operating pressure easily.
5. COA has a NC contact float switch that detects the oil level automatically and sends signals when the oil level is low.
6. COA has a pressure-regulating valve that enables the user to adjust the operating pressure.
7. COA has a feed-oil button (F button), which can be used as manual oil feeding for less than 3 minutes to avoid overloading the motor.
8. COA has an 8kgf/cm² NC NC contact socket pressure switch that detects the operating pressure.
9. The gear pump of COA is made of special aluminum alloy and assembled with the induction motor to provide stable output pressure, low operating noise, and long service life. It meets the requirements of most large machines.

◆ Dimensional Data

Motor Power	Tank Capacity	Tank Material	Length (mm)	Width (mm)	Height (mm)	Mounting Hole Distance (mm)	N.W. (kg)
25W	3L	Resin	230	170	254.5	205	5.10
	4L	Resin	277	162	265.5	250	5.50
	4L	Aluminum	297	170	263.5	95x280	6.41
	8L	Iron	355	201	284.5	95x338	9.54
60W	4L	Aluminum	297	170	310.5	95x280	8.15
	8L	Iron	355	201	331.0	95x338	10.55

◆ Technical Data

Operation Time	1-999 sec			
Interval Time	1-999 sec, 1-999 min			
Motor Power	25W		60W	
Voltage	110V	220V	110V	220V
Ampere	0.6A	0.3A	1.2A	0.6A
Max. Discharge Volume	250cc/min		500cc/min	
Max. Operating Pressure	20kgf/cm ²		30kgf/cm ²	
Hertz	50/60Hz Compatible			
Discharge Bore	Ø4, Ø6			
Float Switch	NC Contact			
Pressure Switch	NC Contact			
Suitable Viscosity	Oil, 32-68 cSt@40°C			

◆ Wiring Diagram

Abnormal Output			Ground	Power
NO(A)	NC(B)	COM	GND(P.E)	POWER
⊕	⊕	⊕	⊕	⊕

◆ Order Code

COA — 03 — 1 — C — 25 — 3 — ✕

Tank Capacity (Material)	ACT x INT	Voltage	Motor Power	Discharge Bore	Special Request
03 3L (Resin)	1 sec x sec	A 110V	25 25W	0 Ø4	B Add a Larger Buzzer
04 4L (Resin)	2 sec x min	B 220V	60 60W	1 Ø6	
05 4L (Alum.)			90 90W	2 Ø4 W/Pressure Gauge	
08 8L (Iron)				3 Ø6 W/Pressure Gauge	

✕ 60W and 90W motors are only available for COA with a 4L metal tank and above.

◆ Related Products



POM Minimum Quantity Oil Pneumatic Lubricator



POM-35-1-A-0



POM-01-1-A-0-SC



POM-50-1-1-0-TC-SC

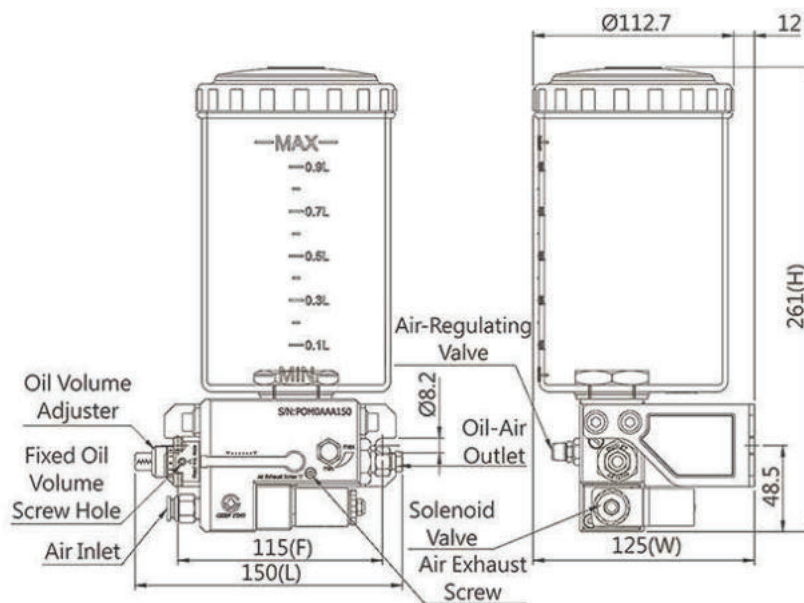

Dimensional Drawing of POM-35-1-A-0

◆ Features

1. The discharge volume of POM is precise and can be adjusted from 0.01cc to 0.08cc per stroke.
2. POM can be actuated either by a frequency generator or a solenoid valve.
 - The pneumatic pressure supply drives the frequency generator, and the user can adjust each stroke frequency upon demand. The service life is ten million cycles.
 - The input voltage powers the solenoid valve, and the PLC can precisely control its stroke frequency. The solenoid valve works as the ON/OFF switch of the pneumatic pressure supply. The service life is two million cycles.
3. POM requires 4-8kgf/cm² pneumatic pressure supply to operate.
4. The standard POM has one outlet, which can be increased to four on request. Do not plug any outlet of POM.
5. POM has an oil volume adjuster for adjusting the discharge volume. The fixed oil volume screw hole secures the oil volume adjuster to prevent its setting from being changed.
6. The air-regulating valve can adjust the air volume upon the need. Turn the air-regulating valve clockwise to decrease the air volume and turn it anti-clockwise to increase the air volume.
7. All POM lubricators have 80-mesh oil filters. The oil inlet of the 2L-square tank has an additional 40-mesh oil filter to filter the impurities.
8. Each outlet of POM can add a reed switch to detect if stroke movements are regular.
9. 2L square tank and 2000cc cylindrical tank can add a float switch to detect oil level automatically.
10. Recommend using vegetable oil viscosity 22~68cSt@40 °C. Forbid filling cutting fluid and volatile lubricants, such as alcohols and ethylene glycol-based lubricants.

POM Minimum Quantity Oil Pneumatic Lubricator

◆ Dimensional Data

Model	Tank Capacity	Mounting Hole Distance (mm)	Oil-Air Outlet Number	Length (mm)	Width (mm)	Height (mm)		N.W. (kg)	
						Without Float Switch	With Float Switch	Without Float Switch	With Float Switch
POM-01	2L Square Oil Tank	115	1	169	121	247	273	2.3	2.4
			2			275	301	2.7	2.8
			3			304	330	3.1	3.2
			4			332	358	3.4	3.6
POM-35	1000cc Cylindrical Oil Tank	115	1	150	125	261	--	1.5	--
			2			290	--	2.0	--
			3			318	--	2.4	--
			4			347	--	2.8	--
POM-50	2000cc Cylindrical Oil Tank	115	1	154	135	346	394	1.7	1.9
			2			374	423	2.1	2.3
			3			403	451	2.5	2.7
			4			431	480	2.9	3.1

◆ Technical Data

Method of Actuation	Solenoid Valve			Frequency Generator
Voltage	AC110V	AC220V	DC24V	--
Ampere	0.1A	0.1A	0.2A	--
Pneumatic Pressure	4-8kgf/cm ²			
Discharge Volume	0.01cc-0.08cc/stroke (Adjustable)			
Air Inlet	∅8			
Oil-Air Outlet	∅4, ∅6, ∅8 (∅8 Oil-Air outlet needs to be connected with ∅4x∅8 pipe-in-pipe.)			
Suitable Viscosity	Vegetable Oil, 22-68cSt@40°C			

◆ Pressure Chart (Reference Value)

Pneumatic Pressure (kgf/cm ²)	4	5	6	7	8
Air Consumption (L/min)	102	127	145	156	160

◆ Order Code

POM — 35 — 1 — 1 — 0 — ※

Tank Capacity		Oil-Air Outlet Number		Method of Actuation		Oil-Air Outlet Bore		Special Request	
01	2L Square Tank	1	1 Outlet	1	Frequency Generator	0	∅4	TC	Add a NC Contact Reed Switch
35	1000cc Cylindrical Tank	2	2 Outlets	A	Solenoid Valve, 110V	1	∅6	TO	Add a NO Contact Reed Switch
50	2000cc Cylindrical Tank	3	3 Outlets	C	Solenoid Valve, A20V	2	∅8	SC	Add a NC Contact Float Switch
		4	4 Outlets	K	Solenoid Valve, DC24V			SO	Add a NO Contact Float Switch

◆ Related Products



CLHA Resistance Type Grease Manual Lubricator



CLHA-35-R-D-1



CLHA-20-R-D-1

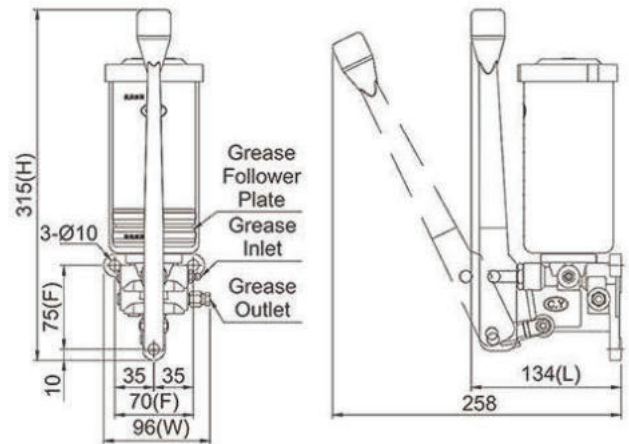

Dimensional Drawing of CLHA-20-R-D-1

◆ Features

1. CLHA discharges grease whenever its handle is pulled and pushed back.
2. CLHA has a grease follower plate tightly fit with the grease tank that pushes grease downwards while discharging so no grease remains inside the tank.
3. The outlet of CLHA can be on either the right side or the left side of the handle. A dual-outlet model is also available for selection.
4. CLHA is suitable for machines that do not require continuous lubrication, such as press machines and woodworking machines.

◆ Technical Data & Dimensional Data

Model	Tank Capacity	Mounting Bracket	Length (mm)	Width (mm)	Height (mm)	Mounting Hole Distance (mm)	Max. Discharge Volume	Max. Operating Pressure	Discharge Bore	Suitable Viscosity	N.W. (kg)
CLHA-10	300cc	X	134	96	315	70x75	2cc/stroke	100 Kgf/cm ²	Ø4 Ø6 Ø8 PT1/8	Grease NLGI 000-0	1.08
CLHA-20	600cc	X	134	96	315						1.11
CLHA-35	1000cc	O	166	113	340						1.61
CLHA-40	800cc	X	134	96	325						1.14
CLHA-50	2000cc	O	166	130	391						2.09

◆ Order Code

CLHA - 20 ——— R ——— D ——— 1

Tank Capacity	Capacity
10	300cc
20	600cc
35	1000cc
40	800cc
50	2000cc

Outlet Side	
L	Left Outlet
R	Right Outlet
D	Dual Outlets

Outlet Adapter	
D	Straight Adapter
H	Elbow Adapter

Discharge Bore			
0	Ø4	4	Ø8
1	Ø6	5	Ø8 W/Pressure Gauge
2	Ø4 W/Pressure Gauge	6	PT1/8
3	Ø6 W/Pressure Gauge	7	PT1/8 W/Pressure Gauge

◆ Related Products



P. 85

P. 81

P. 82

P. 83

P. 109

P. 111

P. 129

P. 124

P. 123



CLHA-25 Resistance Type Grease Tube Manual Lubricator



CLHA-25-R-D-1-A with Grease Tube

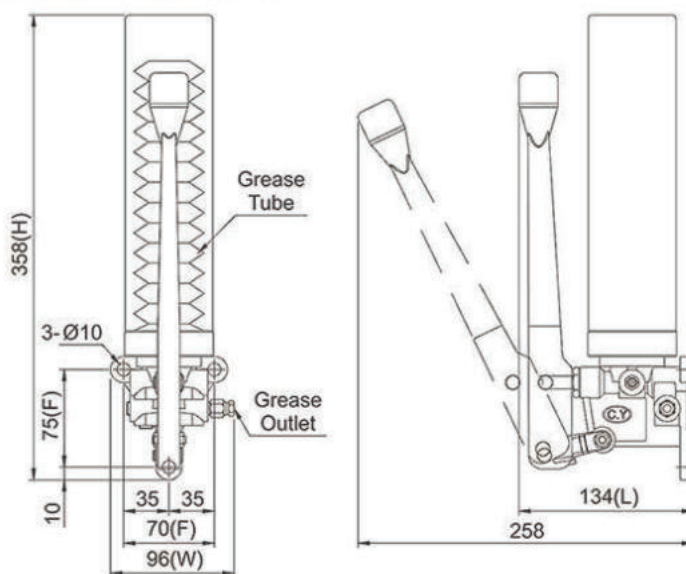

Dimensional Drawing of CLHA-25-R-D-1-A with Grease Tube

◆ Features

1. CLHA-25 discharges grease whenever its handle is pulled and pushed back.
2. The outlet of CLHA-25 can be on either the right side or the left side of the handle. A dual-outlet model is also available for selection.
3. CLHA-25 works with a 400cc disposable grease tube. When the grease is empty, replace CLHA-25 with a new grease tube. Standard CLHA-25 does not include a grease tube but is available upon request.
4. CLHA-25 has a protective cover that prevents the grease tube from being damaged.
5. CLHA-25 is suitable for machines that do not require continuous lubrication, such as press machines and woodworking machines.

◆ Technical Data & Dimensional Data

Model	Effective Capacity	Length (mm)	Width (mm)	Height (mm)	Mounting Hole Distance (mm)	Max. Discharge Volume	Max. Operating Pressure	Discharge Bore	Suitable Viscosity	N.W. (kg)
CLHA-25	400cc Grease Tube	134	96	358	70x75	2cc/stroke	100 Kg/cm ²	Ø4 Ø6 Ø8 PT1/8	Grease NLGI 0, 1	1.06

◆ Order Code

CLHA-25 — R — D — 1 — A — ※

Outlet Side		Outlet Adapter		Discharge Bore							Grease Tube Thread		Special Request	
L	Left Outlet	D	Straight Adapter	0	Ø4	1	Ø6	2	Ø4 W/Pressure Gauge	A	M15xP2.5	T0	Add a 400cc Grease Tube, NLGI 0	
R	Right Outlet	H	Elbow Adapter	3	Ø6 W/Pressure Gauge	4	Ø8	5	Ø8 W/Pressure Gauge	B	M15xP2.0	T1	Add a 400cc Grease Tube, NLGI 1	
D	Dual Outlets			6	PT1/8									
				7	PT1/8 W/Pressure Gauge									

※ The 400cc grease cartridges we supply are for the CLHA-25 models, and the grease tube thread is M15xP2.5.

◆ Related Products



CLHP Resistance Type Grease Manual Lubricator with Metal Spring



CLHP-40-R-D-1

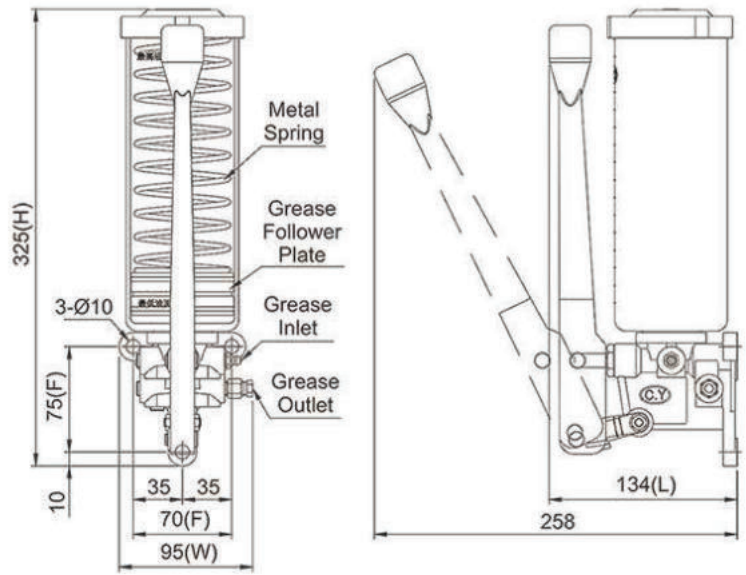

Dimensional Drawing of CLHP-40-R-D-1

◆ Features

1. CLHP discharges grease whenever its handle is pulled and pushed back.
2. The outlet of CLHP can be on either the right side or the left side of the handle. A dual-outlet model is also available for selection.
3. CLHP has a metal spring inside its grease tank, enabling it to work with thicker grease of the viscosity NLGI 1 and NLGI 2. Please refill grease from the grease inlet of CLHP to prevent air and impurities from entering the grease tank.
4. CLHP has a grease follower plate tightly fit with the grease tank that pushes grease downwards while discharging so no grease remains inside the tank.
5. CLHP is suitable for machines that do not require continuous lubrication, such as press machines and woodworking machines.

◆ Technical Data & Dimensional Data

Model	Effective Capacity	Length (mm)	Width (mm)	Height (mm)	Mounting Hole Distance (mm)	Max. Discharge Volume	Max. Operating Pressure	Discharge Bore	Suitable Viscosity	N.W. (kg)
CLHP-40	550cc	134	96	325	70x75	2cc/stroke	100 Kg/cm ²	Ø4	Grease NLGI 1, 2	1.50
CLHP-50	1500cc	166	130	391				Ø6		
								Ø8		
								PT1/8		2.82

◆ Order Code

CLHP — 40 — R — D — 1

Effective Capacity		Outlet Side			Outlet Adapter			Discharge Bore			
40	550cc	L	Left Outlet	D	Straight Adapter	0	Ø4	1	Ø6	2	Ø4 W/Pressure Gauge
50	1500cc	R	Right Outlet	H	Elbow Adapter	3	Ø6 W/Pressure Gauge	4	Ø8	5	Ø8 W/Pressure Gauge
		D	Dual Outlets			6	PT1/8	7	PT1/8 W/Pressure Gauge		

◆ Related Products



P. 85

P. 81

P. 82

P. 83

P. 109

P. 111

P. 129

P. 124

P. 123

KSC Resistance Type PLC Grease Electric Lubricator

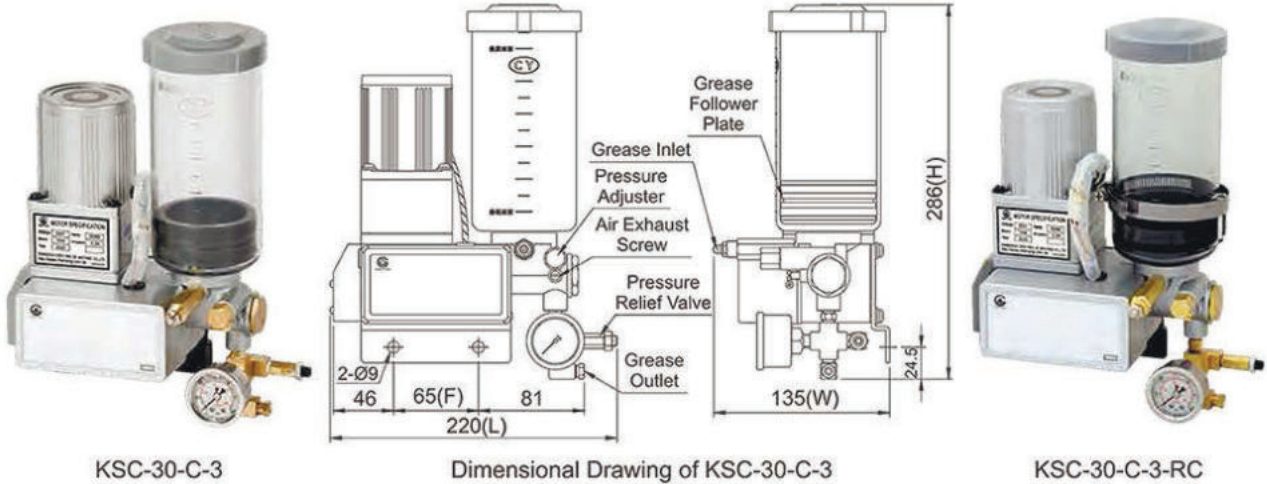

KSC-30-C-3

Dimensional Drawing of KSC-30-C-3

KSC-30-C-3-RC

◆ Features

1. The operation and interval time of KSC are controlled by PLC.
2. KSC has a pressure gauge that enables the user to check the operating pressure easily.
3. A magnetic level switch can be added to KSC on request to detect the grease level automatically.
4. Please refill grease from the grease inlet of KSC to prevent air and impurities from entering the grease tank.

◆ Order Code

KSC — 30 — C — 3 — ※

Tank Capacity	
30	600cc
35	1000cc
40	800cc
50	2000cc

Voltage	
A	AC110V
C	AC220V
K	DC24V

Discharge Bore	
0	∅4
1	∅6
2	∅4 W/Pressure Gauge
3	∅6 W/Pressure Gauge
4	∅8
5	∅8 W/Pressure Gauge
6	PT1/8
7	PT1/8 W/Pressure Gauge

Special Request	
RC	Add a NC Contact Magnetic Level Switch
RO	Add a NO Contact Magnetic Level Switch

◆ Dimensional Data

Model	Tank Capacity	Length (mm)	Width (mm)	Height (mm)	Mounting Hole Distance (mm)	N.W. (kg)
KSC-30	600cc	220	135	286	65	3.68
KSC-35	1000cc	220	161	301		4.19
KSC-40	800cc	220	135	340		3.71
KSC-50	2000cc	220	161	386		4.36

◆ Technical Data

	AC110V	AC220V	DC24V
Voltage	AC110V	AC220V	DC24V
Motor Power	15W	15W	20W
Ampere	0.5A	0.2A	0.4A
Hertz	50/60Hz Compatible		--
Max. Discharge Volume	15cc/min		
Max. Operating Pressure	150kgf/cm ²		
Discharge Bore	∅4, ∅6, ∅8, PT1/8		
Suitable Viscosity	Grease, NLGI 000-0		

◆ Wiring Diagram

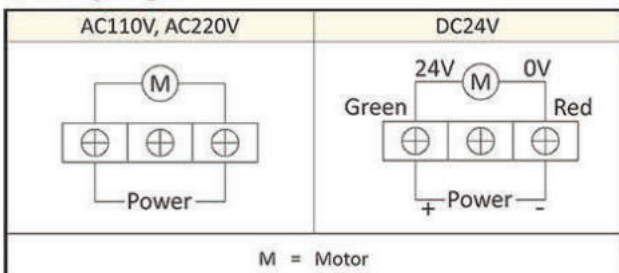

◆ Related Products



KSCP Resistance Type **PLC** Grease Electric Lubricator with Metal Spring



KSCP-40-C-3

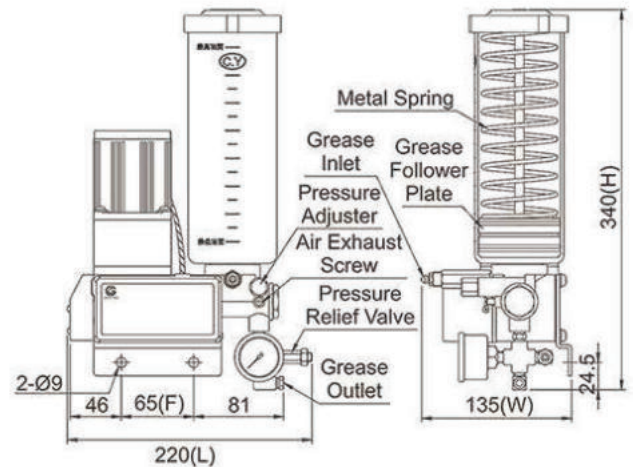

Dimensional Drawing of KSCP-40-C-3

◆ Features

1. The operation and interval time of KSCP are controlled by PLC.
2. KSCP has a pressure gauge that enables the user to check the operating pressure easily.
3. KSCP has a metal spring inside its grease tank, enabling it to work with thicker grease of the viscosity NLGI 1 and NLGI 2.
4. A magnetic level switch can be added to KSCP on request to detect the grease level automatically.
5. Please refill grease from the grease inlet of KSCP to prevent air and impurities from entering the grease tank.

◆ Order Code

KSCP — 30 — C — 3 — ※

Effective Capacity	
40	550cc
50	1500cc

Voltage	
A	AC110V
C	AC220V
K	DC24V

Discharge Bore	
0	∅4
1	∅6
2	∅4 W/Pressure Gauge
3	∅6 W/Pressure Gauge
4	∅8
5	∅8 W/Pressure Gauge
6	PT1/8
7	PT1/8 W/Pressure Gauge

Special Request	
RC	Add a NC Contact Magnetic Level Switch
RO	Add a NO Contact Magnetic Level Switch

◆ Dimensional Data

Model	Effective Capacity	Length (mm)	Width (mm)	Height (mm)	Mounting Hole Distance (mm)	N.W. (kg)
KSCP-40	550cc	220	135	340	65	4.33
KSCP-50	1500cc	220	161	386		5.55

◆ Technical Data

Voltage	AC110V	AC220V	DC24V
Motor Power	15W	15W	20W
Ampere	0.5A	0.2A	0.4A
Hertz	50/60Hz Compatible		--
Max. Discharge Volume	15cc/min		
Max. Operating Pressure	150kgf/cm ²		
Discharge Bore	∅4, ∅6, ∅8, PT1/8		
Suitable Viscosity	Grease, NLGI 1, 2		

◆ Wiring Diagram

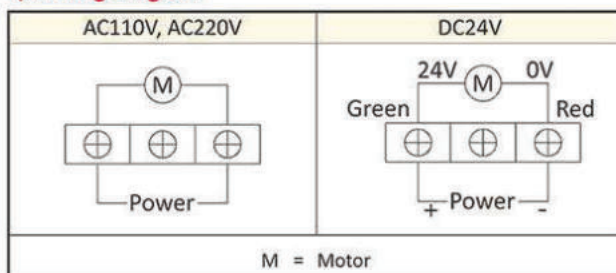

◆ Related Products



P. 85

P. 81

P. 82

P. 83

P. 109

P. 111

P. 129

P. 124

P. 123

KGA / KGAP Resistance Type PLC Grease Electric Lubricator



KGA-35-K-1

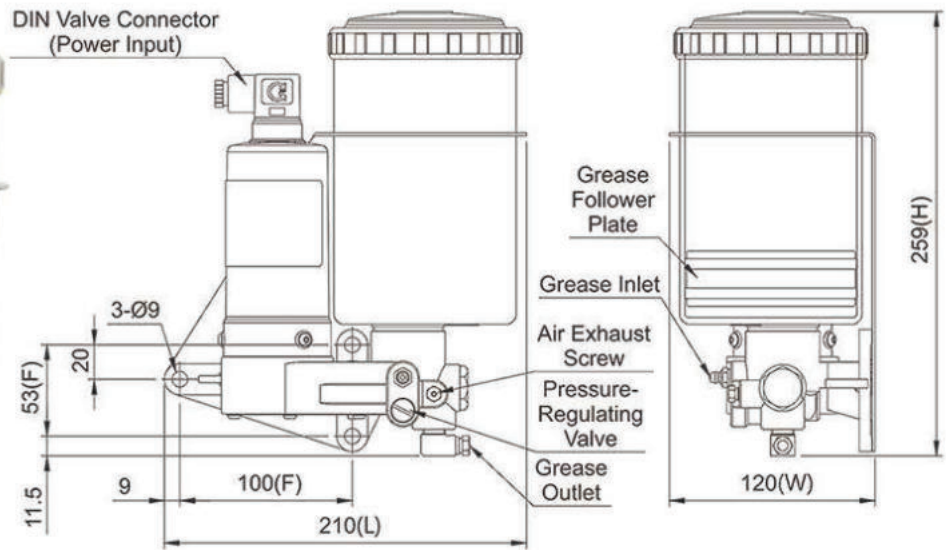

Dimensional Drawing of KGA-35-K-1



KGAP-40-K-1

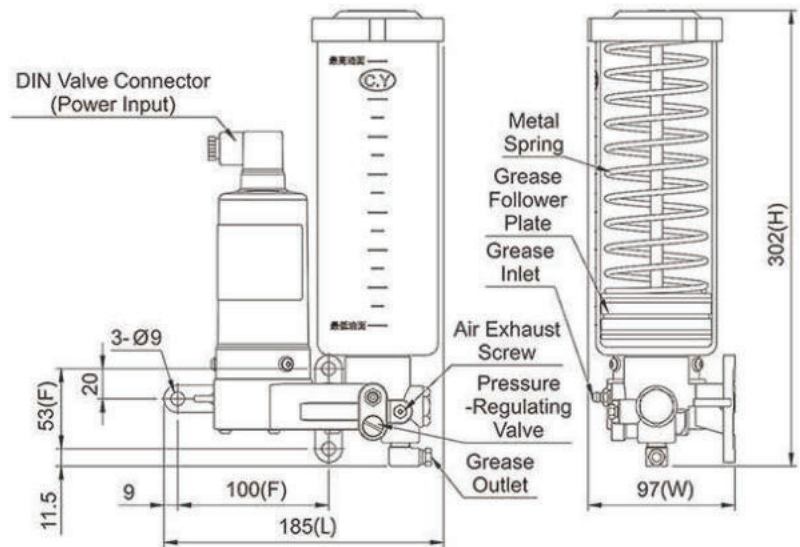

Dimensional Drawing of KGAP-40-K-1

◆ Features

1. The operation and interval time of KGA and KGAP are controlled by PLC.
2. A magnetic level switch can be added to KGA and KGAP on request to detect the grease level automatically.
3. Please refill grease from the grease inlet of KGA and KGAP to prevent air and impurities from entering the grease tank.
4. KGAP has a metal spring inside its grease tank, enabling it to work with thicker grease viscosity NLGI 1 and NLGI 2, while KGA is only available for NLGI 000 to 0.

◆ Dimensional Data (KGA)

Model	Tank Capacity	Length (mm)	Width (mm)	Height (mm)	Mounting Hole Distance (mm)	N.W. (kg)
KGA-30	600cc	185	97	247	100x53	1.69
KGA-40	800cc	185	97	302		1.71
KGA-35	1000cc	210	120	259		2.12

◆ Dimensional Data (KGAP)

Model	Effective Capacity	Length (mm)	Width (mm)	Height (mm)	Mounting Hole Distance (mm)	N.W. (kg)
KGAP-40	550cc	185	97	302	100x53	2.07

KGA / KGAP Resistance Type Grease Electric Lubricator

PLC

◆ Technical Data

Motor Power	Voltage	Ampere	Max. Discharge Volume	Max. Operating Pressure	Discharge Bore	Suitable Viscosity
35±3W	DC24V	2.1A	16cc/min	150kgf/cm ²	∅6, ∅8	KGA: Grease, NLGI 000-0 KGAP: Grease, NLGI 1, 2

◆ Wiring Diagram

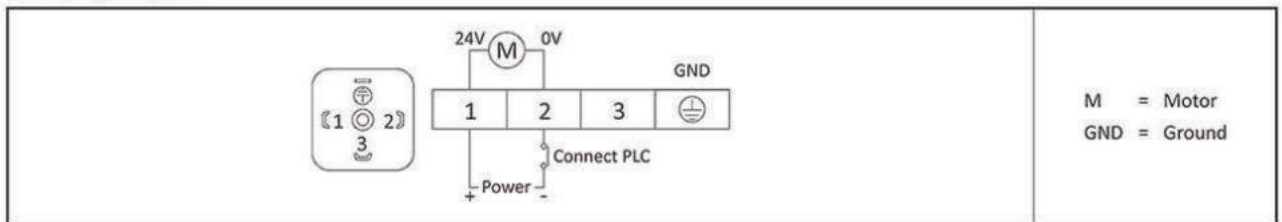

◆ Order Code (KGA)

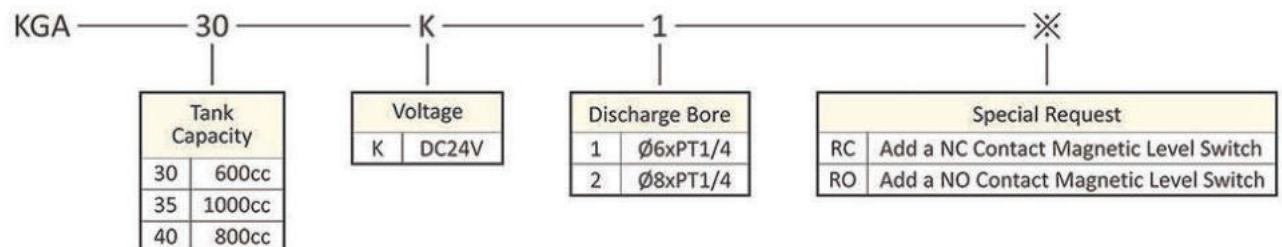

◆ Order Code (KGAP)

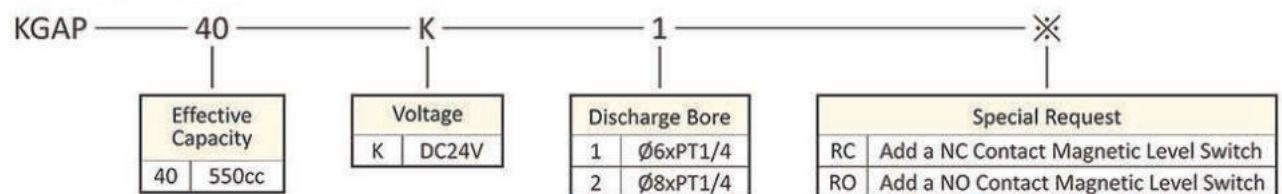

◆ Related Products



KGC / KGCP Resistance Type Grease Electric Lubricator

PLC

KGC / KGCP Resistance Type Grease Electric Lubricator



KGC-35-C-3



KGCP-50-C-3



KGCP-07-C-3 with Grease Cartridge

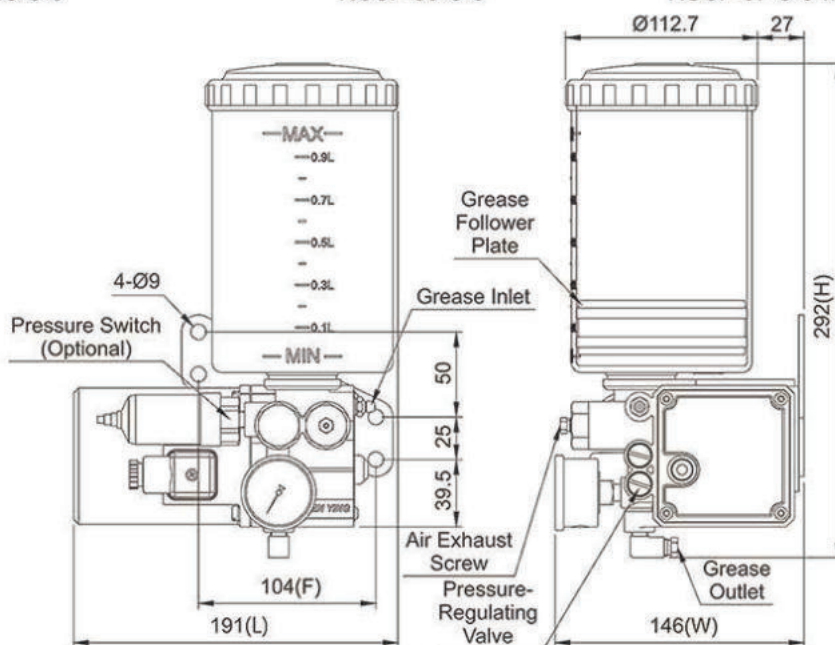

Dimensional Drawing of KGC-35-C-3-PC

◆ Features

1. The operation and interval time of KGC and KGCP are controlled by PLC.
2. KGC and KGCP have pressure gauges that enables the users to check the operating pressure easily.
3. 1Ø110V, 1Ø220V, and DC24V models have feed-grease buttons, which can be used as manual grease feeding for less than 3 minutes to avoid overloading the motor.
4. 1Ø110V and 1Ø220V models have thermal controls that will shut down the motors for about 5 minutes when the motors are overheated.
5. A 60kgf/cm² socket pressure switch can be added to KGC and KGCP on request to detect the operating pressure automatically.
6. A magnetic level switch can be added to KGC and KGCP on request to detect the grease level automatically.
7. For KGC and KGCP-50, refill grease from the grease inlet to prevent air and impurities from entering the grease tank.
8. KGCP-07 works with a 700cc disposable grease cartridge. When the grease is empty, replace KGCP-07 with a new grease cartridge. Standard KGCP-07 does not include a grease cartridge but is available upon request.

◆ Dimensional Data (KGC)

Model	Tank Capacity	Length (mm)	Width (mm)	Height (mm)	Mounting Hole Distance (mm)	N.W. (kg)
KGC-35	1000cc	191	146	292	104	4.07
KGC-50	2000cc	198	151	376		4.55

◆ Dimensional Data (KGCP)

Model	Effective Capacity	Length (mm)	Width (mm)	Height (mm)	Mounting Hole Distance (mm)	N.W. (kg)
KGCP-50	1500cc	198	151	376	104	5.55
KGCP-07	700cc Grease Cartridge	195	156	298		4.12

KGC / KGCP Resistance Type Grease Electric Lubricator PLC

◆ Technical Data

Voltage	1Ø110V	1Ø220V	3Ø220V	3Ø380V	DC24V
Motor Output	60W	80W	60W	60W	60W
Ampere	1.80A	1.00A	1.00A	1.00A	1.65A
Feed-Grease Button	O	O	X	X	O
Motor Thermal Control	O	O	X	X	X
Hertz	50/60Hz Compatible				--
Max. Discharge Volume	30cc/min				35cc/min
Max. Operating Pressure	100kgf/cm ²				
Discharge Bore	Ø6, Ø8, PT1/8				
Suitable Viscosity	KGC: Grease, NLGI 000-0 KGCP-50: Grease, NLGI 1, 2 KGCP-07: Grease, NLGI 000-1				

◆ Wiring Diagram

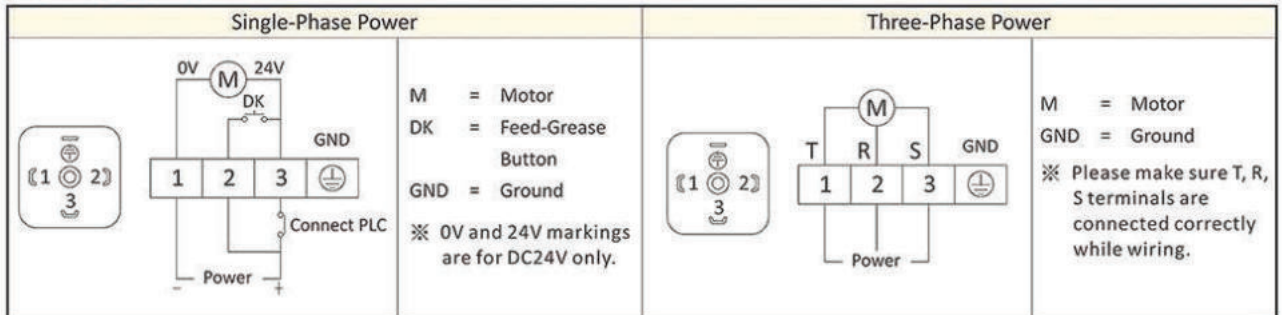

◆ Order Code (KGC)

KGC — 35 — C — 3 — ※

Tank Capacity	Voltage	Discharge Bore	Special Request
35 1000cc	A 1Ø110V	1 Ø6	PC Add a NC Contact Pressure Switch
50 2000cc	C 1Ø220V	3 Ø6 W/Pressure Gauge	PO Add a NO Contact Pressure Switch
	K DC24V	4 Ø8	RC Add a NC Contact Magnetic Level Switch
	M 3Ø220V	5 Ø8 W/Pressure Gauge	RO Add a NO Contact Magnetic Level Switch
	N 3Ø380V	6 PT1/8	
		7 PT1/8 W/Pressure Gauge	

◆ Order Code (KGCP)

KGCP — 07 — C — 3 — ※

Effective Capacity	Voltage	Discharge Bore	Special Request
50 1500cc	A 1Ø110V	1 Ø6	PC Add a NC Contact Pressure Switch
07 700cc Grease Cartridge	C 1Ø220V	3 Ø6 W/Pressure Gauge	PO Add a NO Contact Pressure Switch
	K DC24V	4 Ø8	RC Add a NC Contact Magnetic Level Switch
	M 3Ø220V	5 Ø8 W/Pressure Gauge	RO Add a NO Contact Magnetic Level Switch
	N 3Ø380V	6 PT1/8	
		7 PT1/8 W/Pressure Gauge	

※ Please refer to the 700cc Grease Cartridge catalog if you need to purchase one.

◆ Related Products



KGB / KGBP Pressure-Relief Type Grease Electric Lubricator

PLC



KGB-35-C-5



KGBP-07-C-5 with Grease Cartridge

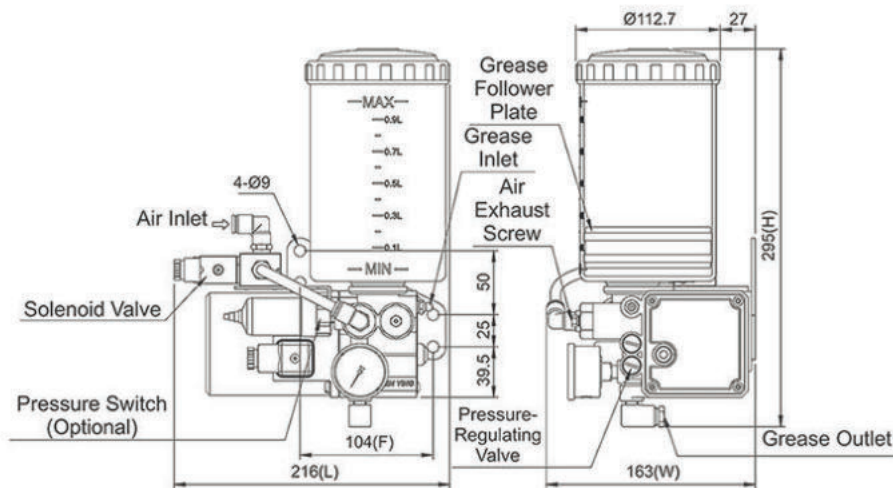

Dimensional Drawing of KGB-35-C-5-PC

◆ Features

1. The operation and interval time of KGB and KGBP are controlled by PLC. KGB and KGBP require 4.5-8kgf/cm² pneumatic pressure supply for the pressure-relief function.
2. KGB and KGBP have to work with CFB volume type grease distributors to deliver the metered quantity of grease to the lubrication points.
3. KGB and KGBP have pressure gauges that enable the user to check the operating pressure easily.
4. KGB and KGBP have feed-grease buttons, which can be used as manual grease feeding for less than 3 minutes to avoid overloading the motor.
5. 1Ø110V and 1Ø220V models have thermal controls that will shut down the motors for about 5 minutes when the motor is overheated.
6. A 60kgf/cm² socket pressure switch can be added to KGB and KGBP on request to detect the operating pressure automatically.
7. A magnetic level switch can be added to KGB and KGBP on request to detect the grease level automatically.
8. For KGB, refill grease from the grease inlet to prevent air and impurities from entering the grease tank.
9. KGBP-07 works with a 700cc disposable grease cartridge. When the grease is empty, replace KGBP-07 with a new grease cartridge. Standard KGBP-07 does not include a grease cartridge but is available upon request.

◆ Dimensional Data (KGB)

Model	Tank Capacity	Length (mm)	Width (mm)	Height (mm)	Mounting Hole Distance (mm)	N.W. (kg)
KGB-35	1000cc	216	163	295	104	4.37
KGB-50	2000cc	224	163	380		5.85

◆ Dimensional Data (KGBP)

Model	Effective Capacity	Length (mm)	Width (mm)	Height (mm)	Mounting Hole Distance (mm)	N.W. (kg)
KGBP-07	700cc Grease Cartridge	220	163	302	104	4.42

KGV Resistance Type **PLC** Fluid Grease Electric Lubricator



KGV-03-C-40-3

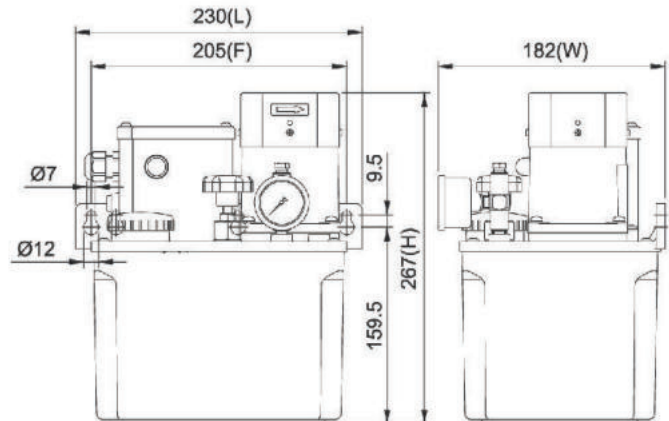

Dimensional Drawing of KGV-03-C-40-3

◆ Features

1. The operation and interval time of KGV are controlled by PLC.
2. KGV has a pressure-regulating valve that enables the user to adjust the operating pressure.
3. KGV has a feed-grease button, which can be used as manual grease feeding for less than 3 minutes to avoid overloading the motor.
4. A 20kgf/cm² socket pressure switch can be added to KGV on request to detect the operating pressure automatically.
5. A capacitive level switch can be added to KGV on request to detect the grease level automatically.
6. The gear pump of KGV is made of special aluminum alloy and assembled with a 40W induction motor to provide stable output pressure, low operating noise, and long service life.
7. The induction motor has a fan that can reduce the temperature and prolong the service life of KGV.

◆ Order Code

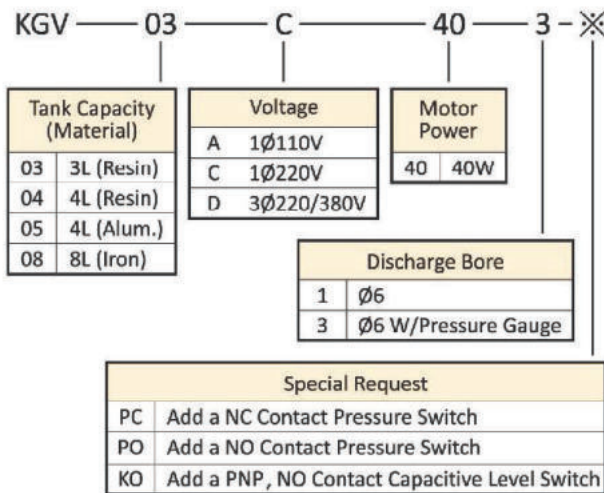

◆ Dimensional Data

Tank Capacity	Tank Material	Length (mm)	Width (mm)	Height (mm)	Mounting Hole Distance (mm)	N.W. (kg)
3L	Resin	230	182	267	205	5.09
4L	Resin	288	162	278	250	5.69
4L	Alum.	297	170	276	95x280	6.64
8L	Iron	355	201	299	95x338	9.39

◆ Technical Data

Voltage	1 ϕ 110V	1 ϕ 220V	3 ϕ 220/380V
Ampere	0.75A	0.50A	0.40A
Motor Power	40W		
Hertz	50/60Hz Compatible		
Max. Discharge Volume	170cc/min		
Max. Operating Pressure	40kgf/cm ²		
Discharge Bore	ϕ 6		
Suitable Viscosity	Grease, NLGI 000, 00 (NLGI 00 is suitable for the model with 3L resin tank only.)		

◆ Wiring Diagram

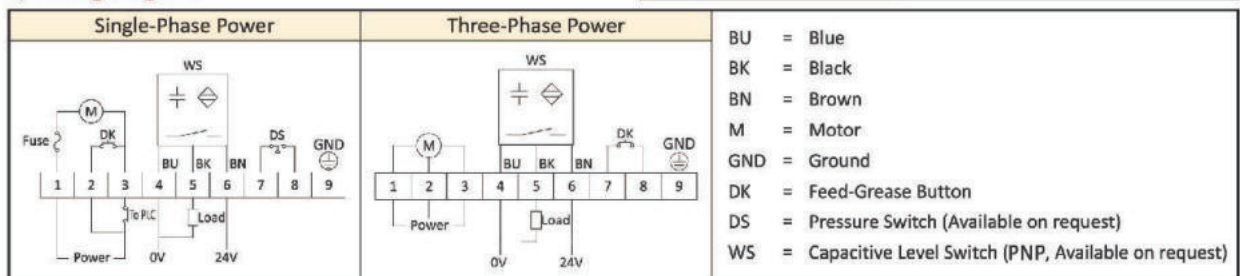

※ A standard dual-voltage motor is connected for low voltage. Please specify if you need it to be connected for high voltage when placing an order.

◆ Related Products



P. 85

P. 81

P. 82

P. 83

P. 109

P. 111

P. 129

P. 124

P. 123

KAC / KACP Resistance Type Grease Electric Lubricator

PLC

KAC / KACP Resistance Type Grease Electric Lubricator



KAC-35-K-3-PC-RC

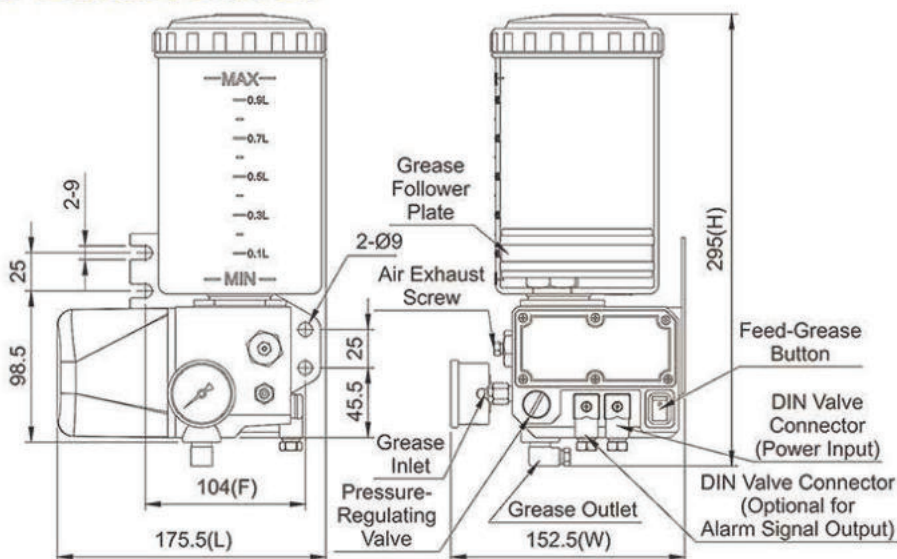

Dimensional Drawing of KAC-35-K-3-PC-RC



KACP-07-K-3-PC-RC with Grease Cartridge

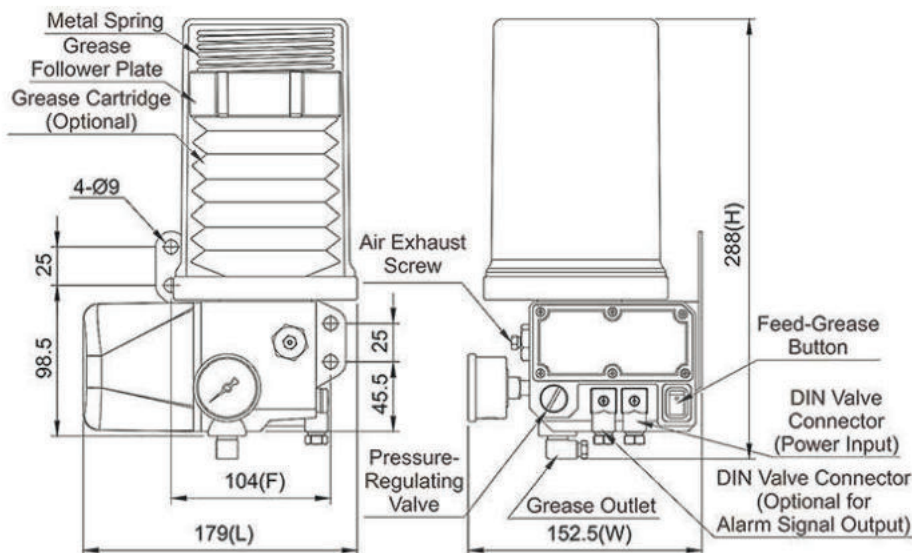

Dimensional Drawing of KACP-07-K-3-PC-RC with Grease Cartridge

◆ Features

1. The operation and interval time of KAC and KACP are controlled by PLC.
2. KAC and KACP have pressure gauges that enable the users to check the operating pressure easily.
3. KAC and KACP have feed-grease buttons, which can be used as manual grease feeding for less than 3 minutes to avoid overloading the motor.
4. A 60kgf/cm² socket pressure switch can be added to KAC and KACP on request to detect the operating pressure automatically.
5. A magnetic level switch can be added to KAC and KACP on request to detect the grease level automatically.
6. For KAC, refill grease from the grease inlet to prevent air and impurities from entering the grease tank.
7. KACP-07 works with a 700cc disposable grease cartridge. When the grease is empty, replace KACP-07 with a new grease cartridge. Standard KACP-07 does not include a grease cartridge but is available upon request.

◆ Dimensional Data (KAC)

Model	Tank Capacity	Length (mm)	Width (mm)	Height (mm)	Mounting Hole Distance (mm)	N.W. (kg)
KAC-40	800cc	172.0	152.5	338	104	2.12
KAC-35	1000cc	175.5	152.5	295		2.21
KAC-50	2000cc	182.5	152.5	379		2.55

◆ Dimensional Data (KACP)

Model	Effective Capacity	Length (mm)	Width (mm)	Height (mm)	Mounting Hole Distance (mm)	N.W. (kg)
KACP-07	700cc Grease Cartridge	179.0	152.5	288	104	2.29

KAC / KACP Resistance Type Grease Electric Lubricator

PLC

◆ Technical Data

Motor Power	Voltage	Ampere	Max. Discharge Volume	Max. Operating Pressure	Discharge Bore	Suitable Viscosity
35±3W	DC24V	3.0A	10cc/min	100kgf/cm ²	∅6, ∅8	Grease, NLGI 000-0

◆ Wiring Diagram

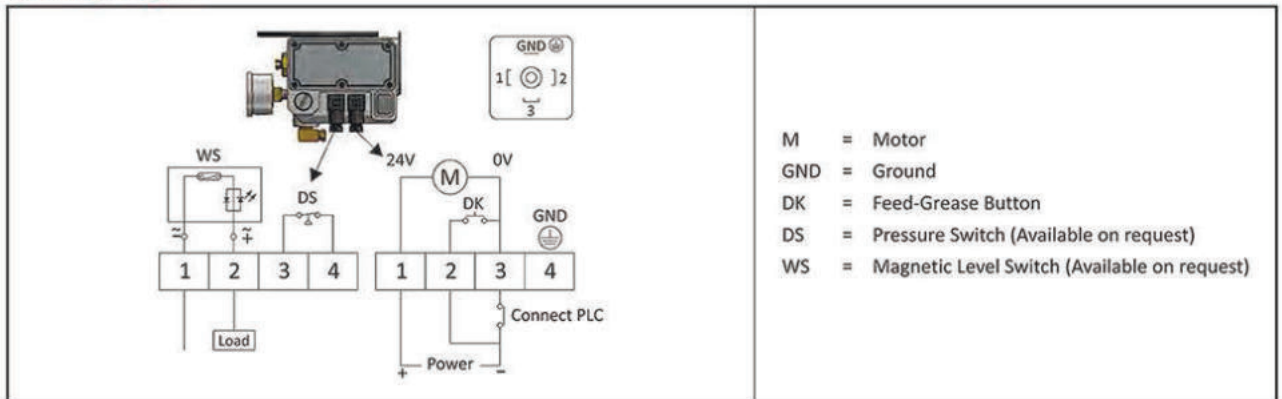

◆ Order Code (KAC)

KAC — 35 — K — 3 — ※

Tank Capacity		Voltage	Discharge Bore		Special Request		
40	800cc	K	DC24V	1	∅6	PC	Add a NC Contact Pressure Switch
35	1000cc			3	∅6 W/Pressure Gauge	PO	Add a NO Contact Pressure Switch
50	2000cc			4	∅8	RC	Add a NC Contact Magnetic Level Switch
				5	∅8 W/Pressure Gauge	RO	Add a NO Contact Magnetic Level Switch

◆ Order Code (KACP)

KACP — 07 — K — 3 — ※

Effective Capacity		Voltage	Discharge Bore		Special Request		
07	700cc Grease Cartridge	K	DC24V	1	∅6	PC	Add a NC Contact Pressure Switch
				3	∅6 W/Pressure Gauge	PO	Add a NO Contact Pressure Switch
				4	∅8	RC	Add a NC Contact Magnetic Level Switch
				5	∅8 W/Pressure Gauge	RO	Add a NO Contact Magnetic Level Switch

※ Please refer to the 700cc Grease Cartridge catalog if you need to purchase one.

◆ Related Products



KSB Resistance Type Grease Electric Lubricator **Timer**



KSB-30-180-C-3

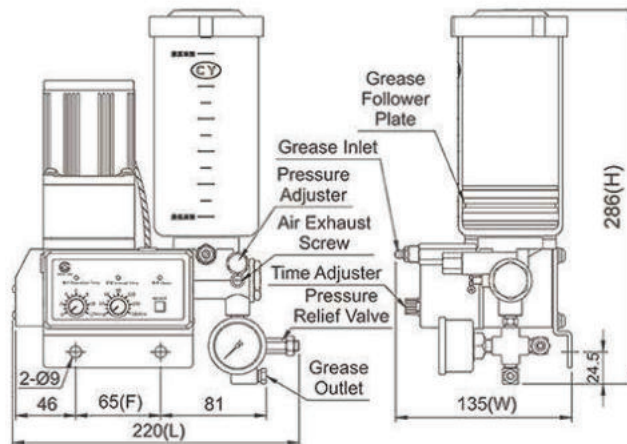

Dimensional Drawing of KSB-30-180-C-3



KSB-40-180-C-3-RC

◆ Features

1. KSB has a timer that controls its operation and interval time.
2. KSB has a pressure gauge that enables the user to check the operating pressure easily.
3. A magnetic level switch can be added to KSB on request to detect the grease level automatically.
4. Please refill grease from the grease inlet of KSB to prevent air and impurities from entering the grease tank.

◆ Order Code

KSB — 30 — 180 — C — 3 — ✖

Tank Capacity	
30	600cc
35	1000cc
40	800cc
50	2000cc

Interval Time	
180	180min.
360	360min.

Voltage	
A	AC110V
C	AC220V
K	DC24V

Discharge Bore	
0	Ø4
1	Ø6
2	Ø4 W/Pressure Gauge
3	Ø6 W/Pressure Gauge
4	Ø8
5	Ø8 W/Pressure Gauge
6	PT1/8
7	PT1/8 W/Pressure Gauge

Special Request	
RC	Add a NC Contact Magnetic Level Switch
RO	Add a NO Contact Magnetic Level Switch

◆ Dimensional Data

Model	Tank Capacity	Length (mm)	Width (mm)	Height (mm)	Mounting Hole Distance (mm)	N.W. (kg)
KSB-30	600cc	220	135	286	65	3.70
KSB-35	1000cc	220	161	301		4.25
KSB-40	800cc	220	135	340		3.73
KSB-50	2000cc	220	161	386		4.82

◆ Technical Data

Operation Time	3 sec. to 12 min.		
Interval Time	1-180 min., 1-360 min.		
Voltage	AC110V	AC220V	DC24V
Motor Power	15W	15W	20W
Ampere	0.5A	0.2A	0.4A
Hertz	50/60Hz Compatible		
Max. Discharge Volume	15cc/min		
Max. Operating Pressure	150kgf/cm ²		
Discharge Bore	Ø4, Ø6, Ø8, PT1/8		
Suitable Viscosity	Grease, NLGI 000-0		

◆ Wiring Diagram

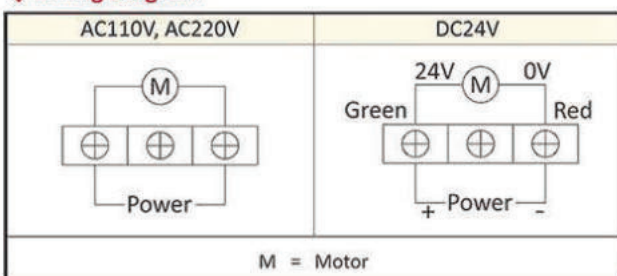

◆ Related Products



P. 85

P. 81

P. 82

P. 83

P. 109

P. 111

P. 129

P. 124

P. 123

KSBP Resistance Type Grease Electric Lubricator with Metal Spring Timer



KSBP-40-180-C-3

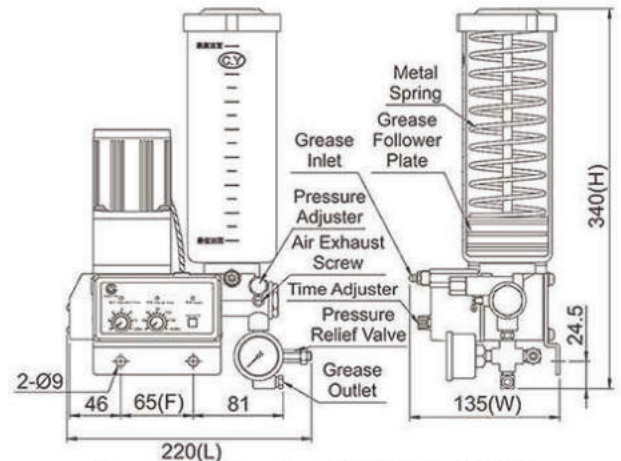

Dimensional Drawing of KSBP-40-180-C-3

◆ Features

1. KSBP has a timer that controls its operation and interval time.
2. KSBP has a pressure gauge that enables the user to check the operating pressure easily.
3. KSBP has a metal spring inside its grease tank, enabling it to work with thicker grease of the viscosity NLGI 1 and NLGI 2.
4. A magnetic level switch can be added to KSBP on request to detect the grease level automatically.
5. Please refill grease from the grease inlet of KSBP to prevent air and impurities from entering the grease tank.

◆ Order Code

KSBP - 40 - 180 - C - 3

Effective Capacity	
40	550cc
50	1500cc

Interval Time	
180	180min.
360	360min.

Voltage	
A	AC110V
C	AC220V
K	DC24V

Discharge Bore	
0	∅4
1	∅6
2	∅4 W/Pressure Gauge
3	∅6 W/Pressure Gauge
4	∅8
5	∅8 W/Pressure Gauge
6	PT1/8
7	PT1/8 W/Pressure Gauge

Special Request	
RC	Add a NC Contact Magnetic Level Switch
RO	Add a NO Contact Magnetic Level Switch

◆ Dimensional Data

Model	Effective Capacity	Length (mm)	Width (mm)	Height (mm)	Mounting Hole Distance (mm)	N.W. (kg)
KSBP-40	550cc	220	135	340	65	4.10
KSBP-50	1500cc	220	161	386		5.47

◆ Technical Data

Operation Time	3 sec. to 12 min.		
Interval Time	1-180 min., 1-360 min.		
Voltage	AC110V	AC220V	DC24V
Motor Power	15W	15W	20W
Ampere	0.5A	0.2A	0.4A
Hertz	50/60Hz Compatible		--
Max. Discharge Volume	15cc/min		
Max. Operating Pressure	150kgf/cm ²		
Discharge Bore	∅4, ∅6, ∅8, PT1/8		
Suitable Viscosity	Grease, NLGI 1, 2		

◆ Wiring Diagram

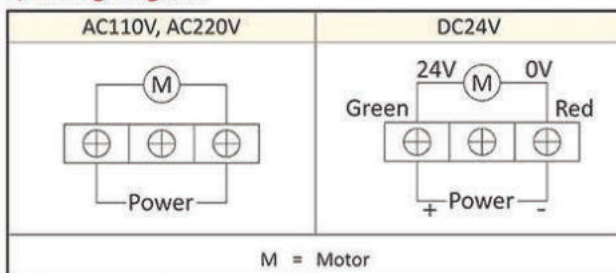

◆ Related Products



KGN / KGNP Resistance Type Grease Electric Lubricator

Timer



KGN-35-2-C-3-PC



KGN-50-2-C-3



KGNP-07-2-C-3 with Grease Cartridge

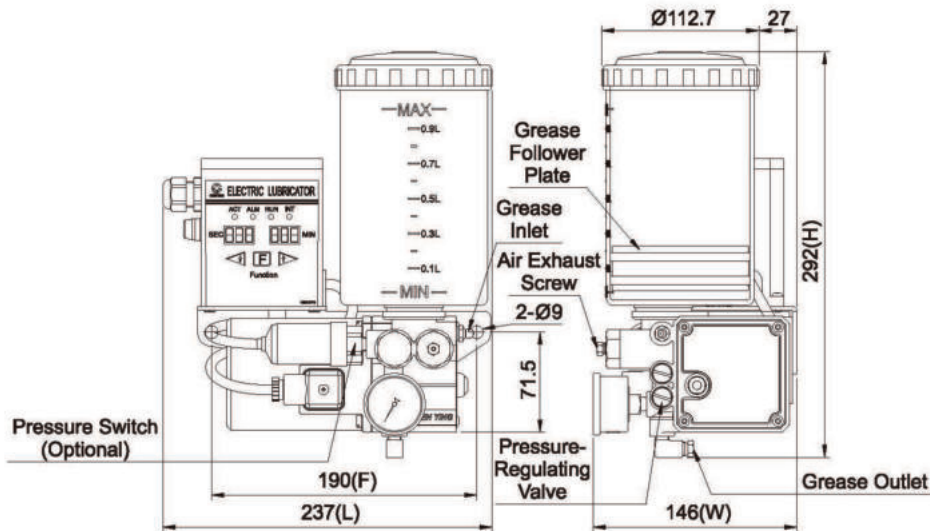

Dimensional Drawing of KGN-35-2-C-3-PC

◆ Features

1. KGN and KGNP have timers that control the operation and interval time.
2. There are four indicators on the control box, operation (ACT), alarm (ALM), immediate lubrication (RUN), and interval (INT).
3. KGN and KGNP have pressure gauges that enable the users to check the operating pressure easily.
4. KGN and KGNP have feed-grease buttons (F button), which can be used as manual grease feeding for less than 3 minutes to avoid overloading the motor.
5. KGN and KGNP have thermal controls that shut down the motor for about 5 minutes when the motor is overheated.
6. A 60kgf/cm² socket pressure switch can be added to KGN and KGNP on request to detect the operating pressure automatically.
7. A magnetic level switch can be added to KGN and KGNP on request to detect the grease level automatically.
8. The lubricator, which adds a pressure switch or a magnetic level switch, has abnormal pressure or low grease level; the build-in buzzer of the control box will send an alarm sound.
9. Please refill grease from the grease inlet to prevent air and impurities from entering the grease tank.
10. KGNP-07 works with a 700cc disposable grease cartridge. When the grease is empty, replace KGNP-07 with a new grease cartridge. Standard KGCP-07 does not include a grease cartridge but is available upon request.

◆ Dimensional Data (KGN)

Model	Tank Capacity	Length (mm)	Width (mm)	Height (mm)	Mounting Hole Distance (mm)	N.W. (kg)
KGN-35	1000cc	237	146	292	190	4.65
KGN-50	2000cc	245	151	376		5.11

◆ Dimensional Data (KGNP)

Model	Effective Capacity	Length (mm)	Width (mm)	Height (mm)	Mounting Hole Distance (mm)	N.W. (kg)
KGNP-50	1500cc	245	151	376	190	6.11
KGNP-07	700cc Grease Cartridge	241	156	298		4.70

KGN / KGNP Resistance Type Grease Electric Lubricator

KGN / KGNP Resistance Type Grease Electric Lubricator Timer

◆ Technical Data

Operation Time	1-999 sec.		
Interval Time	1-999 sec., 1-999 min.		
Voltage	110V	220V	
Motor Output	60W	80W	
Ampere	1.8A	1.0A	
Hertz	50/60Hz Compatible		
Max. Discharge Volume	30cc/min		
Max. Operating Pressure	100kgf/cm ²		
Discharge Bore	Ø6, Ø8, PT1/8		
Suitable Viscosity	KGN: Grease, NLGI 000-0 KGNP-50: Grease, NLGI 1, 2 KGNP-07: Grease, NLGI 000-1		

◆ Wiring Diagram

Abnormal Output			Ground	Power
NO(A)	NC(B)	COM	GND(P.E)	POWER
⊕	⊕	⊕	⊕	⊕ ⊕

◆ Order Code (KGN)

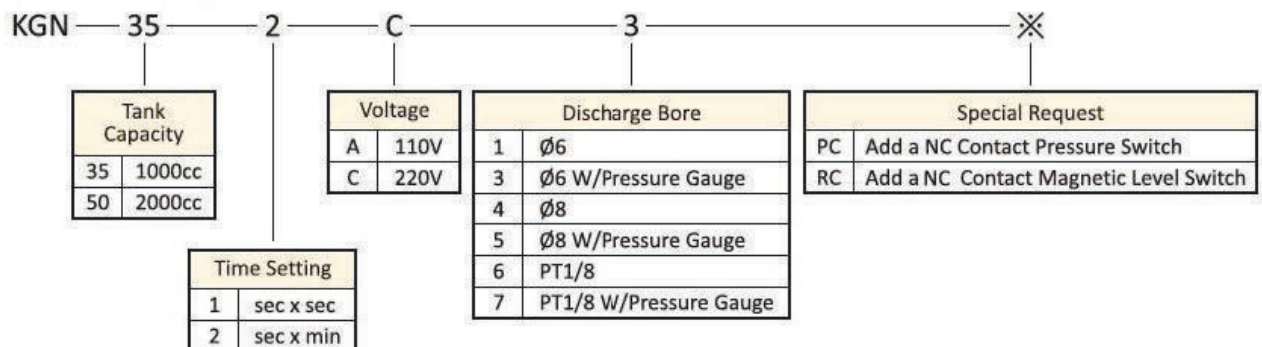

◆ Order Code (KGNP)

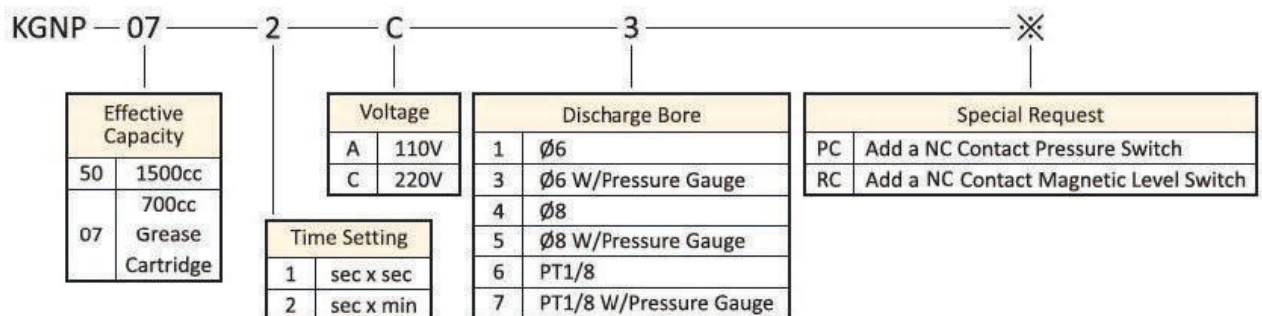

✕ Please refer to the 700cc Grease Cartridge catalog if you need to purchase one.

◆ Related Products



P. 85

P. 81

P. 82

P. 83

P. 109

P. 111

P. 80

P. 124

P. 123

KGNV Resistance Type **Timer** Fluid Grease Electric Lubricator



KGNV-03-C-40-3

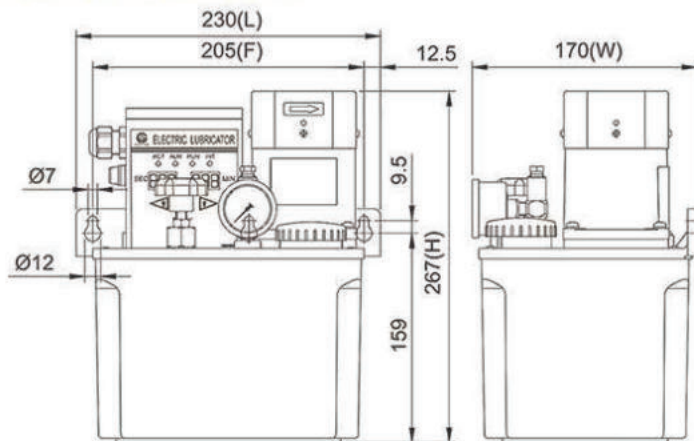

Dimensional Drawing of KGNV-03-C-40-3

◆ Features

1. KGNV has a timer that controls the operation and interval time.
2. There are four indicators on the control box, operation (ACT), alarm (ALM), immediate lubrication (RUN), and interval (INT).
3. KGNV has a pressure-regulating valve that enables the user to adjust the operating pressure.
4. KGNV has a feed-grease button (F button), which can be used as manual grease feeding for less than 3 minutes to avoid overloading the motor.
5. A 20kgf/cm² socket pressure switch can be added to KGNV on request to detect the operating pressure automatically.
6. The gear pump of KGNV is made of special aluminum alloy and assembled with a 40W induction motor to provide stable output pressure, low operating noise, and long service life.
7. The induction motor has a fan that can reduce the temperature and prolong the service life of KGNV.

◆ Order Code

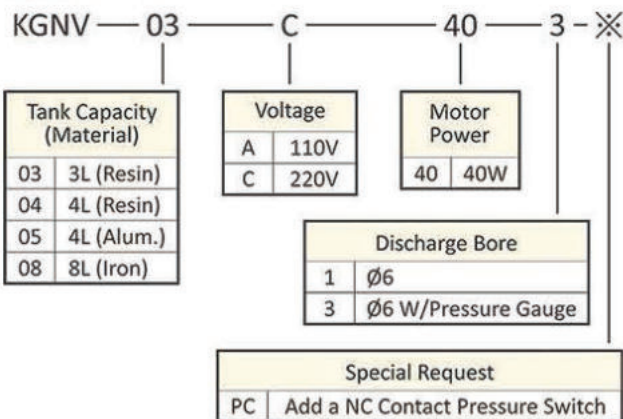

◆ Dimensional Data

Tank Capacity	Tank Material	Length (mm)	Width (mm)	Height (mm)	Mounting Hole Distance (mm)	N.W. (kg)
3L	Resin	230	170	267	205	5.25
4L	Resin	277	162	278	250	5.85
4L	Alum.	297	170	276	95x280	6.85
8L	Iron	355	201	299	95x338	9.59

◆ Technical Data

Operation Time	1-999 sec.	
Interval Time	1-999 min.	
Voltage	110V	220V
Ampere	0.75A	0.50A
Motor Power	40W	
Hertz	50/60Hz Compatible	
Max. Discharge Volume	170cc/min	
Max. Operating Pressure	40kgf/cm ²	
Discharge Bore	∅6	
Suitable Viscosity	Grease, NLGI 000, 00 (NLGI 00 is suitable for the model with 3L resin tank only.)	

◆ Wiring Diagram

Abnormal Output			Ground	Power
NO(A)	NC(B)	COM	GND(P.E)	POWER
⊕	⊕	⊕	⊕	⊕

◆ Related Products



P. 85

P. 81

P. 82

P. 83

P. 109

P. 111

P. 115

P. 124

P. 123

67

MAG Resistance Type Grease Pneumatic Lubricator



MAG-50-0-1-A

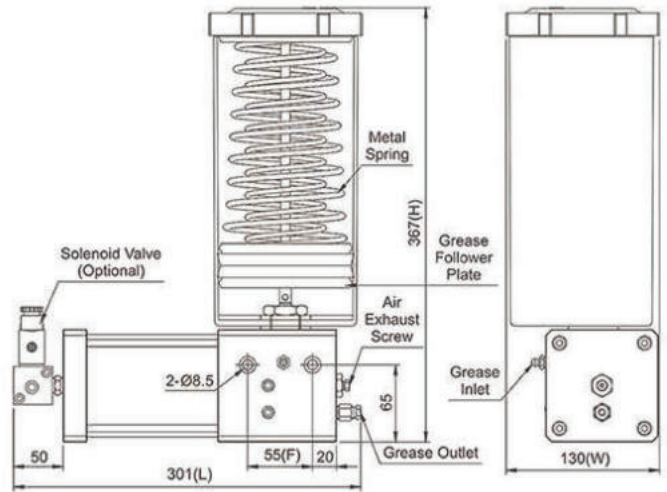

Dimensional Drawing of MAG-50-0-1-A

◆ Features

1. The operation and interval time of MAG are controlled pneumatically.
2. A solenoid valve can be added as a switch for the pneumatic pressure supply to control the ON/OFF switch of MAG upon request.
3. The operation time (ON) should be set up as 25 seconds, and the interval time (OFF) should be set up as 5 seconds to complete one operation cycle.
4. MAG requires 4-8kgf/cm² pneumatic pressure supply to have the corresponding 117-290kgf/cm² operating pressure. It can meet different pressure requirements and applications.
5. Please refill grease from the grease inlet to prevent air and impurities from entering the grease tank.

◆ Technical Data & Dimensional Data

Effective Capacity	Length (mm)	Width (mm)	Height (mm)	Mounting Hole Distance (mm)	Operation Time	Interval Time	Discharge Volume	Grease Inlet	Air Inlet	Discharge Bore	Suitable Viscosity	N.W. (kg)
1500cc	292 309	130	367	55	Over 25 sec.	Over 5 sec.	About 2.5 cc/stroke	Ø8 Ø10	PT1/8 Grease Nipple	Ø4 Ø6 Ø8 Ø10	Grease NLGI 000-2	1.08

◆ Pressure Chart (Reference Value)

Pneumatic Pressure (kgf/cm ²)	4.0	4.5	5.0	5.5	6.0	6.5	7.0	7.5	8.0
Operating Pressure (kgf/cm ²)	117	140	160	181	201	222	242	265	290

◆ Order Code

MAG — 50 — 0 — 1 — 0 — ✕

Effective Capacity	
50	1500cc

Air Inlet	
0	Ø8
1	Ø10

Discharge Bore	
0	Ø4 xPT1/4
1	Ø6 xPT1/4
2	Ø8 xPT1/4
3	Ø10xPT1/4

Solenoid Valve	
0	Without a Solenoid Valve
A	With a Solenoid Valve, 110V
C	With a Solenoid Valve, 220V
K	With a Solenoid Valve, DC24V

Special Request	
G	Add a Pressure Gauge
RC	Add a NC Contact Magnetic Level Switch
RO	Add a NO Contact Magnetic Level Switch

◆ Related Products



KGB / KGBP Pressure-Relief Type Grease Electric Lubricator

PLC



KGB-35-C-5



KGBP-07-C-5 with Grease Cartridge

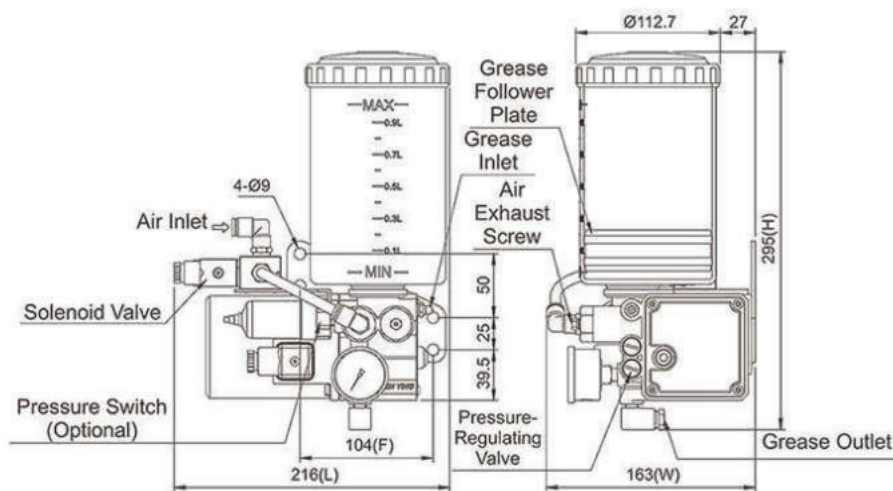

Dimensional Drawing of KGB-35-C-5-PC

◆ Features

1. The operation and interval time of KGB and KGBP are controlled by PLC. KGB and KGBP require 4.5-8kgf/cm² pneumatic pressure supply for the pressure-relief function.
2. KGB and KGBP have to work with CFB volume type grease distributors to deliver the metered quantity of grease to the lubrication points.
3. KGB and KGBP have pressure gauges that enable the user to check the operating pressure easily.
4. KGB and KGBP have feed-grease buttons, which can be used as manual grease feeding for less than 3 minutes to avoid overloading the motor.
5. 1Ø110V and 1Ø220V models have thermal controls that will shut down the motors for about 5 minutes when the motor is overheated.
6. A 60kgf/cm² socket pressure switch can be added to KGB and KGBP on request to detect the operating pressure automatically.
7. A magnetic level switch can be added to KGB and KGBP on request to detect the grease level automatically.
8. For KGB, refill grease from the grease inlet to prevent air and impurities from entering the grease tank.
9. KGBP-07 works with a 700cc disposable grease cartridge. When the grease is empty, replace KGBP-07 with a new grease cartridge. Standard KGBP-07 does not include a grease cartridge but is available upon request.

◆ Dimensional Data (KGB)

Model	Tank Capacity	Length (mm)	Width (mm)	Height (mm)	Mounting Hole Distance (mm)	N.W. (kg)
KGB-35	1000cc	216	163	295	104	4.37
KGB-50	2000cc	224	163	380		5.85

◆ Dimensional Data (KGBP)

Model	Effective Capacity	Length (mm)	Width (mm)	Height (mm)	Mounting Hole Distance (mm)	N.W. (kg)
KGBP-07	700cc Grease Cartridge	220	163	302	104	4.42

KGB / KGBP Pressure-Relief Type Grease Electric Lubricator

PLC

◆ Technical Data

Voltage	AC110V	AC220V	DC24V
Motor Output	60W	80W	60W
Motor Ampere	1.8A	1.0A	1.65A
Solenoid Valve Ampere	0.1 A	0.1 A	0.2A
Hertz	50/60Hz Compatible		--
Max. Discharge Volume	30cc/min		35cc/min
Max. Operating Pressure	100kgf/cm ²		
Discharge Bore	∅6, ∅8, PT1/8		
Suitable Viscosity	KGB: Grease, NLGI 000-0 KGBP-07: Grease, NLGI 000-1		

◆ Wiring Diagram

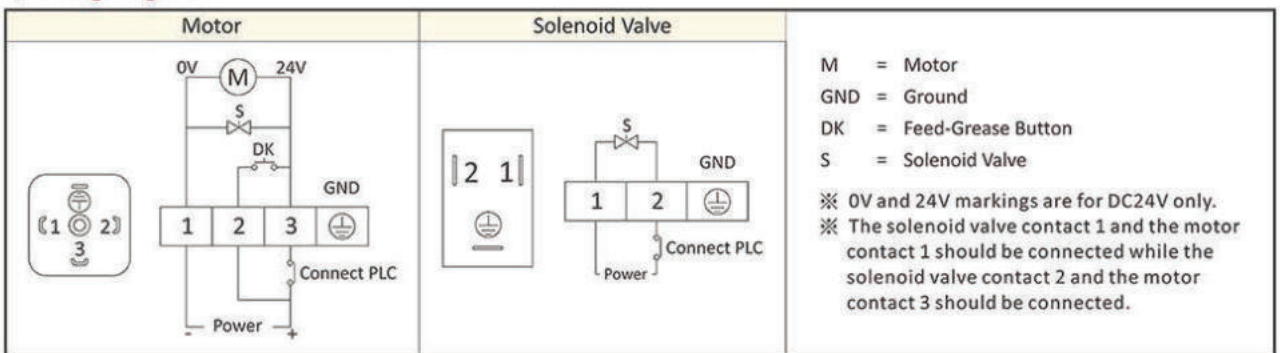

◆ Order Code (KGB)

KGB — 35 — C — 5 — ※

Tank Capacity		Voltage		Discharge Bore		Special Request	
35	1000cc	A	1∅110V	1	∅6	PC	Add a NC Contact Pressure Switch
50	2000cc	C	1∅220V	3	∅6 W/Pressure Gauge	PO	Add a NO Contact Pressure Switch
		K	DC24V	4	∅8	RC	Add a NC Contact Magnetic Level Switch
				5	∅8 W/Pressure Gauge	RO	Add a NO Contact Magnetic Level Switch
				6	PT1/8		
				7	PT1/8 W/Pressure Gauge		

◆ Order Code (KGBP)

KGBP — 07 — C — 3 — ※

Effective Capacity		Voltage		Discharge Bore		Special Request	
07	700cc Grease Cartridge	A	1∅110V	1	∅6	PC	Add a NC Contact Pressure Switch
		C	1∅220V	3	∅6 W/Pressure Gauge	PO	Add a NO Contact Pressure Switch
		K	DC24V	4	∅8	RC	Add a NC Contact Magnetic Level Switch
				5	∅8 W/Pressure Gauge	RO	Add a NO Contact Magnetic Level Switch
				6	PT1/8		
				7	PT1/8 W/Pressure Gauge		

※ Please refer to the 700cc Grease Cartridge catalog if you need to purchase one.

◆ Related Products



KAB / KABP Pressure-Relief Type Grease Electric Lubricator

PLC



KAB-35-K-3-PC-RC

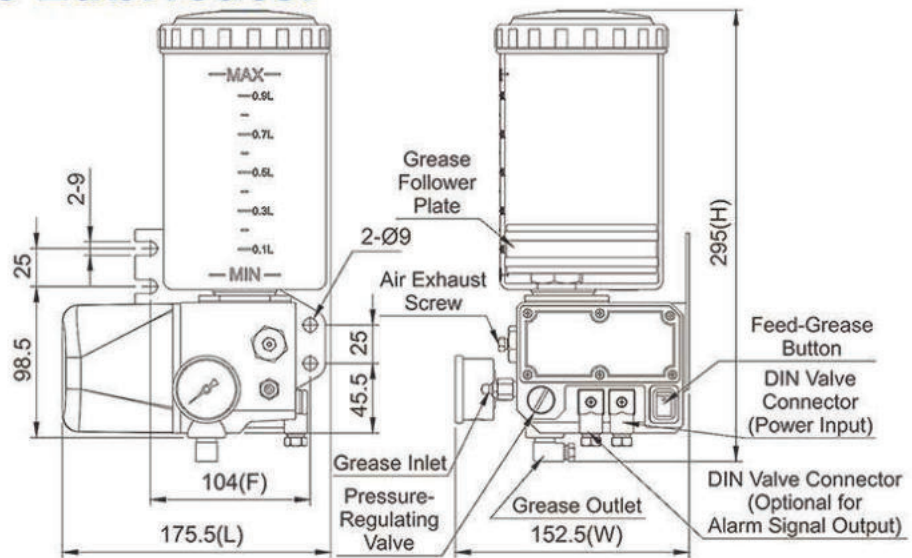

Dimensional Drawing of KAB-35-K-3-PC-RC



KABP-07-K-3-PC-RC

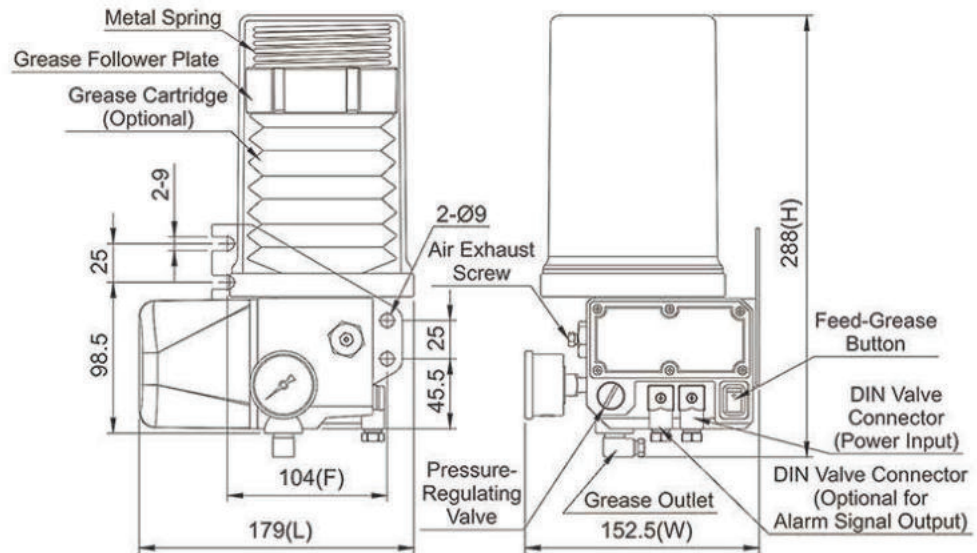

Dimensional Drawing of KABP-07-K-3-PC-RC with Grease Cartridge

◆ Features

1. The operation and interval time of KAB and KABP are controlled by PLC.
2. KAB and KABP have to work with CFB volume type grease distributors to deliver the metered quantity of grease to the lubrication points.
3. KAB and KABP have pressure gauges that enable the users to check the operating pressure easily.
4. KAB and KABP have feed-grease buttons, which can be used as manual grease feeding for less than 3 minutes to avoid overloading the motor.
5. A 60kgf/cm² socket pressure switch can be added to KAB and KABP on request to detect the operating pressure automatically.
6. A magnetic level switch can be added to KAB and KABP on request to detect the grease level automatically.
7. For KAB, please refill grease from the grease inlet to prevent air and impurities from going into the grease tank.
8. KABP-07 works with a 700cc disposable grease cartridge. When the grease is empty, replace KABP-07 with a new grease cartridge. Standard KABP-07 does not include a grease cartridge but is available upon request.

◆ Dimensional Data (KAB)

Model	Tank Capacity	Length (mm)	Width (mm)	Height (mm)	Mounting Hole Distance (mm)	N.W. (kg)
KAB-40	800cc	172.0	152.5	338	104	2.32
KAB-35	1000cc	175.5	152.5	295		2.41
KAB-50	2000cc	182.5	152.5	379		2.74

◆ Dimensional Data (KABP)

Model	Effective Capacity	Length (mm)	Width (mm)	Height (mm)	Mounting Hole Distance (mm)	N.W. (kg)
KABP-07	700cc Grease Cartridge	179.0	152.5	288	104	2.49

KAB / KABP Pressure-Relief Type Grease Electric Lubricator

PLC

◆ Technical Data

Motor Power	Voltage	Ampere	Max. Discharge Volume	Max. Operating Pressure	Discharge Bore	Suitable Viscosity
35±3W	DC24V	3.0A	10cc/min	100kgf/cm ²	∅6, ∅8	Grease, NLGI 000-0

◆ Wiring Diagram

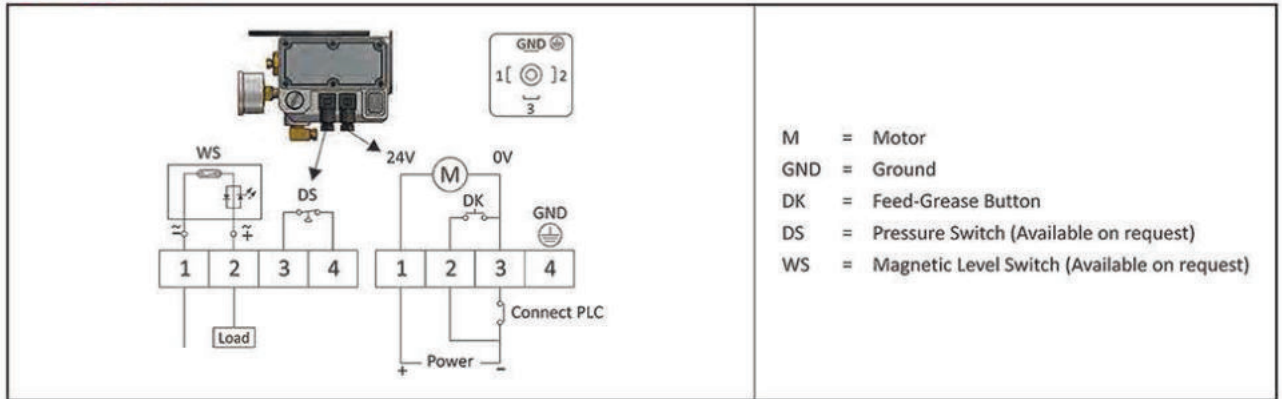

◆ Order Code (KAB)

KAB — 35 — K — 3 — ※

Tank Capacity		Voltage		Discharge Bore		Special Request	
40	800cc	K	DC24V	1	∅6	PC	Add a NC Contact Pressure Switch
35	1000cc			3	∅6 W/Pressure Gauge	PO	Add a NO Contact Pressure Switch
50	2000cc			4	∅8	RC	Add a NC Contact Magnetic Level Switch
				5	∅8 W/Pressure Gauge	RO	Add a NO Contact Magnetic Level Switch

◆ Order Code (KABP)

KABP — 07 — K — 3 — ※

Effective Capacity		Voltage		Discharge Bore		Special Request	
07	700cc Grease Cartridge	K	DC24V	1	∅6	PC	Add a NC Contact Pressure Switch
				3	∅6 W/Pressure Gauge	PO	Add a NO Contact Pressure Switch
				4	∅8	RC	Add a NC Contact Magnetic Level Switch
				5	∅8 W/Pressure Gauge	RO	Add a NO Contact Magnetic Level Switch

※ Please refer to the 700cc Grease Cartridge catalog if you need to purchase one.

◆ Related Products



KGVB Pressure-Relief Type PLC Fluid Grease Electric Lubricator

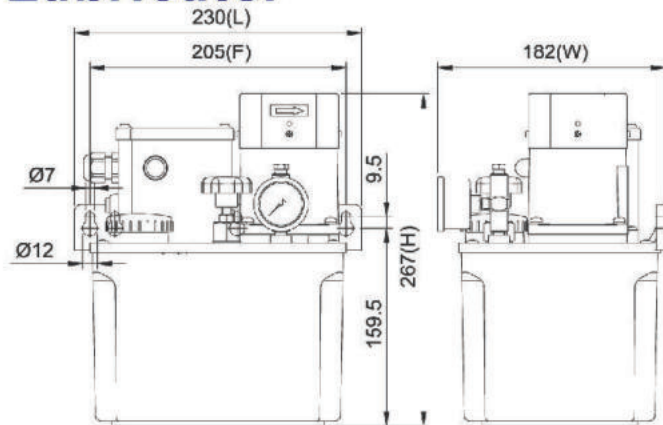

◆ Features

KGVB-03-C-40-3

Dimensional Drawing of KGVB-03-C-40-3

1. The operation and interval time of KGVB are controlled by PLC.
2. KGVB has to work with CFB volume type grease distributors to deliver the metered quantity of grease to the lubrication points.
3. KGVB has a pressure-regulating valve that enables the user to adjust the operating pressure. KGVB also has a feed-grease button, which can be used as manual grease feeding for less than 3 minutes to avoid overloading the motor.
4. A 20kgf/cm² socket pressure switch can be added to KGVB on request to detect the operating pressure automatically.
5. A capacitive level switch can be added to KGVB on request to detect the grease level automatically.
6. The gear pump of KGVB is made of special aluminum alloy and assembled with a 40W induction motor to provide stable output pressure, low operating noise, and long service life.
7. The induction motor has a fan that can reduce the temperature and prolong the service life of KGVB.

◆ Order Code

KGVB — 03 — C — 40 — 3 — ※

Tank Capacity (Material)	
03	3L (Resin)
04	4L (Resin)
05	4L (Alum.)
08	8L (Iron)

Voltage	
A	1Ø110V
C	1Ø220V
D	3Ø220/380V

Motor Power	
40	40W

Discharge Bore	
1	Ø6
3	Ø6 W/Pressure Gauge

Special Request	
PC	Add a NC Contact Pressure Switch
PO	Add a NO Contact Pressure Switch
KO	Add a PNP, NO Contact Capacitive Level Switch

◆ Dimensional Data

Tank Capacity	Tank Material	Length (mm)	Width (mm)	Height (mm)	Mounting Hole Distance (mm)	N.W. (kg)
3L	Resin	230	182	267	205	5.29
4L	Resin	288	162	278	250	5.89
4L	Alum.	297	170	276	95x280	6.84
8L	Iron	355	201	299	95x338	9.54

◆ Technical Data

Voltage	1Ø110V	1Ø220V	3Ø220/380V
Ampere	0.75A	0.50A	0.40A
Motor Power	40W		
Hertz	50/60Hz Compatible		
Max. Discharge Volume	170cc/min		
Max. Operating Pressure	40kgf/cm ²		
Discharge Bore	Ø6		
Suitable Viscosity	NLGI 000, 00 (NLGI 00 is suitable for the model with 3L resin tank only.)		

◆ Wiring Diagram

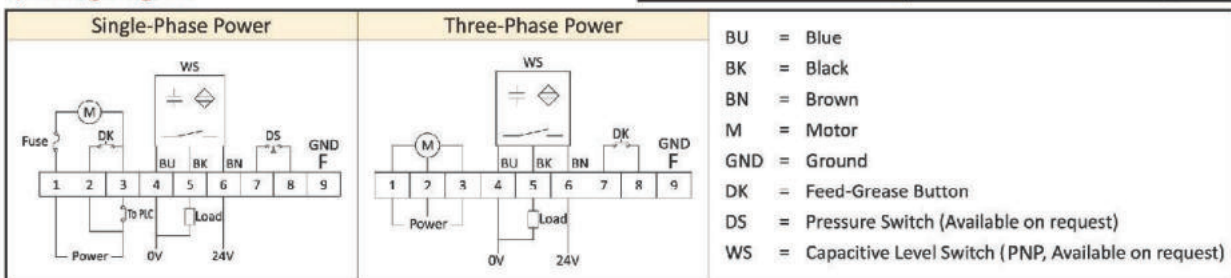

※ A standard dual-voltage motor is connected for low voltage. Please specify if you need it to be connected to high voltage when placing an order.

◆ Related Products



P. 98

P. 109

P. 111

P. 113

P. 112

P. 124

P. 123

P. 125

P. 129

KGNVB Pressure-Relief Type Timer Fluid Grease Electric Lubricator



KGNVB-03-C-40-3

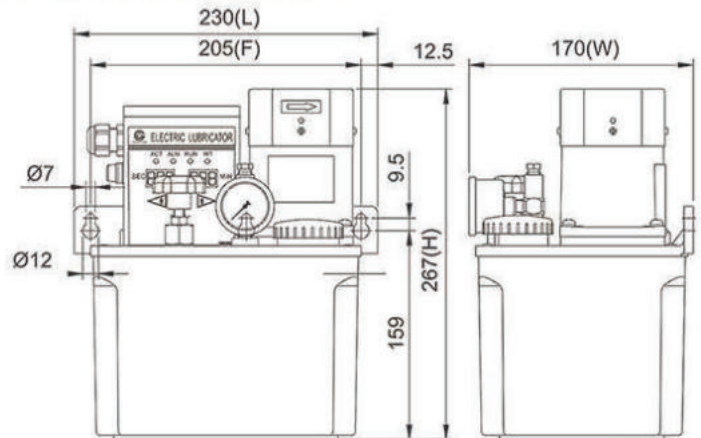

Dimensional Drawing of KGNVB-03-C-40-3

◆ Features

1. KGNVB has a timer that controls its operation and interval time.
2. KGNVB has to work with CFB volume type grease distributors to deliver the metered quantity of grease to the lubrication points.
3. There are four indicators on the control box, operation (ACT), alarm (ALM), immediate lubrication (RUN), and interval (INT).
4. KGNVB has a pressure-regulating valve that enables the user to adjust the operating pressure. KGNVB also has a feed-grease button (F button), which can be used as manual grease feeding for less than 3 minutes to avoid overloading the motor.
5. 20kgf/cm² socket pressure switch can be added to KGNVB on request to detect the operating pressure automatically.
6. The gear pump of KGNVB is made of special aluminum alloy and assembled with a 40W induction motor to provide stable output pressure, low operating noise, and long service life.
7. The induction motor has a fan that can reduce the temperature and prolong the service life of KGNVB.

◆ Order Code

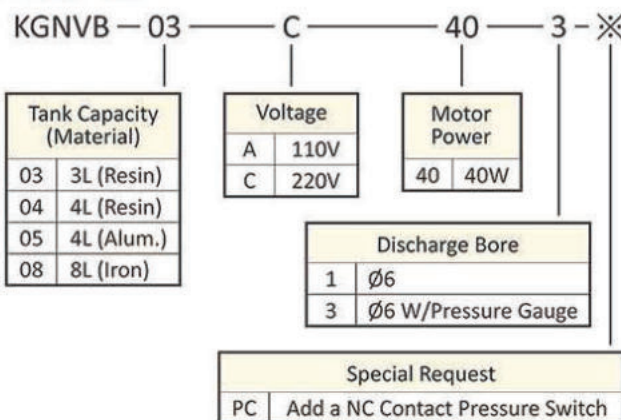

◆ Dimensional Data

Tank Capacity	Tank Material	Length (mm)	Width (mm)	Height (mm)	Mounting Hole Distance (mm)	N.W. (kg)
3L	Resin	230	170	267	205	5.59
4L	Resin	277	162	278	250	6.09
4L	Alum.	297	170	276	95x280	6.94
8L	Iron	355	201	299	95x338	10.09

◆ Technical Data

Operation Time	1-999 sec.	
Interval Time	1-999 min.	
Voltage	110V	220V
Ampere	0.75A	0.50A
Motor Power	40W	
Hertz	50/60Hz Compatible	
Max. Discharge Volume	170cc/min	
Max. Operating Pressure	40kgf/cm ²	
Discharge Bore	∅6	
Suitable Viscosity	NLGI 000, 00 (NLGI 00 is suitable for the model with 3L resin tank only.)	

◆ Wiring Diagram

Abnormal Output			Ground	Power
NO(A)	NC(B)	COM	GND(P.E)	POWER
⊕	⊕	⊕	⊕	⊕ ⊕

◆ Related Products



P. 98

P. 109

P. 111

P. 113

P. 112

P. 124

P. 123

P. 125

P. 129

KGNB / KGNBP Pressure-Relief Type Grease Electric Lubricator Timer



KGNB-35-2-C-5-PC



KGNBP-07-2-C-5



KGNBP-07-2-C-5 with Grease Cartridge

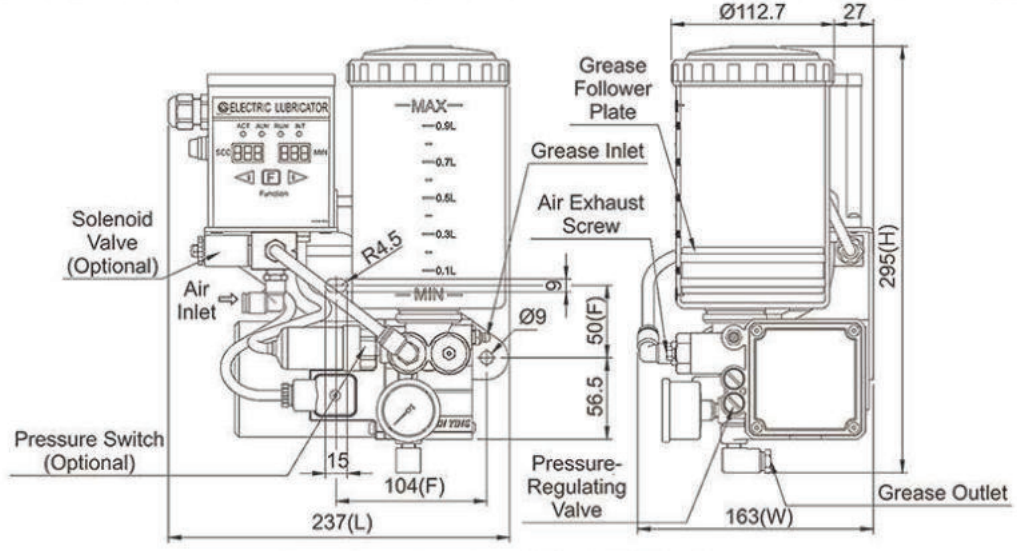

Dimensional Drawing of KGNB-35-2-C-5-PC

◆ Features

1. The operation and interval time of KGNB and KGNBP are controlled by PLC. KGNB and KGNBP require a 4.5-8kgf/cm² pneumatic pressure supply for the pressure-relief function.
2. KGNB and KGNBP have to work with CFB volume type grease distributors to deliver the metered quantity of grease to the lubrication points.
3. There are four indicators on the control box, operation (ACT), alarm (ALM), immediate lubrication (RUN), and interval (INT).
4. KGNB and KGNBP have pressure gauges that enable the users to check the operating pressure easily.
5. KGNB and KGNBP have feed-grease buttons (F button), which can be used as manual grease feeding for less than 3 minutes to avoid overloading the motor.
6. KGNB and KGNBP have thermal controls that will shut down the motor for about 5 minutes when the motor is overheated.
7. A 60kgf/cm² socket pressure switch can be added to KGNB and KGNBP on request to detect the operating pressure automatically.
8. A magnetic level switch can be added to KGNB and KGNBP on request to detect the grease level automatically.
9. The lubricator, which adds a pressure switch or a magnetic level switch, has abnormal pressure or low grease level; the built-in buzzer of the control box will send an alarm sound.
10. For KGNB, refill grease from the grease inlet to prevent air and impurities from entering the grease tank.
11. KGNBP-07 works with a 700cc disposable grease cartridge. When the grease is empty, replace KGNBP-07 with a new grease cartridge. Standard KGNBP-07 does not include a grease cartridge but is available upon request.

◆ Dimensional Data (KGNB)

Model	Tank Capacity	Length (mm)	Width (mm)	Height (mm)	Mounting Hole Distance (mm)	N.W. (kg)
KGNB-35	1000cc	237	163	295	104x50	4.95
KGNB-50	2000cc	245	163	380		5.41

◆ Dimensional Data (KGNBP)

Model	Effective Capacity	Length (mm)	Width (mm)	Height (mm)	Mounting Hole Distance (mm)	N.W. (kg)
KGNBP-07	700cc Grease Cartridge	241	163	302	104x50	5.00

KGNB / KGNBP Pressure-Relief Type Grease Electric Lubricator

KGNB / KGNBP Pressure-Relief Type Grease Electric Lubricator

Timer

◆ Technical Data

Operation Time	1-999 sec.		
Interval Time	1-999 sec., 1-999 min.		
Voltage	110V	220V	
Motor Output	60W	80W	
Ampere	1.8A	1.0A	
Hertz	50/60Hz Compatible		
Max. Discharge Volume	30cc/min		
Max. Operating Pressure	100kgf/cm ²		
Discharge Bore	∅6, ∅8, PT1/8		
Suitable Viscosity	KGNB: Grease, NLGI 000-0 KGNBP-07: Grease, NLGI 000-1		

◆ Wiring Diagram

Abnormal Output			Ground	Power	
NO(A)	NC(B)	COM	GND(P.E)	POWER	
⊕	⊕	⊕	⊕	⊕	⊕

◆ Order Code (KGNB)

KGNB - 35 - 2 - C - 5 - ※

Tank Capacity	Voltage	Discharge Bore	Special Request
35 1000cc 50 2000cc	A 110V C 220V	1 ∅6 3 ∅6 W/Pressure Gauge 4 ∅8 5 ∅8 W/Pressure Gauge 6 PT1/8 7 PT1/8 W/Pressure Gauge	PC Add a NC Contact Pressure Switch RC Add a NC Contact Magnetic Level Switch

Time Setting
1 sec x sec 2 sec x min

◆ Order Code (KGNBP)

KGNBP - 07 - 2 - C - 5 - ※

Effective Capacity	Voltage	Discharge Bore	Special Request
07 700cc Grease Cartridge	A 110V C 220V	1 ∅6 3 ∅6 W/Pressure Gauge 4 ∅8 5 ∅8 W/Pressure Gauge 6 PT1/8 7 PT1/8 W/Pressure Gauge	PC Add a NC Contact Pressure Switch RC Add a NC Contact Magnetic Level Switch

Time Setting
1 sec x sec 2 sec x min

※ Please refer to the 700cc Grease Cartridge catalog if you need to purchase one.

◆ Related Products



P. 98

P. 109

P. 111

P. 113

P. 80

P. 124

P. 123

P. 125

P. 129

POM-A / POM-AP Minimum Quantity Grease Pneumatic Lubricator



POM-A-35-1-K-0

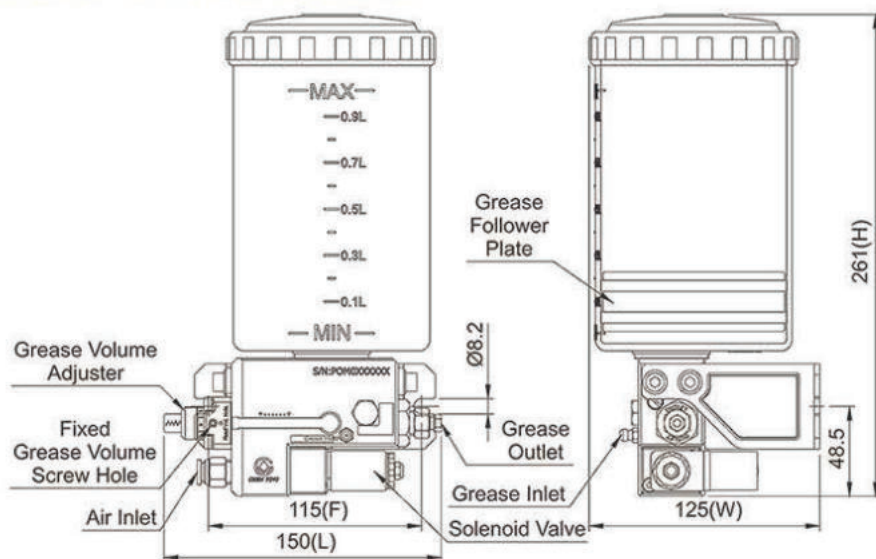

Dimensional Drawing of POM-A-35-1-K-0



POM-AP-07-1-K-0
with Grease Cartridge

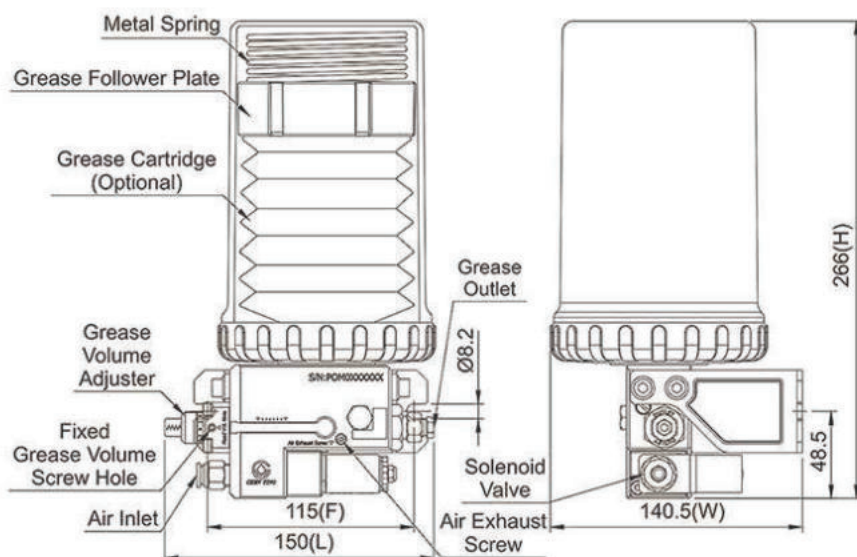

Dimensional Drawing of POM-AP-07-1-K-0 with Grease Cartridge

◆ Features

1. The discharge volume of POM-A and POM-AP is precise and can be adjusted from 0.01cc to 0.08cc per stroke.
2. POM-A and POM-AP can be actuated either by a frequency generator or a solenoid valve.
 - Pneumatic pressure supply drives the frequency generator, and the user can adjust each stroke frequency upon the demand. The service life is ten million cycles.
 - The input voltage powers the solenoid valve, and the PLC can precisely control its stroke frequency. The solenoid valve works as the ON/OFF switch of the pneumatic pressure supply. The service life is two million cycles.
3. POM-A and POM-AP require 4-8kgf/cm² pneumatic pressure supply to operate.
4. The standard POM-A and POM-AP have one outlet, which can be increased to two on request. Do not plug any outlet of POM-A and POM-AP.
5. POM-A and POM-AP have grease volume adjusters for adjusting the discharge volume per stroke. It is fixed by the grease volume screw to prevent its setting from being changed easily.
6. Each outlet of POM-A can add a reed switch for monitoring every stroke.
7. A magnetic level switch can be added to POM-A and POM-AP on request to detect the grease level automatically.
8. An OT spray gun with the Ø4 inlet bore can work with either POM-A or POM-MP to have the grease mist effect.
9. Please refill grease from the grease inlet to prevent air and impurities from entering the grease tank.
10. POM-AP-07 works with a 700cc disposable grease cartridge. When the grease is empty, replace POM-AP-07 with a new grease cartridge. Standard POM-AP-07 does not include a grease cartridge but is available upon request.

POM-A / POM-AP Minimum Quantity Grease Pneumatic Lubricator

◆ Dimensional Data (POM-A)

Model	Effective Capacity	Mounting Hole Distance (mm)	Length (mm)	Width (mm)	Height (mm)	Outlet Number	N.W. (kg)
POM-A-35	1000cc	115	150	125.0	261.0	1	1.67
					289.5	2	2.08
POM-A-50	2000cc	115	154	135.0	345.5	1	2.02
					374.0	2	2.43

◆ Dimensional Data (POM-AP)

Model	Effective Capacity	Mounting Hole Distance (mm)	Length (mm)	Width (mm)	Height (mm)	Outlet Number	N.W. (kg)
POM-AP-07	700cc Grease Cartridge	115	150	140.5	266.0	1	1.82
					294.5	2	2.23
POM-AP-40	550cc	115	150	125.0	304.5	1	1.94
					330.0	2	2.35
POM-AP-50	1500cc	115	154	135.0	345.5	1	3.02
					374.0	2	3.43

◆ Technical Data

Method of Actuation	Solenoid Valve			Frequency Generator
Voltage	AC110V	AC220V	DC24V	--
Ampere	0.1A	0.1A	0.2A	--
Pneumatic Pressure	4-8kgf/cm ²			
Discharge Volume	0.01cc-0.08cc/stroke (Adjustable)			
Air Inlet Bore	∅8			
Discharge Bore	∅4			
Suitable Viscosity	POM-A: Grease, NLGI 000-0 POM-AP-07: Grease, NLGI 000-0 POM-AP-40, POM-AP-50: Grease, NLGI 1, 2			

◆ Order Code (POM-A)

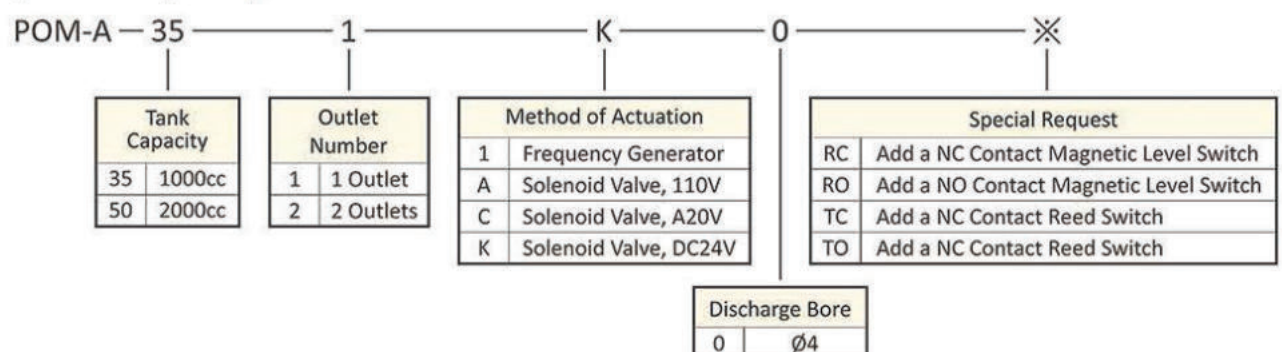

POM-A / POM-AP Minimum Quantity Grease Pneumatic Lubricator

◆ Order Code (POM-AP)

POM-AP - 07 - 1 - K - 0 - ※

Effective Capacity		Outlet Number		Method of Actuation		Special Request	
40	550cc	1	1 Outlet	1	Frequency Generator	RC	Add a NC Contact Magnetic Level Switch
50	1500cc	2	2 Outlets	A	Solenoid Valve, 110V	RO	Add a NO Contact Magnetic Level Switch
	700cc			C	Solenoid Valve, A20V	TC	Add a NC Contact Reed Switch
07	Grease Cartridge			K	Solenoid Valve, DC24V	TO	Add a NC Contact Reed Switch

Discharge Bore	
0	Ø4

◆ Minimum Quantity Grease Lubrication System Installation Schematic Diagram

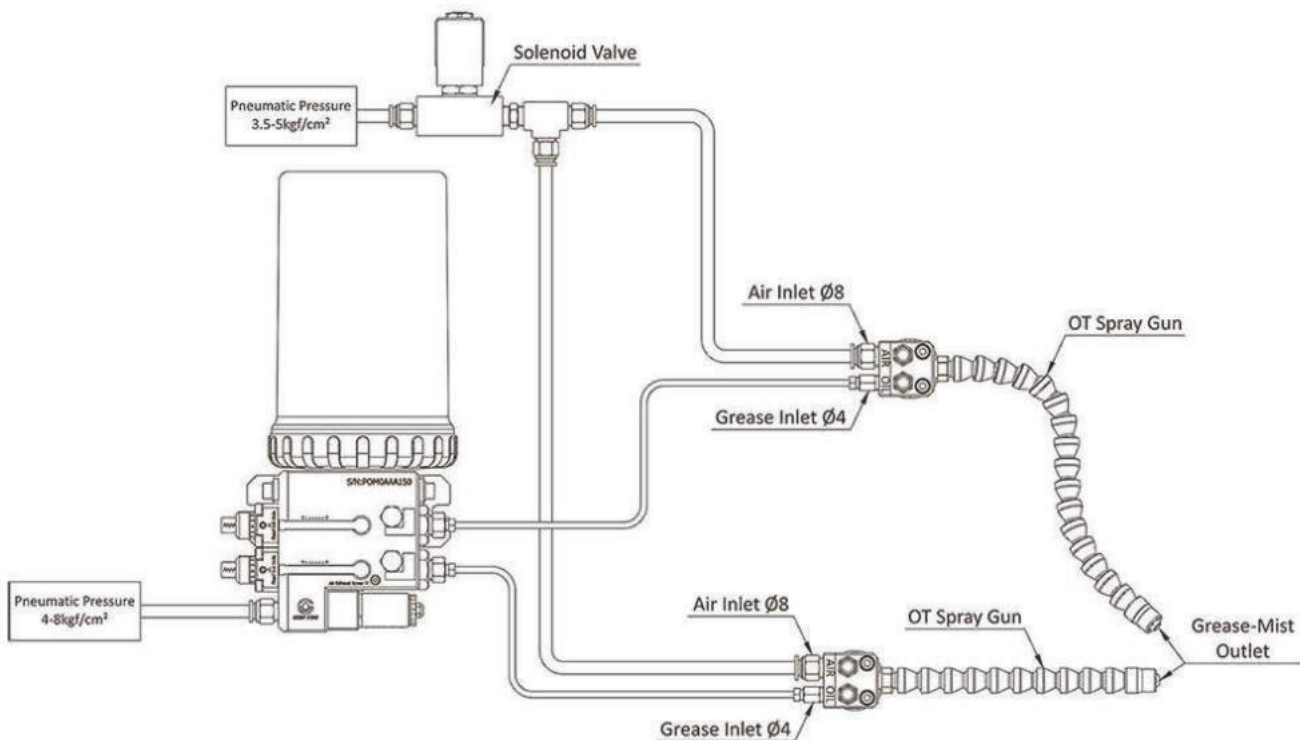

◆ Related Products



700cc Grease Cartridge



◆ Order Code

Order Code	Grease Type	Grease Viscosity	Minimum Order Quantity Requirement
I01D0021	Mobil EP000	NLGI 000	--
I01D0012	Mobil EP0	NLGI 0	--
I01D0013	Mobil EP1	NLGI 1	100

◆ Features

1. 700cc grease cartridge is suitable for KACP-07, KABP-07, KGCP-07, KGNP-07, KGBP-07, KGNBP-07, and POM-AP-07 types grease lubricators.
2. Standard 700cc grease cartridge is filled with Mobil grease. Please specify when you place an order if you require a different brand.

◆ Notice

1. Please discard the empty used grease cartridge and replace a new one. Do not refill grease into the used grease cartridge.
2. Please hold the grease tank tightly to prevent it from popping out by the spring force while disassembling.
3. Before replacing a new grease cartridge, lightly squeeze out a little grease in the grease cartridge to prevent air from entering the lubricator.

◆ Instruction of Replacing 700cc Grease Cartridge

1		<p>Hold the grease tank tightly and turn it anticlockwise to disassemble it from the grease tank holder.</p>	5		<p>Assemble the new grease cartridge to the grease tank holder by turning it clockwise.</p>
2		<p>Take the grease tank out and put it aside.</p>	6		<p>Assemble the grease tank back to the grease tank holder.</p>
3		<p>Rotate the used grease cartridge anticlockwise to remove it from the grease tank holder and dispose of it properly.</p>	7		<p>Rotate the grease tank clockwise to assemble it with the grease tank holder to complete the replacement of the grease cartridge.</p>
4		<p>Before replacing a new grease cartridge, lightly squeeze out a little grease in the grease cartridge to prevent air from entering the lubricator.</p>			

A Type Distributor



A-6-6-4

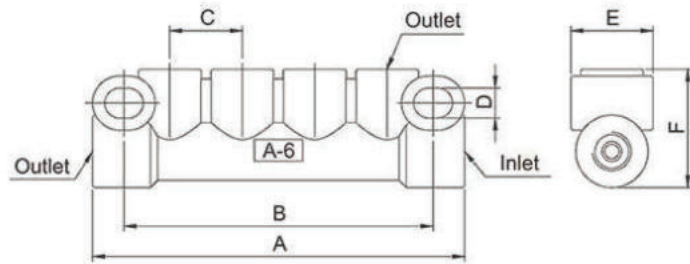

Dimensional Drawing of A-6-6-4

Order Code

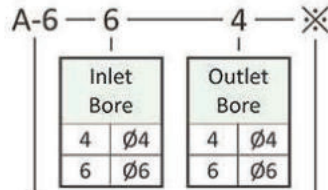

Model
A-4
A-5
A-6
A-7
A-8
A-9
A-10
A-12
A-700
A-8000
A-900
A-1000
DB-12

※ ∅6 outlet bore is only available for A-4, A-5, and A-6.

Special Request	
S	Add Compression Bushing and Sleeve to Inlet and Outlets

Dimensional Data

Standard Models													
Model	Outlet Num.	Inlet Bore	Outlet Bore	A (mm)	B (mm)	C (mm)	D (mm)	E (mm)	F (mm)	N.W. (g)		Suitable Lubricant	
										∅4x∅4	∅6x∅4		
A-4	3	∅4 (M8xP1.0)	∅4 (M8xP1.0)	47	34	15	∅6.2	17	24.5	70	68	Oil & Grease	
A-5	4		or	62	50	15	∅6.2	17	24.5	86	83		
A-6	5		∅6 (M10xP1.0)	82	68	15	∅6.2	17	24.5	110	108		
A-7	6	or ∅6 (M10xP1.0)	∅4 (M8xP1.0)	92	78	15	∅6.2	17	24.5	125	120		
A-8	7			107	93	15	∅6.2	17	24.5	131	127		
A-9	8			122	108	15	∅6.2	17	24.5	158	157		
A-10	9			137	123	15	∅6.6	18	25.0	175	170		
A-12	11			167	152	15	∅6.6	18	25.0	201	200		
Non-Standard Models													
Model	Outlet Num.	Inlet Bore	Outlet Bore	A (mm)	B (mm)	C (mm)	D (mm)	E (mm)	F (mm)	N.W. (g)			Suitable Lubricant
										∅4x∅4	∅6x∅4		
A-700	6	∅4	∅4 (M8xP1.0)	98	84	16	∅6.2	17	23.5	124	122	Oil & Grease	
A-8000	7	(M8xP1.0)		115	100	15	∅6.6	19	24.0	136	134		
A-900	8	or ∅6		134	115	16	∅6.8	18	26.0	160	154		
A-1000	9	∅6		146	132	16	∅6.5	20	25.0	176	173		
DB-12	11	(M10xP1.0)		176	164	16	∅6.5	20	24.5	212	210		

※ Standard Type: inlet bore ∅6, and outlet bore ∅4

※ Both inlet and outlet bore PT1/8 are available for A-4, A-5, and A-6.

AE Type Distributor



AE-8-6-4

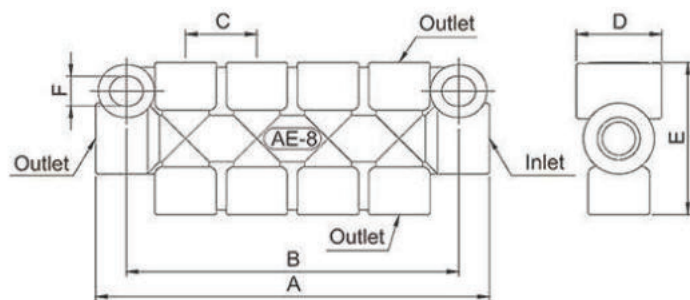

Dimensional Drawing of AE-8-6-4

Order Code

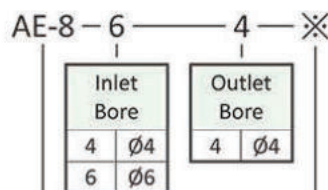

Model
AE-4
AE-6
AE-8
AE-10
AE-12

Special Request	
S	Add Compression Bushing and Sleeve to Inlet and Outlets

Dimensional Data

Standard Models												
Model	Outlet Num.	Inlet Bore	Outlet Bore	A (mm)	B (mm)	C (mm)	D (mm)	E (mm)	F (mm)	N.W. (g)		Suitable Lubricant
										∅4x∅4	∅6x∅4	
AE-4	5	∅4 (M8xP1.0)	∅4 (M8xP1.0)	48	35	16	18	32.1	∅7.0	73	71	Oil & Grease
AE-6	7			65	51	15	20	33.0	∅7.5	103	101	
AE-8	9	or ∅6		83	70	15	18	32.0	∅6.2	114	113	
AE-10	11	∅6		97	83	15	18	32.0	∅6.2	134	133	
AE-12	13	(M10xP1.0)		112	99	15	18	32.0	∅6.2	157	154	

※ Standard Type: inlet bore ∅6, and outlet bore ∅4

B Type Adjustable Distributor



B-5-6-4

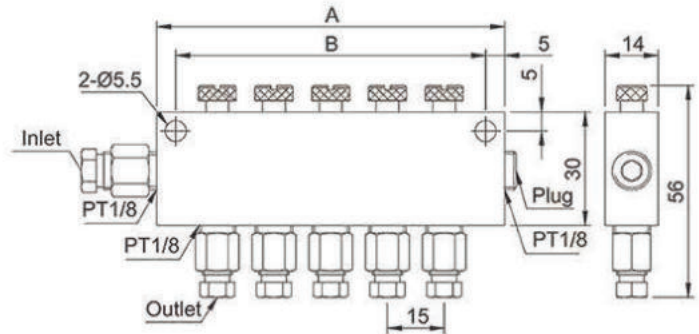

Dimensional Drawing of B-5-6-4

◆ Order Code

B-5	6	4
Model	Inlet Bore	Outlet Bore
B-2	4 $\varnothing 4$	4 $\varnothing 4$
B-3	6 $\varnothing 6$	6 $\varnothing 6$
B-4		
B-5		
B-6		
B-7		
B-8		
B-9		
B-10		
B-11		
B-12		

◆ Dimensional Data

Model	Outlet Num.	Inlet Bore	Outlet Bore	A (mm)	B (mm)	N.W. (g)		Suitable Lubricant
						$\varnothing 4 \times \varnothing 4$	$\varnothing 6 \times \varnothing 4$	
B-2	2	$\varnothing 4$ (M8xP1.0) or $\varnothing 6$ (M10xP1.0)	$\varnothing 4$ (M8xP1.0) or $\varnothing 6$ (M10xP1.0)	47	37	86	88	Oil & Grease
B-3	3			62	52	115	117	
B-4	4			77	67	144	147	
B-5	5			92	82	173	176	
B-6	6			107	97	203	204	
B-7	7			122	112	230	232	
B-8	8			137	127	260	261	
B-9	9			152	142	289	290	
B-10	10			167	157	316	318	
B-11	11			182	172	346	348	
B-12	12			197	187	373	375	

※ Standard Type: inlet bore $\varnothing 6$, and outlet bore $\varnothing 4$

CB Type Anti-Vibration Distributor with Nut



CB-5-6-4

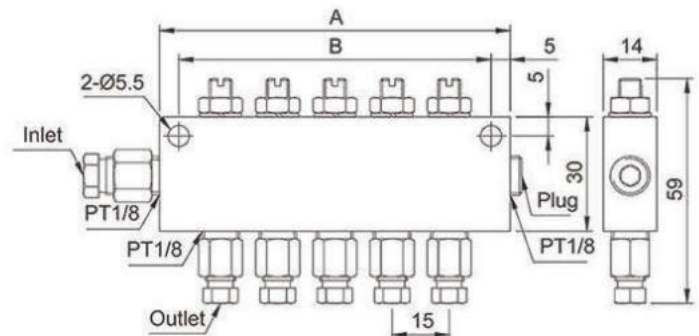

Dimensional Drawing of CB-5-6-4

◆ Order Code

CB-5	6	4
Model	Inlet Bore	Outlet Bore
CB-2	4 $\varnothing 4$	4 $\varnothing 4$
CB-3	6 $\varnothing 6$	6 $\varnothing 6$
CB-4		
CB-5		
CB-6		
CB-7		
CB-8		
CB-9		
CB-10		
CB-11		
CB-12		

◆ Dimensional Data

Model	Outlet Num.	Inlet Bore	Outlet Bore	A (mm)	B (mm)	N.W. (g)		Suitable Lubricant
						$\varnothing 4 \times \varnothing 4$	$\varnothing 6 \times \varnothing 4$	
CB-2	2	$\varnothing 4$ (M8xP1.0) or $\varnothing 6$ (M10xP1.0)	$\varnothing 4$ (M8xP1.0) or $\varnothing 6$ (M10xP1.0)	47	37	92	94	Oil & Grease
CB-3	3			62	52	122	124	
CB-4	4			77	67	153	155	
CB-5	5			92	82	184	186	
CB-6	6			107	97	215	217	
CB-7	7			122	112	248	250	
CB-8	8			137	127	280	282	
CB-9	9			152	142	312	314	
CB-10	10			167	157	339	341	
CB-11	11			182	172	370	372	
CB-12	12			197	187	400	402	

※ Standard Type: inlet bore $\varnothing 6$, and outlet bore $\varnothing 4$

AB Type Adjustable Distributor



AB-4-8-6

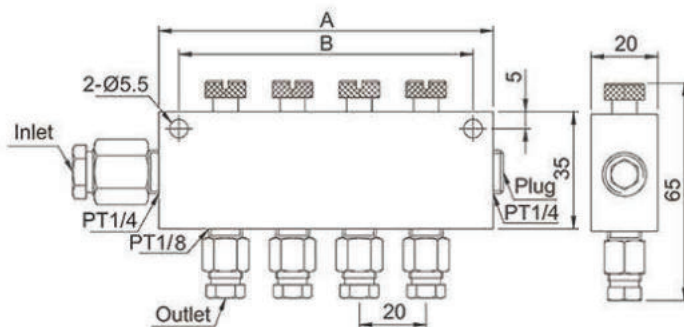

Dimensional Drawing of AB-4-8-6

Order Code

AB-4	8	6
Model	Inlet Bore	Outlet Bore
AB-2	6 Ø6	6 Ø6
AB-3	6 Ø6	6 Ø6
AB-4	8 Ø8	8 Ø8
AB-5		
AB-6		
AB-7		
AB-8		

Dimensional Data

Model	Outlet Num.	Inlet Bore	Outlet Bore	A (mm)	B (mm)	N.W. (g)		Suitable Lubricant
						Ø6xØ6	Ø8xØ6	
AB-2	2	Ø6 (M10xP1.0) or Ø8 (M14xP1.5)	Ø6 (M10xP1.0) or Ø8 (M14xP1.5)	60	50	166	186	Oil & Grease
AB-3	3			80	70	221	240	
AB-4	4			100	90	277	295	
AB-5	5			120	108	333	352	
AB-6	6			140	127	388	407	
AB-7	7			160	148	443	462	
AB-8	8			180	168	498	514	

※ Standard Type: inlet bore Ø8, and outlet bore Ø6

AE Type Grease Nipple Distributor with Parallel Outlets



AE-81

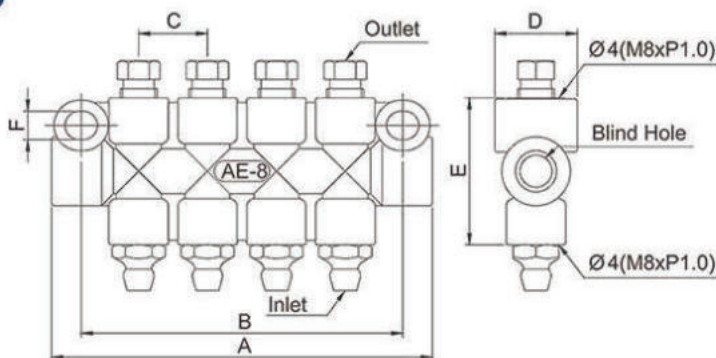

Dimensional Drawing of AE-81

Dimensional Data

Model	Outlet Num.	Inlet Bore	Outlet Bore	A (mm)	B (mm)	C (mm)	D (mm)	E (mm)	F (mm)	N.W. (g)	Suitable Lubricant
AE-41	2	Grease Nipple	Ø4 (M8xP1.0)	48	35	16	18	32.1	Ø7.0	91	Grease
AE-61	3			65	51	15	20	33.0	Ø7.5	130	
AE-81	4			83	70	15	18	32.0	Ø6.2	149	
AE-101	5			97	83	15	18	32.0	Ø6.2	178	
AE-121	6			112	99	15	18	32.0	Ø6.2	208	

BB Type Grease Nipple Distributor with Parallel Outlets

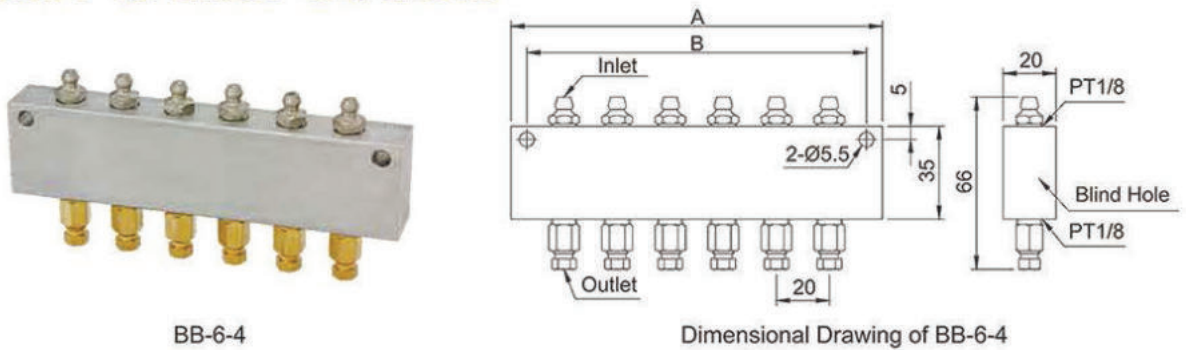

BB-6-4

Dimensional Drawing of BB-6-4

◆ Order Code

BB-6	4
Model	Outlet Bore
BB-2	
BB-3	4 Ø4
BB-4	6 Ø6
BB-5	
BB-6	
BB-7	
BB-8	
BB-10	

◆ Dimensional Data

Model	Outlet Num.	Inlet Bore	Outlet Bore	A (mm)	B (mm)	N.W. (g)		Suitable Lubricant
						Grease Nipple x Ø4	Grease Nipple x Ø6	
BB-2	2	Grease Nipple	Ø4 (M8xP1.0) or Ø6 (M10xP1.0)	60	50	131	135	Grease
BB-3	3			80	70	180	185	
BB-4	4			100	90	228	235	
BB-5	5			120	108	277	286	
BB-6	6			140	127	325	336	
BB-7	7			160	148	373	386	
BB-8	8			180	168	421	436	
BB-10	10			220	208	518	537	

BS Type Transparent Adjustable Distributor

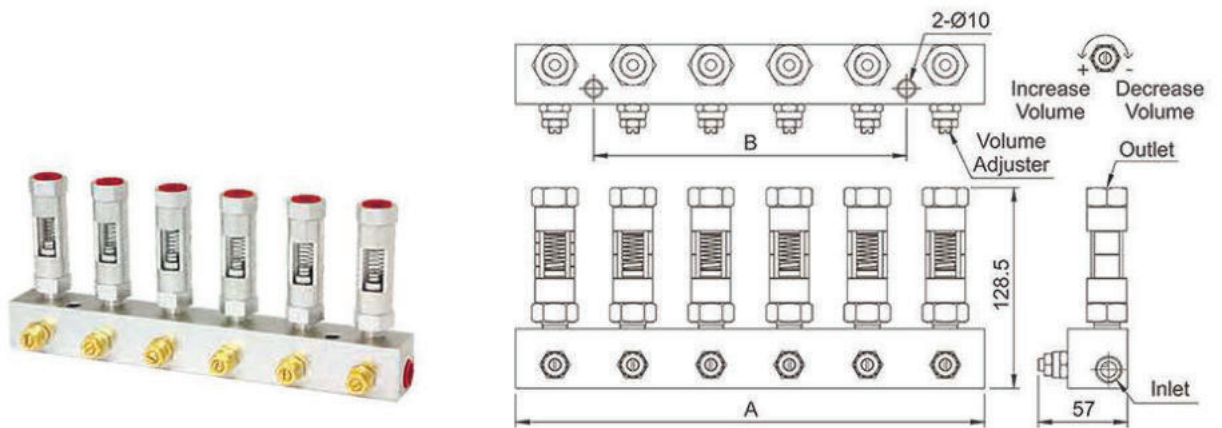

BS-6

Dimensional Drawing of BS-6

◆ Dimensional Data

Model	Outlet Num.	Volume Control Base	Inlet Bore	Outlet Bore	A (mm)	B (mm)	Discharge Volume	Operating Pressure Range	Max. Temp. Tolerance	Suitable Viscosity	N.W. (g)
BS-A	1	X	Inner Thread PT1/4	Inner Thread PT1/4	-	-	1-2L/min (Non-Adjustable)	8-30 kgf/cm ²	80°C	Oil 32-220 cSt@40°C	82.6
BS-B	1		Inner Thread PT3/8	Inner Thread PT3/8							78.6
BS-C	1		Outer Thread PT3/8	Inner Thread PT3/8							88.8
BS-1	1	O	Inner Thread PT3/8	Inner Thread PT3/8	70	50	1-2L/min (Adjustable)	8-30 kgf/cm ²	80°C	Oil 32-220 cSt@40°C	340.0
BS-2	2				120	100					628.0
BS-3	3				150	50					862.0
BS-4	4				200	100					1188.0
BS-5	5				250	149					1490.0
BS-6	6				300	200					1790.0

CV Type Progressive Feeder



CV-8-6-4-1

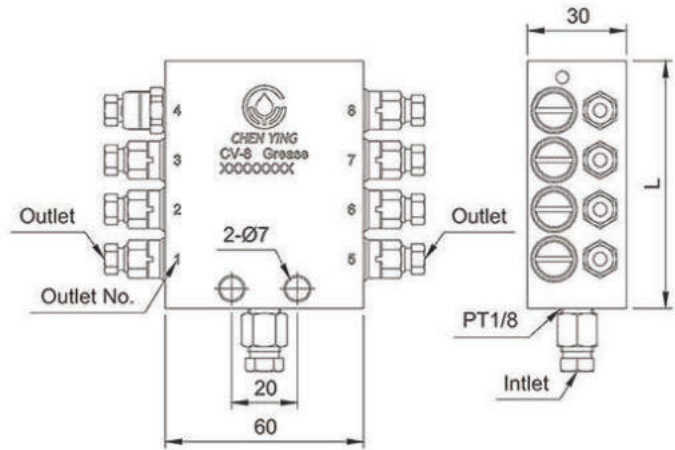

Dimensional Drawing of CV-8-6-4-1

◆ Features

- CV progressive feeder can deliver a fixed volume of lubricant to each lubrication point. The standard discharge volume is 0.18cc per stroke. The outlets of the CV progressive feeder can be combined for a larger discharge volume on request.
- Each outlet of a CV progressive feeder has one piston inside. The lubricant flow moves each piston, and CV progressive feeder discharges lubricant one by one outlet to complete a circulation cycle.
- Forbid to plug any CV progressive feeder outlet, or it cannot discharge lubricant functionally.
- Each standard CV progressive feeder has an indicator pin that moves in and out once as a completed circulation cycle. Monitoring can be done visually or electronically with a sensor or proximity switch.
- There are two types of inlet and outlet adapters: compression bushings with sleeves and quick couplings. Please refer to page 110 for connecting and disconnecting the quick couplings.

◆ Order Code

CV-8 — 6 — 4 — 1 — ※

Model	Inlet Bore		Lubricant	
CV-6	6	Ø6	0	Oil
CV-8	8	Ø8	1	Grease
CV-10	6Q	Ø6 Quick Coupling		
CV-12				
CV-14				
CV-16				
CV-18				
CV-20				

Model	Outlet Bore		Special Request	
CV-14	4	Ø4	A	Add a Sensor Switch (for Grease CV Only)
CV-16	6	Ø6	B	Add a Proximity Switch (for Oil CV Only)
CV-18	4Q	Ø4 Quick Coupling		
CV-20	6Q	Ø6 Quick Coupling		

◆ Dimensional Data

Model	Outlet Num.	Inlet Bore	Outlet Bore	L (mm)	N.W. (g)
CV-6	6	Ø6 (M10xP1.0) or Ø8 (M14xP1.5)	Ø4 (M8xP1.0) or Ø6 (M10xP1.0)	60	407
CV-8	8			75	514
CV-10	10			90	628
CV-12	12			105	686
CV-14	14			120	840
CV-16	16			135	937
CV-18	18			150	1062
CV-20	20			165	1169

※ Standard Type: inlet bore Ø6, and outlet bore Ø4

◆ Technical Data

Suitable Lubricant	Suitable Viscosity	Operating Pressure Range	Discharge Volume	Suitable Lubricators
Oil	32-220 cSt@40°C	5-30 kgf/cm ²	About 0.18cc/Stroke	Resistance Type Oil Lubricators with Discharge Volume Above 500cc/min
Grease	NLGI 000-2	15-150 kgf/cm ²	About 0.18cc/Stroke	Resistance Type Grease Lubricators

◆ Related Products



Proximity Switch



Sensor Switch



CV-12-6-4-1-A



CV-12-6Q-4Q-1

CV Progressive Feeder

◆ How CV Progressive Feeder Works (Take CV-8 as an example)

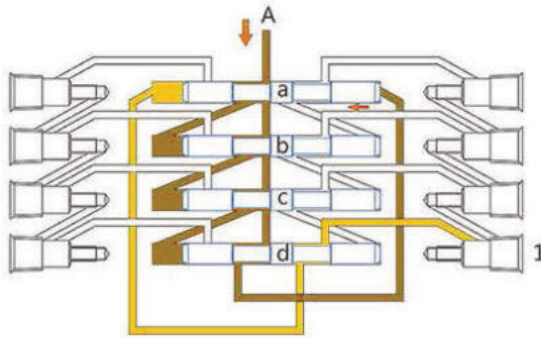

1. The lubricant pressure forces the lubricant to flow into inlet "A", fills up each piston hole with lubricant, and pushes pistons to move to each tap stop.
2. Piston "a" moves to the left that makes the lubricant changing the flow direction. The original lubricant of the left side piston "a" flows through piston "d" and keeps moving to the first outlets.

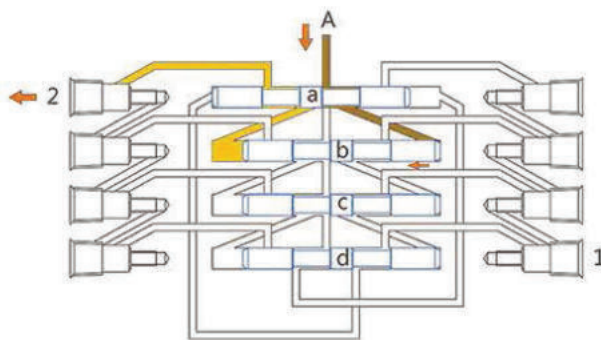

3. After the flow direction is changed, the lubricant moves toward piston "b" which forces piston "b" to move toward the left. The original lubricant of the left side piston "b" flows through piston "a", and keeps moving to the second outlet.

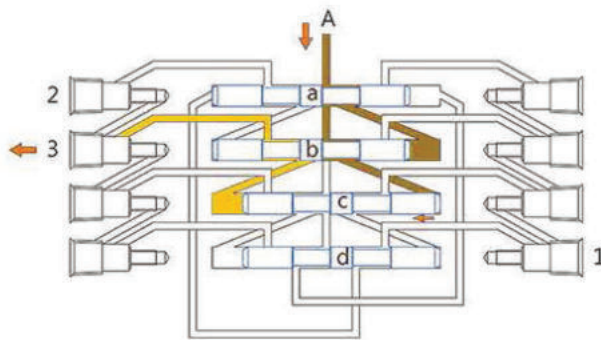

4. After the flow direction is changed, the lubricant moves toward piston "c" which forces piston "c" to move toward the left. The original lubricant of the left side piston "c" flows through piston "b", and keeps moving to the third outlet.

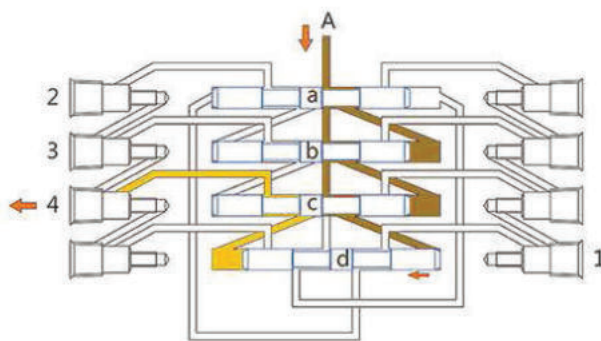

5. After the flow direction is changed, the lubricant moves toward piston "d" which forces piston "d" to move toward the left. The original lubricant of the left side piston "d" flows through piston "c", and keeps moving to the fourth outlet.

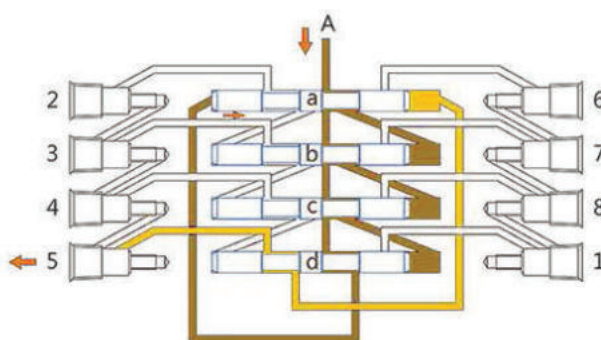

6. After the flow direction is changed, the lubricant moves toward piston "a" which forces piston "a" to move toward the left. The original lubricant of the right side piston "a" flows through piston "d", and keeps moving to the fifth outlet. The left side circulation is completed.
7. The right-side circulation is the same as the left-side circulation.

Proportion Adapter

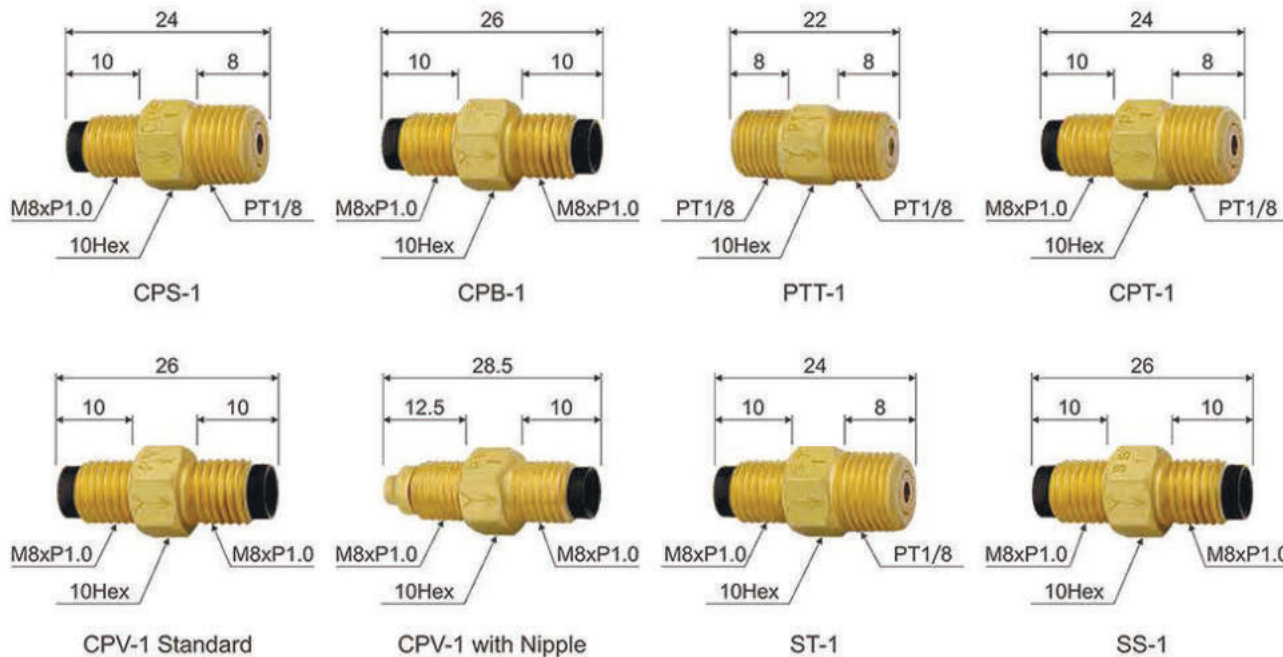

◆ Features

1. Proportion adapters work with resistance type lubricators and open-straight type distributors, such as A types, AE types, B types, CB types, AE grease nipple types, and BB grease nipple types.
2. The flow between lubrication points can be more accurate by applying proportion adapters of different flow rates.
3. The flow rate of the proportion adapter is proportional. For example, under the same usage conditions, the flow rate of CPS-3 is about twice that of CPS-2; the flow rate of ST-2 is about four times that of ST-0.
4. Please use a clean lubricant to avoid the accumulation of impurities inside the proportion adapter, which may affect the flow of discharge volume or block the lubricant from flowing through the adapters.

◆ Technical Data and Dimensional Data

Model	Inlet (Outer Thread)	Outlet (Outer Thread)	Suitable Lubricators	Suitable Viscosity	Flow Code	Flow Rate	Internal Structure	Backflow Prevention	N.W. (g)						
CPS	M8xP1.0	PT1/8	Resistance Type Grease Lubricators	Grease NLGI 000-0	1	[1]	Flow Restrictor	X	10						
CPB	M8xP1.0	M8xP1.0							9						
PTT	PT1/8	PT1/8							2	[2]	Less ↑ Discharge Volume ↓ More	10			
CPT	M8xP1.0	PT1/8							3	[4]		10			
CPV Standard	M8xP1.0	M8xP1.0	4	[8]	9										
CPV with Nipple	M8xP1.0	M8xP1.0	Resistance Type Oil Lubricators	Oil 32-90 cSt@40°C	5	[16]	Flow Hole	O	9						
ST	M8xP1.0	PT1/8							0	[2]	Less ↑ Discharge Volume ↓ More	9			
SS	M8xP1.0	M8xP1.0							Resistance Type Oil Lubricators	Oil 32-90 cSt@40°C		1	[4]	O	9
			3	[16]											
4	[32]	8													
			5	[64]											

◆ Order Code (CPS, CPB, PTT, CPT, CPV)

◆ Order Code (ST, SS)

CPS ——— 1 ——— ✖

Model	Outer Thread
CPS	M8xPT1/8
CPB	M8xM8
PTT	PT1/8xPT1/8
CPT	M8xPT1/8
CPV Standard	M8xM8
CPV with Nipple	M8xM8

Code	Flow Rate
1	[1]
2	[2]
3	[4]
4	[8]
5	[16]

Special Request	
S	Add Compression Sleeve and Nut

ST ——— 1 ——— ✖

Model	Outer Thread
ST	M8xPT1/8
SS	M8xM8

Code	Flow Rate
0	[2]
1	[4]
2	[8]
3	[16]
4	[32]
5	[64]

Special Request	
S	Add Compression Sleeve and Nut

Oil Meter Adapter

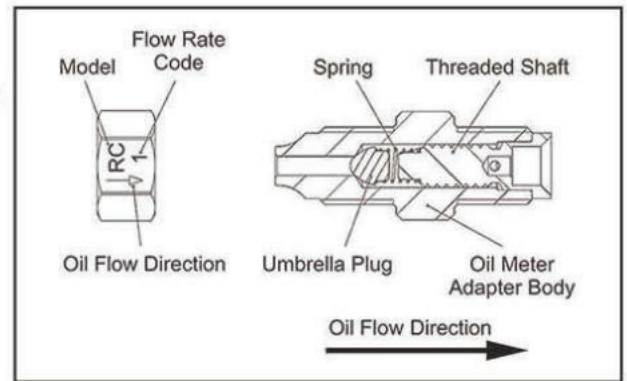
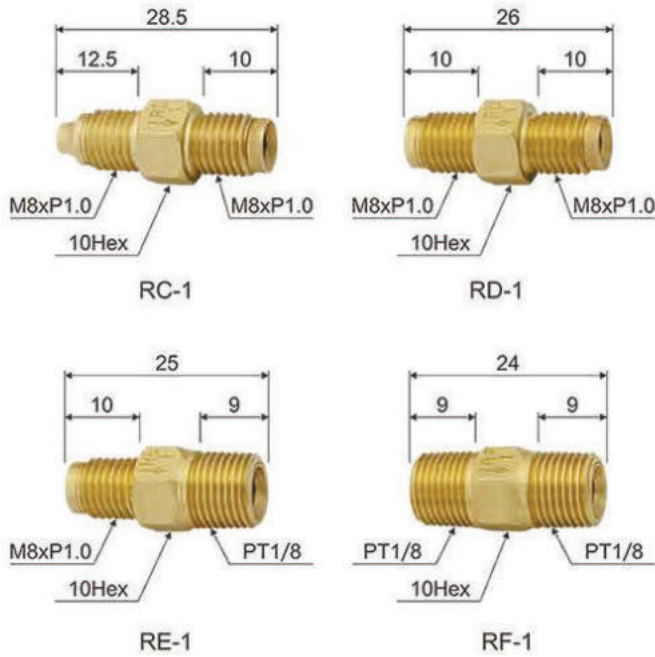

Internal Structure of Oil Meter Adapter

◆ Features

1. The oil meter adapter can deliver proper and exact volume to each lubrication point by calculating the total discharge volume needed. Based on the above calculation result, select the suitable lubricator model to work together.
2. The total oil consumption of the lubrication points per minute should be less than half of the discharge volume of the lubricator to prevent pressure loss.
3. The main oil pipe should be 6mm or larger to keep the piping system pressurized.
4. The flow rate of the oil meter adapter increases in an arithmetic series. (The flow rate with the flow code 00 is 1/3 of the flow code 0.)
5. Oil meter adapter obtained the Taiwan Utility Patent No. M571928.
6. Forbid to add used oil or any volatile oil to avoid the accumulation of impurities inside the oil meter adapter, which may affect the flow of discharge volume or block the oil from flowing through the adapters.

◆ Technical Data and Dimensional Data

Model	Inlet (Outer Thread)	Outlet (Outer Thread)	Suitable Lubricators	Operating Pressure Range	Suitable Viscosity	Flow Code	Flow Rate	Internal Structure	Backflow Prevention	N.W. (g)
RC	M8 with Nipple x P1.0	M8xP1.0	Resistance Type Oil Lubricators	2-20 kgf/cm ²	Oil 32-90 cSt@40°C	00	[1]	Flow Restrictor	O	9.6
RD	M8xP1.0	M8xP1.0				0	[3]			
RE	M8xP1.0	PT1/8				1	[6]			
RF	PT1/8	PT1/8				2	[9]			
			3	[12]						
			4	[15]					11.0	
			5	[18]						13.0

◆ Order Code

RC	00	※		
Model	Outer Thread	Code	Flow Rate	Special Request
RC	M8 with Nipple x M8	00	[1]	S Add Compression Sleeve and Nut
RD	M8 x M8	0	[3]	
RE	M8 x PT1/8	1	[6]	
RF	PT1/8 x PT1/8	2	[9]	
		3	[12]	
		4	[15]	
		5	[18]	

CAB Type Volume Distributor (Standard Type & Quick Coupling Type)

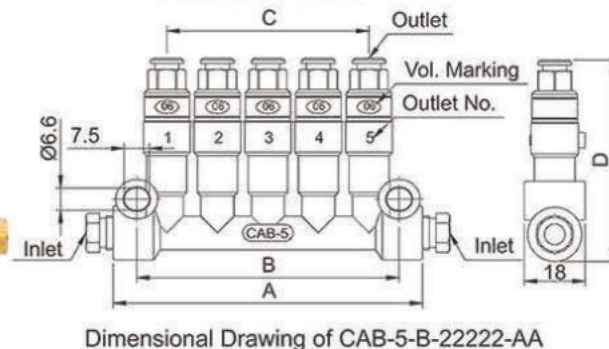
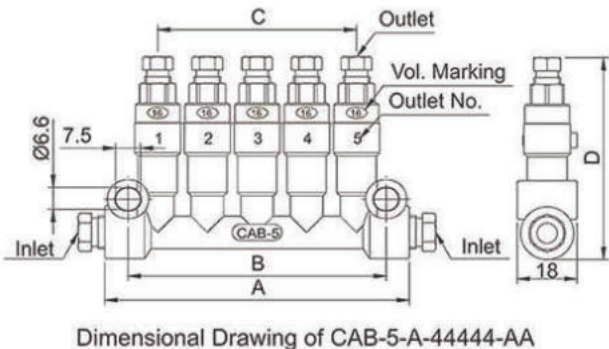

◆ Features

1. CAB type volume distributor can deliver a precisely metered quantity of oil to each lubrication point.
2. CAB needs to work with a pressure-relief type oil lubricator and discharges oil during the operation time of the lubricator.
3. There are two types of outlet adapters available; one is compression bushing and sleeve (standard type), and another is quick coupling.
4. Recommend using quick coupling with N12 nylon pipe. Please refer to page 110 for connecting and disconnecting quick couplings.

◆ Dimensional Data & Technical Data

Model	Outlet Num.	Inlet Bore	Outlet Bore	A (mm)	B (mm)	C (mm)	D (mm)	Discharge Volume/Stroke (Vol. Marking)	Operating Pressure Range	Suitable Viscosity	N.W. (g)	
											Standard Type	Quick Coupling Type
CAB-1A	1	Outer Thread PT1/8	ø4 (M8xP1.0)	ø13.5	-	-	51	0.03cc (03) 0.06cc (06) 0.10cc (10) 0.16cc (16)	8-30 kgf/cm ²	Oil 32-90 cSt@40°C	30	37
CAB-1B	1	Outer Thread ø4(M8xP1.0)		ø13.5	-	-	53				30	39
CAB-2	2	ø6 (M10xP1.0)	ø4 (M8xP1.0)	47	33	15	60				117	121
CAB-3	3			62	48	30	60				154	161
CAB-5	5			92	78	60	60				229	239
CAB-6	6			107	93	75	60				269	272
CAB-8	8			151	102	105	60				350	365

◆ Order Code

CAB — 5 — A — 1-1-1-1-1 — A-A
Left Side Right Side

Code	Outlet Number
1A	1 (PT1/8)
1B	1 (M8xP1.0)
2	2
3	3
5	5
6	6
8	8

Code	Outlet Adapter Type
A	Compression Bushing & Sleeve
B	Quick Coupling

Code	Discharge Volume
0	Plugged
1	0.03cc
2	0.06cc
3	0.10cc
4	0.16cc

Code	Inlet Fittings
A	ø6 Compression Bushing & Sleeve
D	ø6 Quick Coupling
G	Closure Plug
X	Without Fittings
S	Special Request

※ Except for CAB-1A and CAB-1B, others all need to provide the order code for inlet fittings.

CBB Type Volume Distributor



◆ Features

1. CBB type volume distributor can deliver a precisely metered quantity of oil to each lubrication point.
2. CBB needs to work with a pressure-relief type oil lubricator and discharges oil during the operation time of the lubricator.

◆ Dimensional Data & Technical Data

Model	Outlet Num.	Inlet Bore	Outlet Bore	A (mm)	B (mm)	C (mm)	D (mm)	Discharge Volume/Stroke (Volume Marking)	Operating Pressure Range	Suitable Viscosity	N.W. (g)
CBB-1	1	Outer Thread M10xP1.0	ø4 (M8xP1.0)	ø15	-	-	75	0.1cc (1)	8-30 kgf/cm ²	Oil 32-90 cSt@40°C	79
CBB-2	2	ø6 (M10xP1.0)		53	37	17	80	0.2cc (2)			178
CBB-3	3			70	54	34	80	0.3cc (3)			250
CBB-5	5			104	88	68	80	0.4cc (4)			410
								0.5cc (5)			

◆ Order Code

CBB — 5 — A — 1 — 1 — 1 — 1 — 1 — A — A
Left Side Right Side

Code	Outlet Number
1	1
2	2
3	3
5	5

Code	Outlet Adapter Type
A	Compression Bushing & Sleeve

Code	Discharge Volume
0	Plugged
1	0.1cc
2	0.2cc
3	0.3cc
4	0.4cc
5	0.5cc

Code	Inlet Fittings
A	ø6 Compression Bushing & Sleeve
G	Closure Plug
X	Without Fittings
S	Special Request

※ Except for CBB-1, others all need to provide the order code for inlet fittings.

CCB Type Large Volume Distributor



CCB-1-A-6

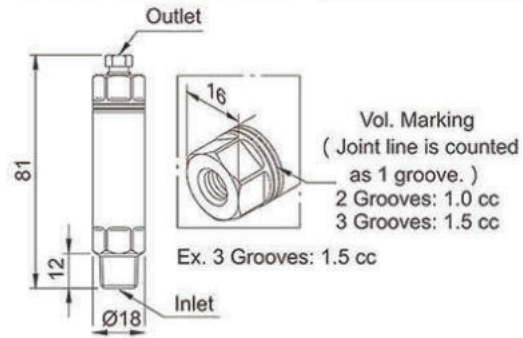

Dimensional Drawing of CCB-1-A-6



CCB-4-A-6666-AG

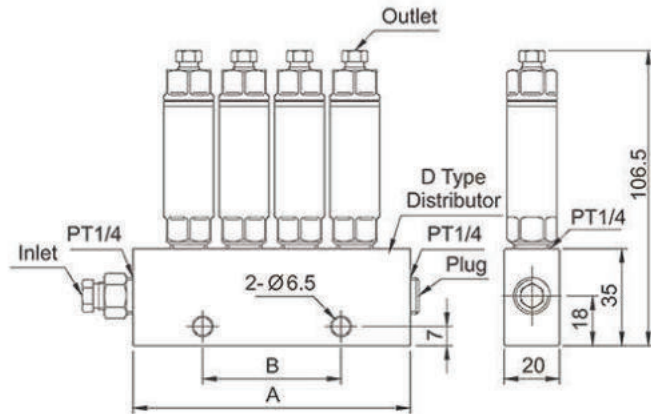

Dimensional Drawing of CCB-4-6666-AG

◆ Features

1. CCB type large volume distributor can deliver a precisely metered quantity of oil to each lubrication point.
2. CCB needs to work with a pressure-relief type oil lubricator and discharges oil during the operation time of the lubricator. The minimum interval time setting is 5 minutes.
3. There are two options for the discharge volume of CCB: two grooves stand for 1.0cc, and three grooves stand for 1.5cc.
4. CCB is designed as a singular outlet unit, which can be assembled with a D type distributor to increase the outlet number from one to eight outlets.

◆ Dimensional Data & Technical Data

Model	Outlet Num.	Inlet Bore	Outlet Bore	A (mm)	B (mm)	Discharge Volume/Stroke (Volume Marking)	Operating Pressure Range	Suitable Viscosity	N.W. (g)
CCB-1	1	Outer Thread PT1/4	Ø4 (M8xP1.0)	-	-	1.0cc (2 Grooves) 1.5cc (3 Grooves)	8-30 kgf/cm ²	Oil 32-90 cSt@40°C	113
CCB-2	2	Inner Thread PT1/4		60	30				341
CCB-3	3			80	30				486
CCB-4	4			100	50				632
CCB-5	5			120	70				772
CCB-6	6			140	90				917
CCB-7	7			160	110				1059
CCB-8	8			180	130				1203

◆ Order Code

CCB — 4 — A — 6 — 6 — 6 — 6 — A — G
 Left Side Right Side

Code	Outlet Number
1	1
2	2
3	3
4	4
5	5
6	6
7	7
8	8

Code	Outlet Adapter Type
A	Compression Bushing & Sleeve

Code	Discharge Volume
6	1.0cc
7	1.5cc

Code	Inlet Fittings
A	Ø6 Straight Adapter with Compression Bushing and Sleeve
B	Ø8 Straight Adapter with Compression Bushing and Sleeve
G	Closure Plug
X	Without Fittings
S	Special Request

※ Except for CCB-1, others all need to provide the order code for inlet fittings.

CDB Type Volume Distributor



CDB-5-A-11111-AA

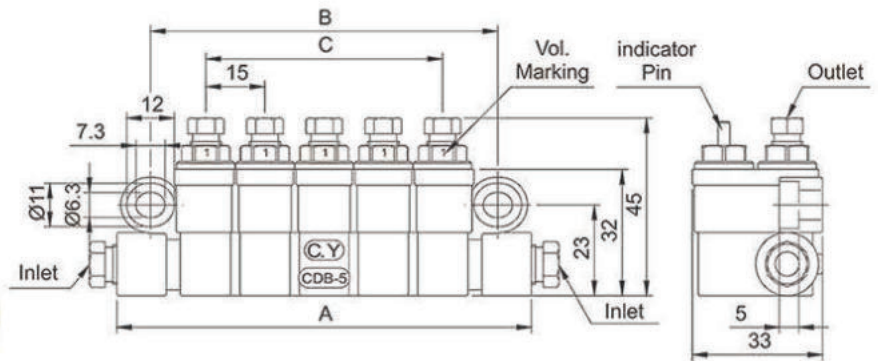

Dimensional Drawing of CDB-5-A-11111-AA

◆ Features

1. CDB type large volume distributor can deliver a precisely metered quantity of oil to each lubrication point.
2. CDB needs to work with a pressure-relief type oil lubricator and discharges oil during the interval time of the lubricator.
3. Each outlet of CDB has an indicator pin that enables the user to monitor the oil discharging visually. It can optionally add a sensor switch to the indicator pin for an electronic signal.
4. CDB with an outlet of discharging volume 0.5 cc can add a sensor switch. The user can either set up NO contact, NC contact, or both upon need. When it is set as NO contact, it sends a signal during the operation time of the lubricator. When it is set as NC contact, it sends a signal during the interval time of the lubricator.

◆ Dimensional Data & Technical Data

Model	Outlet Num.	Inlet Bore	Outlet Bore	A (mm)	B (mm)	C (mm)	Discharge Volume/Stroke (Volume Marking)	Operating Pressure Range	Suitable Viscosity	N.W. (g)
CDB-1	1	Ø6 (M10xP1.0)	Ø4 (M8xP1.0)	45	28	-	0.1cc (1)	8-30 kgf/cm ²	Oil 32-90 cSt@40°C	133
CDB-2	2			60	43	15	0.2cc (2)			213
CDB-3	3			75	58	30	0.3cc (3)			288
CDB-4	4			105	88	60	0.4cc (4)			445
CDB-5	5						0.5cc (5)			

◆ Order Code

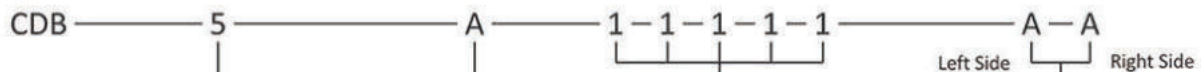

Code	Outlet Number
1	1
2	2
3	3
5	5

Code	Outlet Adapter Type
A	Compression Bushing & Sleeve

Code	Discharge Volume
0	Plugged
1	0.1cc
2	0.2cc
3	0.3cc
4	0.4cc
5	0.5cc
5A	0.5cc+Sensor Switch

Code	Inlet Fittings
A	Ø6 Compression Bushing & Sleeve
G	Closure Plug
X	Without Fittings
S	Special Request

T Type Volume Distributor (Standard Type & Quick Coupling Type)



T-500-A-33333-AA

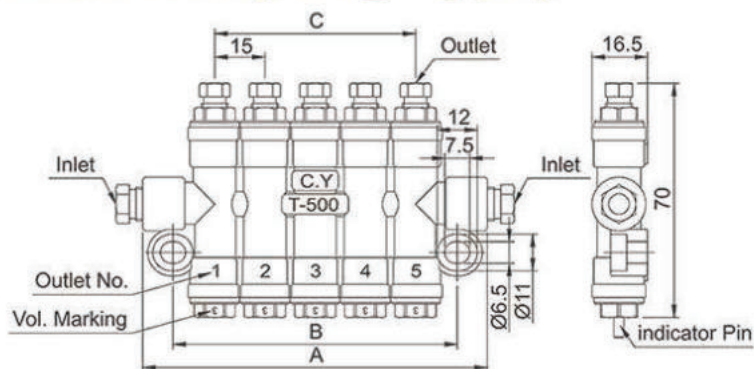

Dimensional Drawing of T-500-A-33333-AA



T-500-B-33333-AA

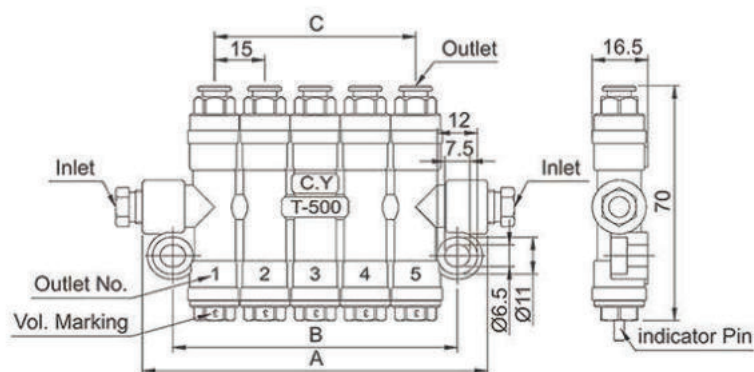

Dimensional Drawing of T-500-B-33333-AA

◆ Features

1. T type volume distributor can deliver a precisely metered quantity of oil to each lubrication point.
2. T type volume distributor needs to work with a pressure-relief type oil lubricator and discharges oil during the interval time of the lubricator.
3. Each outlet of T type volume distributor has an indicator pin that enables the user to monitor the oil discharging function visually. It can optionally add a sensor switch to the indicator pin for an electronic signal.
4. The standard proximity switch is NC contact. It sends a signal when it does not detect the movement of the indicator pin. NO contact is available on request.
5. T type volume distributor with an outlet of discharging volume 0.5 cc can add a sensor switch. The user can either set up NO contact, NC contact, or both upon need.
6. There are two types of outlet adapters available; one is compression bushing and sleeve (standard type), and another is quick coupling.
7. Recommend using quick coupling with N12 nylon pipe. Please refer to page 110 for connecting and disconnecting quick coupling.

◆ Dimensional Data & Technical Data

Model	Outlet Num.	Inlet Bore	Outlet Bore	A (mm)	B (mm)	C (mm)	Discharge Volume/Stroke (Vol. Marking)	Operating Pressure Range	Suitable Viscosity	N.W. (g)	
										Standard Type	Quick Coupling Type
T-200	2	Ø6 (M10xP1.0)	Ø4 (M8xP1.0)	58	40	15	0.1cc (1) 0.2cc (2) 0.3cc (3) 0.4cc (4) 0.5cc (5)	8-30 kgf/cm ²	Oil 32-90 cSt@40°C	166	180
T-300	3			73	55	30				225	232
T-400	4			88	70	45				281	291
T-500	5			103	85	60				342	353
T-600	6			118	100	75				397	413
T-700	7			133	115	90				463	480

T Type Volume Distributor (Standard Type & Quick Coupling Type)

◆ Order Code

T — 500 — A — 1 — 4 — 4 — 4 — 4 — A — A
 Left Side Right Side

Code	Outlet Number
200	2 Outlets
300	3 Outlets
400	4 Outlets
500	5 Outlets
600	6 Outlets
700	7 Outlets

Code	Outlet Adapter Type
A	Compression Bushing & Sleeve
B	Quick Coupling

Code	Discharge Volume
0	Plugged
1	0.1cc
2	0.2cc
3	0.3cc
4	0.4cc
5	0.5cc

Code	Discharge Volume
5A	0.5cc+Sensor Switch
1B	0.1cc+Proximity SW
2B	0.2cc+Proximity SW
3B	0.3cc+Proximity SW
4B	0.4cc+Proximity SW
5B	0.5cc+Proximity SW

Code	Inlet Fittings
A	∅6 Compression Bushing & Sleeve
D	∅6 Quick Coupling
G	Closure Plug
X	Without Fittings
S	Special Request

◆ How to Connect and Disconnect A Quick Coupling

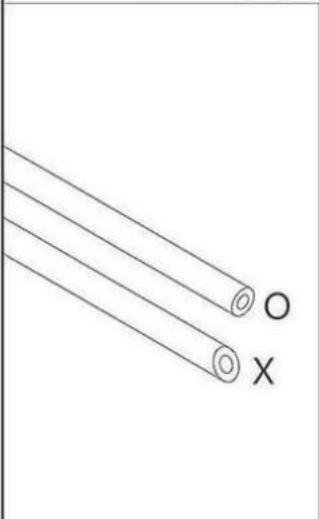
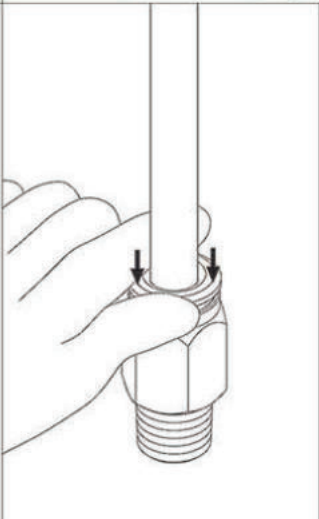
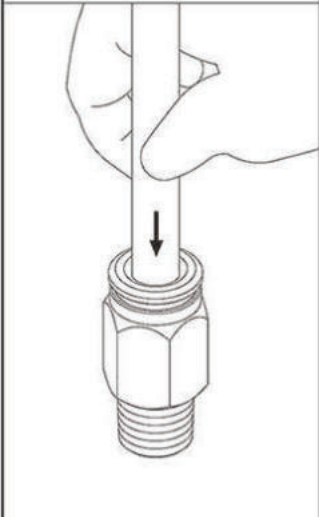
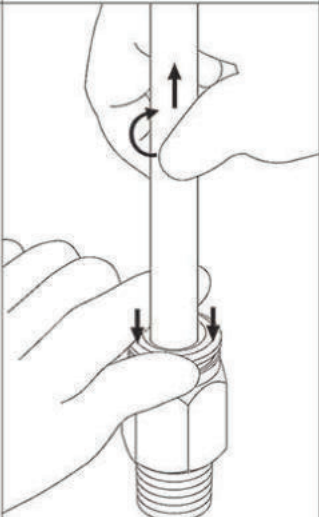
Connecting Pipe with Quick Coupling		Disconnecting Pipe with Quick Coupling	
 <p>1. Make sure the cutting edge of the pipe is smooth and flat.</p>	 <p>1. Push down the top of the quick coupling with the thumb and index finger to loosen it from the pipe.</p>		
 <p>2. Insert the pipe into the quick coupling then you will hear two click sounds. 3. Pull the pipe to check if it is securely locked.</p>	 <p>2. Use the other hand to push the pipe into the quick coupling gently. Then, rotate the pipe for approximately a 90-degree angle and simultaneously pull the pipe out.</p>		

CO / OA Type Oil-Air Volume Distributor

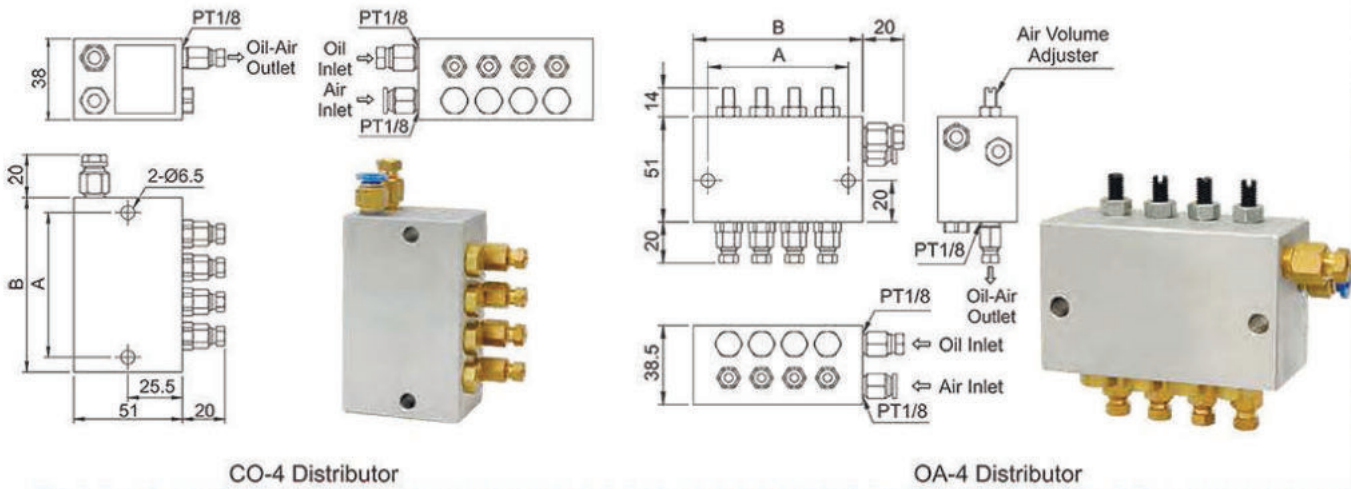

CO-4 Distributor

OA-4 Distributor

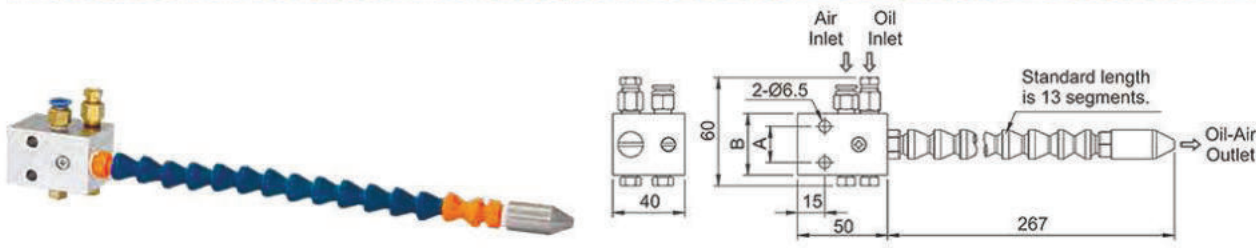

CO-1 Spray Gun

◆ Features

- CO and OA volume distributors can deliver a precisely metered quantity of oil-air mixture to each lubrication point.
- CO and OA volume distributors have to work with COA pressure-relief type oil lubricators and discharge oil-air mixture during the operation time of the lubricator.
- CO and OA volume distributors mix a metered quantity of oil with an air stream to form an oil-air mixture, which can spray to the lubrication points evenly and save oil consumption.
- The air volume of the CO is fixed, but the OA is adjustable so that the user can adjust the air volume for each outlet to have even air for different pipe lengths.
- CO-1 spray gun is suitable for cutting machines for micro lubrication and cooling effects. The standard length of the adjustable coolant hose is 13 segments, but the number of segments can be customized upon request.

◆ Dimensional Data & Technical Data

Model	Outlet Num.	Air Inlet Bore	Oil Inlet Bore	Oil-Air Outlet Bore	A (mm)	B (mm)	Discharge Volume/Stroke	Operating Oil Pressure Range	Operating Air Pressure Range	Suitable Viscosity	N.W. (g)
CO-1 Spray Gun	1	∅6xPT1/8	∅6 (M10xP1.0)	-	20.0	34	0.01cc	15-30 kgf/cm ²	4-7 kgf/cm ² (Air Volume Fixed)	Oil 10-90 cSt@40°C	271
CO-1	1	∅6xPT1/8	∅6 (M10xP1.0)	∅4 (M8xP1.0)	20.0	34	0.03cc				209
CO-2	2				36.5	50	0.06cc				308
CO-3	3				52.0	66	0.10cc				408
CO-4	4				68.0	82	0.16cc				506
CO-5	5				85.0	99		617			
OA-1	1	∅6xPT1/8	∅6 (M10xP1.0)	∅4 (M8xP1.0)	20.0	34	0.03cc	15-30 kgf/cm ²	4-7 kgf/cm ² (Air Volume Adjustable)	Oil 10-90 cSt@40°C	217
OA-2	2				36.5	50	0.06cc				324
OA-3	3				52.0	66	0.10cc				431
OA-4	4				68.0	82	0.16cc				537
OA-5	5				85.0	99					656

◆ Order Code

CO	4	1	2	3	4	
Model	Outlet Number			Discharge Volume		
CO Air Volume Fixed	1	1 Outlet	3	3 Outlets	5	5 Outlets
OA Air Volume Adjustable	2	2 Outlets	4	4 Outlets		
	1	0.03cc	3	0.10cc		
	2	0.06cc	4	0.16cc		

OC Type Oil-Air Volume Distributor (Standard Type & Quick Coupling Type)



OC-4-A-2222

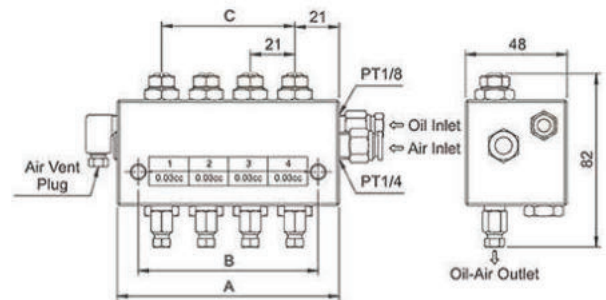

Dimensional Drawing of OC-4-A-2222

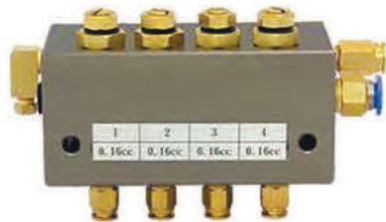

OC-4-B-5555

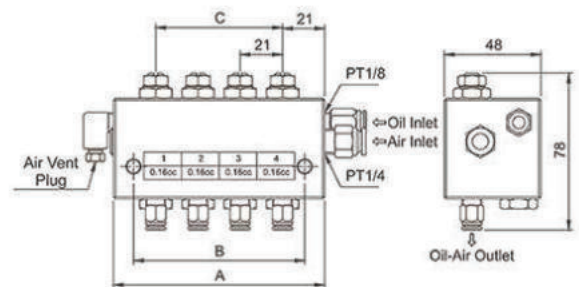

Dimensional Drawing of OC-4-B-5555

◆ Features

1. OC volume distributor can deliver a precisely metered quantity of oil to each lubrication point.
2. OC has to work with a pressure-relief type oil lubricator and discharge oil during the operation time of the lubricator.
3. OC mixes a metered quantity of oil with an air stream to form an oil-air mixture, which can spray to the lubrication points evenly and save oil consumption.
4. The air volume of OC is adjustable so that the user can adjust the air volume for each outlet to have even air for different pipe lengths.
5. OC is suitable for cutting machines for micro lubrication and cooling effects. For example, POA or PNC03 lubricator with OC can apply in lubricating a spindle with a speed between $15,000\text{min}^{-1}$ to $20,000\text{min}^{-1}$.
6. There are two adapter options for inlets and outlets of OC: (1) compression bushing and sleeve type; (2) quick coupling type.
7. Recommend using quick coupling with N12 nylon pipe. Please refer to page 110 for connecting and disconnecting quick couplings.

◆ Dimensional Data & Technical Data

Model	Outlet Num.	Air Inlet Bore	Oil Inlet Bore	Oil-Air Outlet Bore	A (mm)	B (mm)	C (mm)	Discharge Volume Per Stroke	Operating Oil Pressure Range	Operating Air Pressure Range	Suitable Viscosity	N.W. (g)	
												Standard Type	Quick Coupling Type
OC-2	2	∅8xPT1/4	∅6 (M10xP1.0)	∅4 (M8xP1.0)	63	43	21	0.01cc	20-30 kgf/cm ²	3.5-7 kgf/cm ²	Oil 10-68 cSt@40°C	527	523
OC-3	3				84	64	42	0.03cc				706	700
OC-4	4				105	85	63	0.06cc				884	874
OC-5	5				126	106	84	0.10cc				1064	1051
OC-6	6				147	127	105	0.16cc				1241	1229

OC Type Oil-Air Volume Distributor (Standard Type & Quick Coupling Type)

◆ Order Code

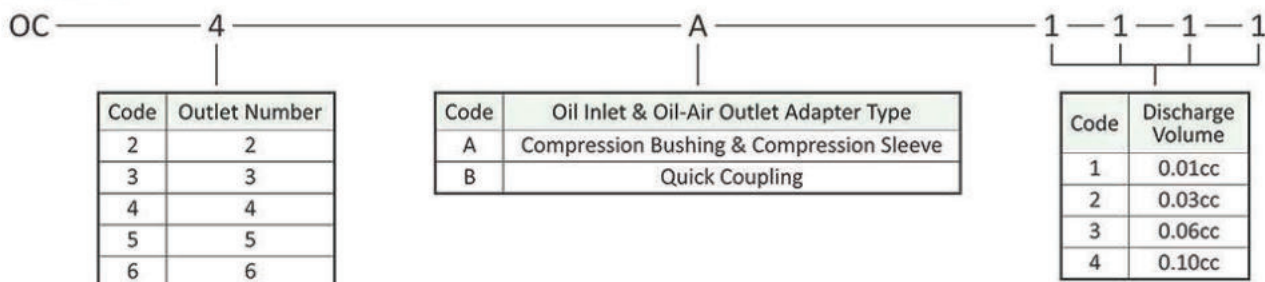

◆ POA Lubricator and OC Distributor Oil-Air Lubrication System Layout

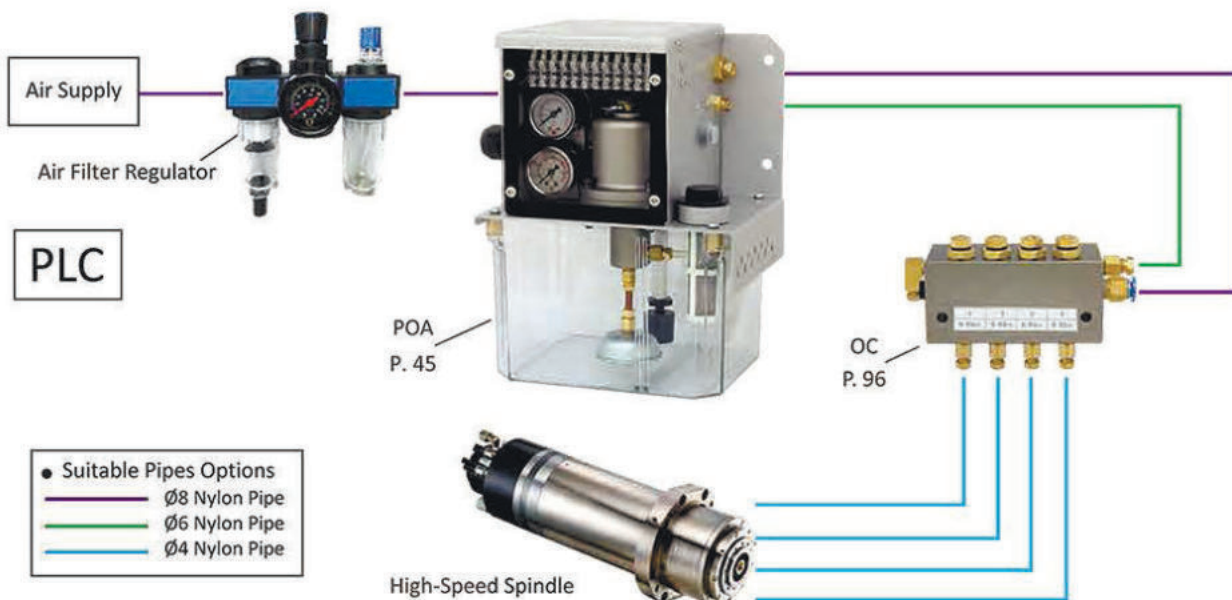

CFB Type Grease Volume Distributor (Standard Type & Quick Coupling Type)



CFB-05-A-55522-AG

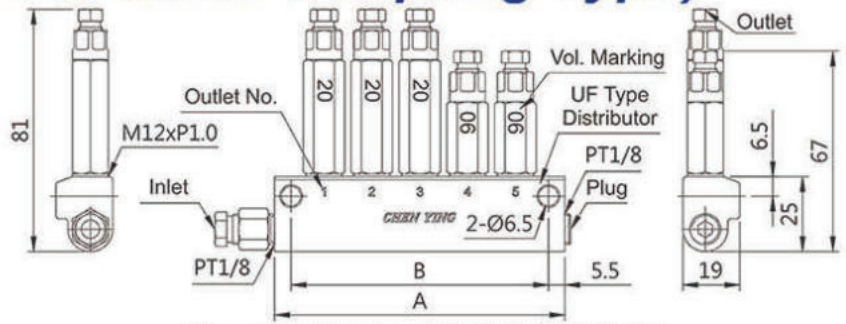

Dimensional Drawing of CFB-05-A-55522-AG



CFB-05-B-55522-AG

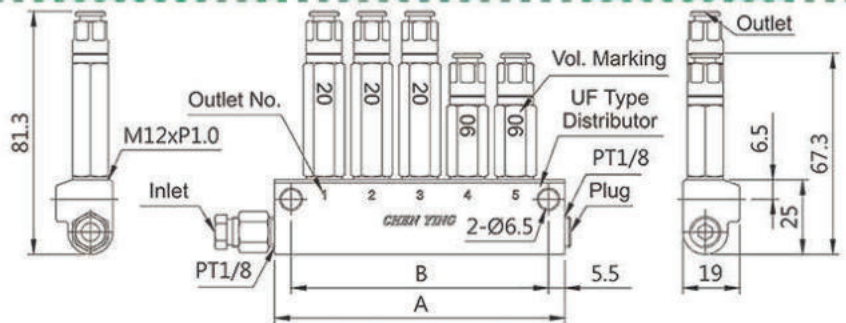

Dimensional Drawing of CFB-05-B-55522-AG

◆ Features

1. CFB volume distributor can deliver a precisely metered quantity of grease to each lubrication point.
2. CFB has to work with a pressure-relief type grease lubricator and discharge grease during the operation time of the lubricator.
3. CFB is designed as a singular outlet unit, which can be assembled with a UF type distributor to increase the outlet number from one to twelve outlets.
4. The main pipe should be a metal pipe or PPST50 high-pressure flexible hose. The inner diameter pipe should be larger than 4mm for NLGI0 grease.
5. There are two adapter options for inlets and outlets: (1) compression bushing and sleeve type; (2) quick coupling type.
6. Recommend using quick coupling with N12 nylon pipe. Please refer to page 110 for connecting and disconnecting quick couplings.

◆ Dimensional Data & Technical Data of CFB Distributor

Model	Outlet Num.	Outlet Bore	Operating Pressure Range	Suitable Viscosity	Discharge Volume/Stroke (Vol. Marking)	N.W. (g)	
						Standard Type	Quick Coupling Type
CFB-01	1	Ø4 (M8xP1.0)	30-120 kgf/cm ²	Grease NLGI 000-0	0.03cc (03)	35.3	40.1
					0.06cc (06)	35.1	39.9
					0.10cc (10)	34.9	39.7
					0.16cc (16)	34.4	39.2
					0.20cc (20)	48.3	53.1
					0.30cc (30)	47.5	52.3
					0.40cc (40)	46.8	51.6
					0.50cc (50)	46.0	50.8

※ CFB-01 has to be assembled with UF-01.

◆ Order Code



Outlet Number			
01	1 Outlet	07	7 Outlets
02	2 Outlets	08	8 Outlets
03	3 Outlets	09	9 Outlets
04	4 Outlets	10	10 Outlets
05	5 Outlets	11	11 Outlets
06	6 Outlets	12	12 Outlets

Outlet Adapter Type	
A	Compression Bushing & Sleeve
B	Quick Coupling

Discharge Volume			
0	Plugged	5	0.20cc
1	0.03cc	6	0.30cc
2	0.06cc	7	0.40cc
3	0.10cc	8	0.50cc
4	0.16cc		

Inlet Fittings	
A	Ø6 Straight Adapter with Compression Bushing & Sleeve
B	Ø8 Straight Adapter with Compression Bushing & Sleeve
D	Ø6 Quick Straight Coupling
G	Closure Plug
X	Without Fittings
S	Special Request

◆ Dimensional Data of UF Distributor

Model	Outlet Num.	Inlet Bore	A (mm)	B (mm)	N.W. (g)
UF-01	1	Inner Thread PT1/8	33	22	24.3
UF-02	2		49	38	38.8
UF-03	3		65	54	50.6
UF-04	4		81	70	64.2
UF-05	5		97	86	77.3
UF-06	6		113	102	89.3
UF-07	7		129	118	105.7
UF-08	8		145	134	119.7
UF-09	9		161	150	131.8
UF-10	10		177	166	145.3
UF-11	11		193	182	159.4
UF-12	12		209	198	172.1

OT Type Spray Gun (Air and Oil / Grease Volume Adjustable)



OT-1-0 (N.W.: 184g)

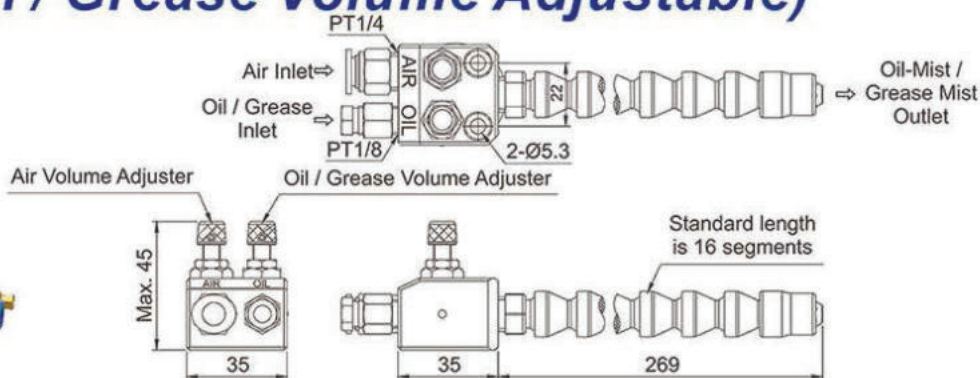

◆ Features

- OT spray gun is suitable for working with resistance oil types, POM oil pneumatic types, and POM-A/POM-AP grease pneumatic types of lubricators.
- OT spray gun has one air inlet and one oil or grease inlet. The oil-mist or grease-mist mixture is superior without dripping.
- The volume of air and oil or grease is adjustable upon the need. Recommend using air pressure supply between 3.5 to 5kgf/cm².
- OT spray gun can add a magnetic base that can attach to any magnetic metal surface and relocate quickly.
- The standard length of the adjustable coolant hose is 16 segments, but the number of segments can be customized upon request.

◆ Order Code

OT — 1 ————— 0 ————— ✕	
Air Inlet Bore	Oil/Grease Inlet Bore
1 Ø8xPT1/4	0 Ø4xPT1/8
	1 Ø6xPT1/8
Special Request	
C Add a Magnetic Base	

✕ If OT works with POM-A and POM-AP grease lubricators, the grease inlet bore should be Ø4xPT1/8.

OTS Spray Gun Set (Air and Oil Volume Adjustable)



OTS-1-0 (N.W.: 1103g)
(OT spray gun with an accessory kit)

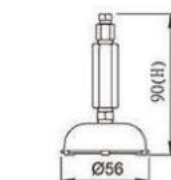
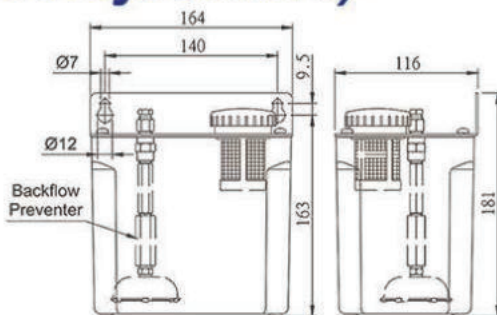

◆ Features

- OTS spray gun set can work independently without a lubricator based on the siphon principle. It is suitable for cutting machines for high-speed micro lubrication and cooling effects.
- Standard OTS has an accessory kit that contains a 2-liter oil tank set, a backflow preventer, and a nylon pipe with a length of either Ø4x300cm or Ø6x150cm, depending on the oil inlet bore is Ø4 or Ø6.
- Recommend using OTS with oil, cutting fluid, or water that the viscosity range is 0-68 cSt@40°C. Forbid to use any volatile oil that contains ester or ethylene glycol.

◆ Installation Layout of OTS-1-0 Spray Gun Set

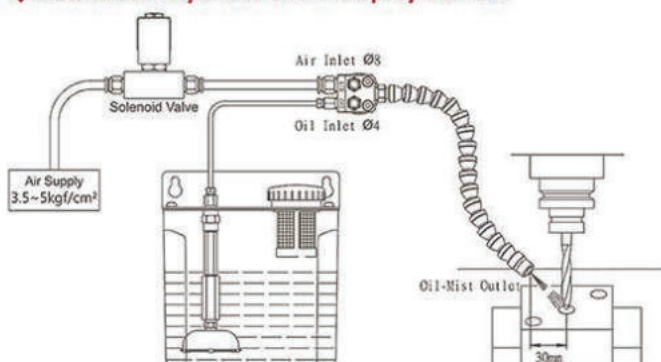

◆ Order Code

OTS — 1 ————— 0 ————— ✕		
Air Inlet Bore	Oil Inlet Bore	Special Request
1 Ø8xPT1/4	0 Ø4xPT1/8	C Add a Magnetic Base D Change Oil Tank from 2L to 4L E Change 2L Oil Tank from Single Outlet to Dual Outlets (Add a Second OT Spray Gun) X W/O 2L Accessory Kit (Only a backflow preventer and a nylon pipe will be supplied.)
	1 Ø6xPT1/8	

OE Type Spray Gun (Three-Nozzle Type with Adjustable Fixed Base)

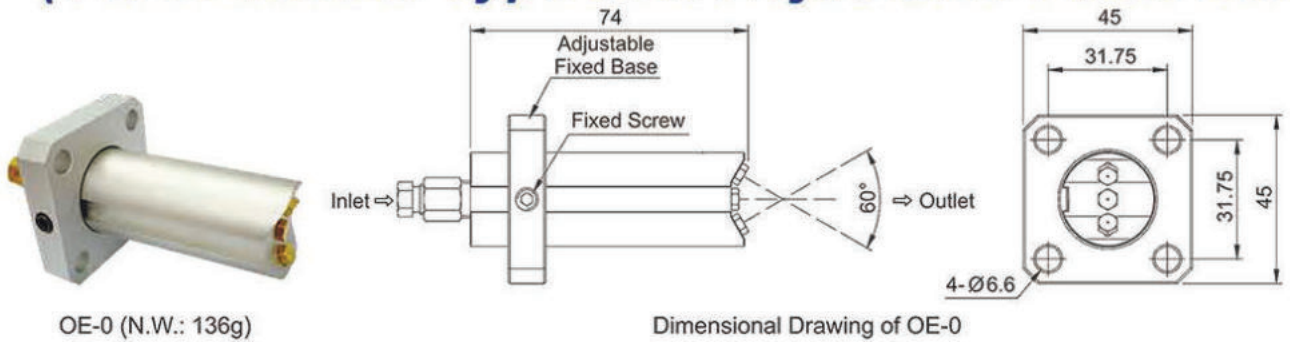

◆ Features

1. OE spray gun has three nozzles that can effectively lubricate and cool the cutting tools. Its adjustable fixed base allows it to be adjusted back and forth according to the position of the cutting tools.
2. The OE with flexible hoses can move along with the cutting tools or workpieces. It is suitable for sawing machines.
3. Recommend working with POM minimum quantity oil lubricator or CEN22 to CEN25 oil-mist lubricators.

◆ Order Code

OE — 0

Inlet Bore	
0	Ø4
1	Ø6

OG Type Spray Gun (Single-Nozzle Type with Copper Pipe)

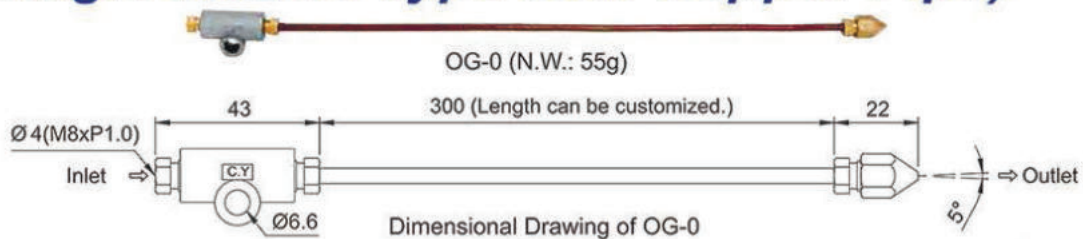

◆ Features

1. OG spray gun is suitable for machines that require fixed lubrication points, such as tapping machines.
2. The standard length of the copper pipe is 300mm, but it can be customized upon request.
3. Recommend working with POM minimum quantity oil lubricator or CEN22 to CEN25 oil-mist lubricators.

◆ Order Code

OG — 0

Inlet Bore	
0	Ø4
1	Ø6

OQ Type Spray Gun (Pipe-in-Pipe Single-Nozzle Type with Adjustable Coolant Hose)

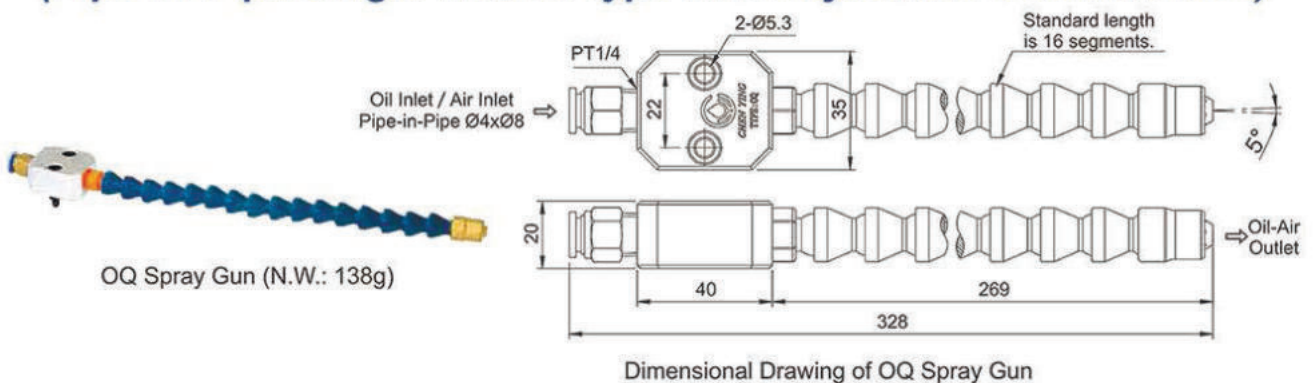

◆ Features

1. The oil and air are mixed in the nozzle of the OG spray gun right before spraying to the lubrication point that creates the superior oil-air mixture.
2. OQ is suitable for machines that require non-fixed lubrication points, such as milling machines.
3. OQ spray gun can add a magnetic base that can attach to any magnetic metal surface and relocate quickly.
4. The standard length of the adjustable coolant hose is 16 segments. The length can be customized upon request.
5. OQ's oil or air inlets must be assembled with Ø4xØ8 pipe-in-pipe, and only work with a POM-type lubricator with an oil outlet bore Ø8.

◆ Order Code

OQ — ☒

Special Request	
C	Add a Magnet Base

Rotary Oil Pump (Clockwise or Anticlockwise)

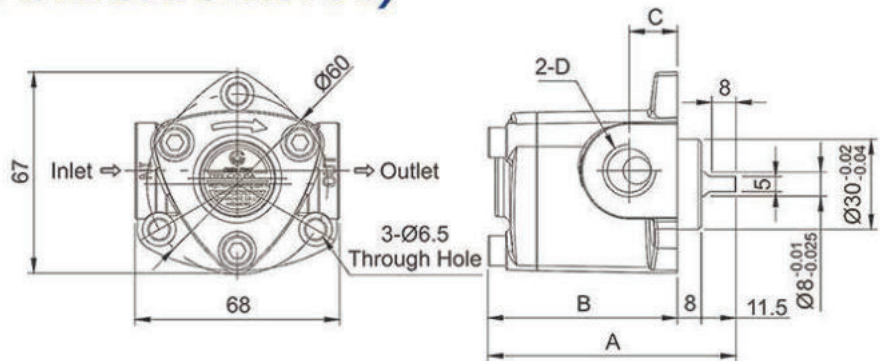

◆ Features

1. Rotary oil pump is also called trochoid oil pump or triangular oil pump. It can only rotate in one direction, clockwise or anticlockwise.
2. Standard rotary oil pump rotates clockwise, but anticlockwise is available on request.
3. The standard rpm is from 1420 to 1720 min⁻¹. Low rpm 450 to 1200 min⁻¹ is only available for CYP-12L type.
4. Recommend adding a CYP-AV adjustable pressure valve to a rotary oil pump. The range of pressure adjustment is 0 to 5kgf/cm².
5. Recommend working with a 1/4HP PMO-0 motor or a PMO-2 motor with connector. It is also suitable for working with CLSA, CLSB, and CLST circulating electric lubricators for lubricating and cooling purposes. It can be applied widely to various machines, such as special-purpose machines, machine tools, gearboxes, and cooling machines.

◆ Dimensional Data & Technical Data

Model	Applicable Rotational Speed (min ⁻¹)	Discharge Volume (L/min)	A (mm)	B (mm)	C (mm)	D Bore	Max. Pressure	Suitable Viscosity	Suitable Temp. Range	N.W. (g)
CYP-10A	1420 - 1720	1.1 - 1.4	60.5	41	12	PT1/8	5 kgf/cm ²	32-68 cSt@40°C	0-90°C	616
CYP-11A-1	1420 - 1720	2.2 - 2.7	64.5	45	12	PT1/8				665
CYP-11A-2	1420 - 1720	2.2 - 2.7	64.5	45	12	PT1/4				664
CYP-12A	1420 - 1720	3.7 - 4.5	70.5	51	12	PT1/4				751
CYP-12L	450 - 1200	1.1 - 3.0	62.5	43	11	PT1/4				650
CYP-13A	1420 - 1720	6.5 - 7.9	82.5	63	16	PT3/8				924

※ If you need to add an adjustable pressure valve to the rotary oil pump, please add AV after the model number when you place an order. For example, CYP-11A-1-AV stands for one set of CYP-11A-1 assembled with CYP-AV.

※ After adding the adjustable pressure valve, the net weight increases by 110g.

Reversible Oil Pump (Clockwise and Anticlockwise)

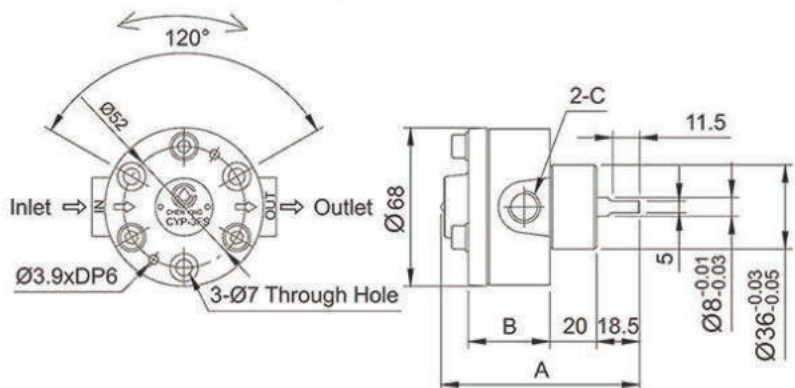

◆ Features

1. The direction of the inlet and outlet is fixed; the rotating shaft can rotate either clockwise or anticlockwise.
2. It is only suitable for assembling with gearboxes, not with motors.

◆ Dimensional Data & Technical Data

Model	Discharge Volume (L/min)		A (mm)	B (mm)	C Bore	Max. Pressure	Suitable Viscosity	Suitable Temp. Range	N.W. (g)
	1420min ⁻¹	1720min ⁻¹							
CYP-1FS	1.7	2.0	85	35	PT1/4	5 kgf/cm ²	32-68 cSt@40°C	0-90°C	1000
CYP-2FS	2.7	3.2	89	39					1100
CYP-3FS	3.7	4.5	93	43					1200

Heavy Oil Pump



CYP-204 Heavy Oil Pump



CYP-204-HA Heavy Oil Pump with Adjustable Pressure Valve

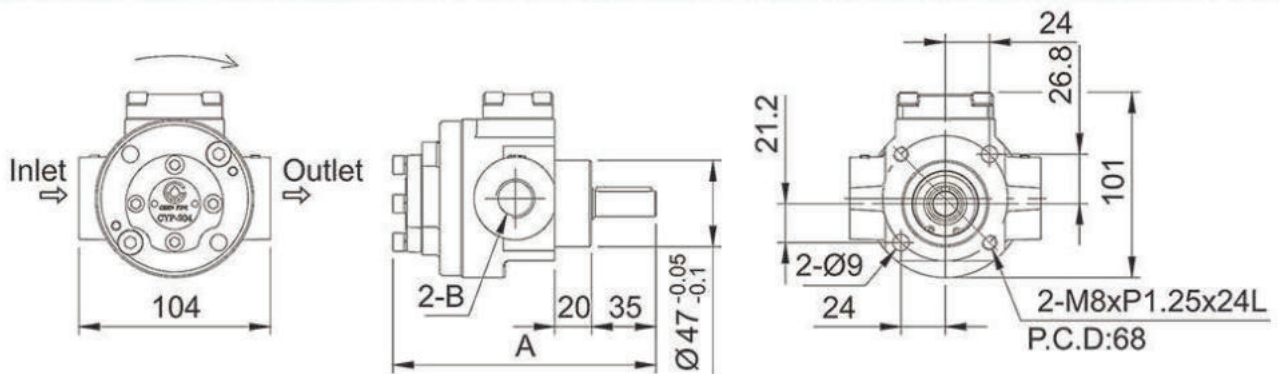

Dimensional Drawing of Heavy Oil Pump

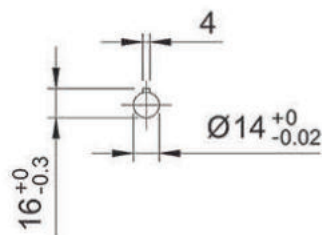

Shaft Size of CYP-204, 206, 208, 210, 212

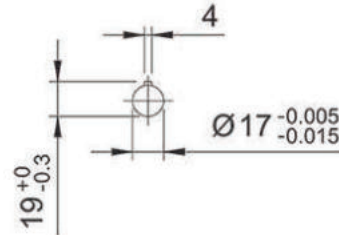

Shaft Size of CYP-216, 220

◆ Features

1. The discharge volume and the maximum pressure are much higher than the rotary oil pump.
2. Recommend adding a CYP-HA adjustable pressure valve to a heavy oil pump. The suitable range of pressure adjustment is 0 to 10kgf/cm². The proper operating pressure of the heavy oil pump should be under 10kgf/cm² to prevent damage due to high pressure.
3. Recommend working with a 1/2HP and above motor for lubricating and cooling purposes. It can be applied widely to various industrial machines, such as machine tools, screw machines, special-purpose machines, gearboxes, and medium to large machines.
4. If you need the heavy oil pump to be assembled with a PMO-0 motor, please refer to P.103 and provide us with the order code.

◆ Dimensional Data & Technical Data

Model	Discharge Volume (L/min)		A (mm)	B Bore	Applicable Rotational Speed (min ⁻¹)	Max. Pressure (kgf/cm ²)	Suitable Viscosity	N.W. (kg)	Suitable PMO-0 Motors (Minimum Horsepower)	
	1420min ⁻¹	1720min ⁻¹							W/CYP-HA	W/O CYP-HA
CYP-204	7.5	9.0	143	PT1/2	450 – 2000	20	32-220 cSt@40°C	3.2	1/2 HP	1 HP
CYP-206	11.3	13.5	148	PT3/4				3.3	1/2 HP	1 HP
CYP-208	15.3	18.5	153	PT3/4				3.5	1/2 HP	1 HP
CYP-210	19.0	23.0	158	PT3/4				3.7	1/2 HP	2 HP
CYP-212-1	21.9	26.5	163	PT3/4				3.9	1 HP	2 HP
CYP-212-2	21.9	26.5	163	PT1				3.9	1 HP	2 HP
CYP-216	29.3	35.5	173	PT1				4.3	1 HP	2 HP
CYP-220	34.3	41.5	183	PT1				4.6	2 HP	--

※ If you need to add an adjustable pressure valve to a heavy oil pump, please add HA after the model number when you place an order. For example, CYP-216-HA stands for one set of CYP-216 assembled with CYP-HA.

※ After adding the adjustable pressure valve, the net weight increases by 322g.

※ Heavy oil pump can add a holder on request. The fixed hole distance is 84x38mm, and the height is 134mm.

Steel Plate Frame Horizontal Motor

PMO-0

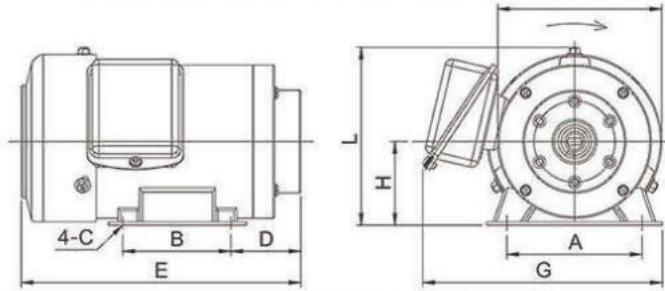

HP	A (mm)	B (mm)	C (mm)	D (mm)	E (mm)	F (mm)	G (mm)	H (mm)	L (mm)	N.W. (kg)
1/8	70	60	∅7	51.0	181	100.7	152	56	115	5.0
1/4	100	80	∅8	51.5	207	121.3	177	62	132	6.5

Cast Iron Frame Horizontal Motor

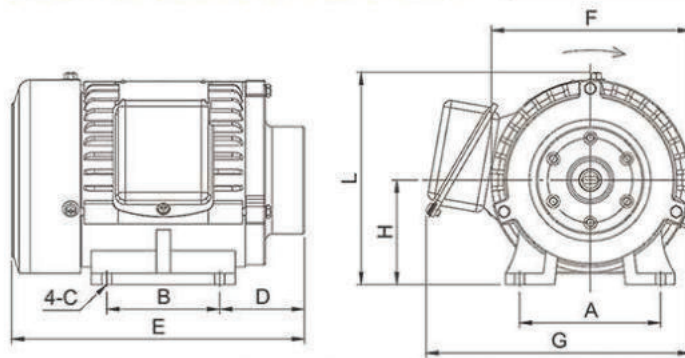

HP	A (mm)	B (mm)	C (mm)	D (mm)	E (mm)	F (mm)	G (mm)	H (mm)	L (mm)	N.W. (kg)
1/4	100	80	∅7	60.0	207.5	142	187.0	74	150.0	8.8
1/2	125	100	∅10	68.0	247.5	175	225.5	80	167.5	13.0
1	125	100	∅10	75.5	262.5	175	225.5	80	168.0	15.0
2	140	125	∅12	72.5	284.0	196	251.0	90	188.0	21.0

Cast Iron Frame Vertical Motor

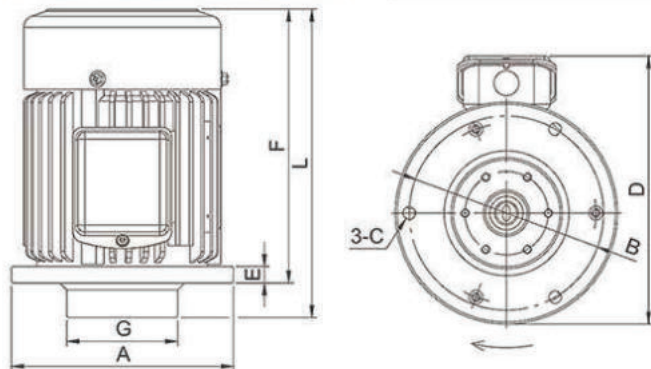

HP	A (mm)	B (mm)	C (mm)	D (mm)	E (mm)	F (mm)	G (mm)	L (mm)	N.W. (kg)
1/4	∅160	∅140	∅9	193	12	190	∅80	215	10.0

Order Code

PMO-0 — 02 — D — 1 — 2

Motor

HP
01 1/8 HP
02 1/4 HP
04 1/2 HP
08 1 HP
16 2 HP

Voltage	
A 1∅110V	G 3∅230/460V
C 1∅220V	H 3∅240/480V
D 3∅220/380V	M 3∅220V
E 3∅220/440V	N 3∅380V
F 3∅208/415V	X Special Voltage

Type	
1	Vertical Type (For 1/4HP Cast Iron Frame Only)
3	Horizontal Type

Frame	
1	Steel Plate (For 1/8HP, 1/4HP)
2	Cast Iron (For 1/4HP, 1/2HP, 1HP, 2HP)

※ A standard dual-voltage motor is connected for low voltage. Please specify if you need it to be connected to high voltage when placing an order.

1/4HP Motor with Rotary Oil Pump



CYP-11A-2-0-1-D



CYP-11A-2-0-2-D

◆ Order Code

CYP-11A-2

0

1

D

Rotary Oil Pump Model No.	
CYP-10A	
CYP-11A-1	
CYP-11A-2	
CYP-12A	
CYP-12L	
CYP-13A	

Adjustable Pressure Valve CYP-AV	
0	W/O CYP-AV
1	W/CYP-AV

1/4HP Motor Type	
1	Steel Plate Frame Horizontal Motor
2	Cast Iron Frame Horizontal Motor
3	Cast Iron Frame Vertical Motor

Voltage			
A	1Ø110V	G	3Ø230/460V
C	1Ø220V	H	3Ø240/480V
D	3Ø220/380V	M	3Ø220V
E	3Ø220/440V	N	3Ø380V
F	3Ø208/415V	X	Special Voltage

1/2HP and above Cast Iron Frame Horizontal Motor with Heavy Oil Pump



CYP-204-1-04-D



CYP-208-1-08-D-Y

◆ Order Code

CYP-204

1

04

D

※

Rotary Oil Pump Model No.	
CYP-204	
CYP-206	
CYP-208	
CYP-210	
CYP-212-1	
CYP-212-2	
CYP-216	
CYP-220	

Adjustable Pressure Valve CYP-HA	
0	W/O CYP-HA
1	W/CYP-HA

Cast Iron Frame Horizontal Motor	
04	1/2 HP
08	1 HP
16	2 HP

Voltage	
A	1Ø110V
C	1Ø220V
D	3Ø220/380V
E	3Ø220/440V
F	3Ø208/415V
G	3Ø230/460V
H	3Ø240/480V
M	3Ø220V
N	3Ø380V
X	Special Voltage

Special Request	
M	Change to TECO Motor, add a Coupling, Mounting Base, and Cover (For 1HP Only)
Y	Shaft Size Ø19, add a Coupling, Mounting Base, and Cover (For 1HP Only)

※ A standard dual-voltage motor is connected for low voltage. Please specify if you need it to be connected to high voltage when placing an order.

※ Recommend adding an adjustable pressure valve to prolong the lifetime of the motor and oil pump.

Steel Plate Frame Horizontal Motor with Connector

PMO-2

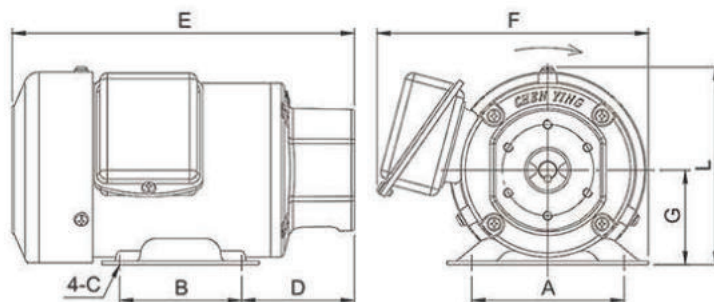

HP	A (mm)	B (mm)	C (mm)	D (mm)	E (mm)	F (mm)	G (mm)	L (mm)	N.W. (kg)
1/4	100	80	∅8	74.0	224.5	178	62	130	6.5

Steel Plate Frame Vertical Motor with Connector

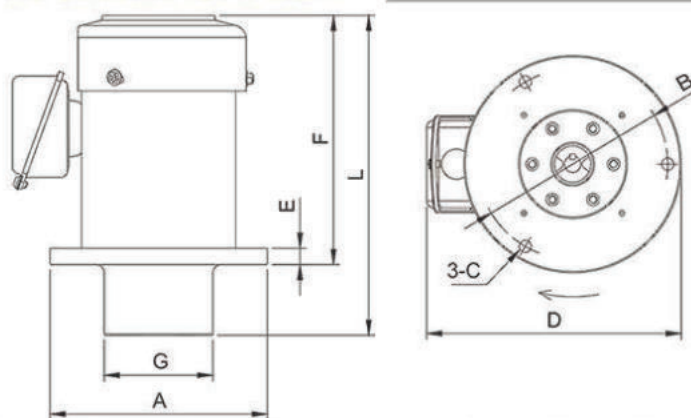

HP	A (mm)	B (mm)	C (mm)	D (mm)	E (mm)	F (mm)	G (mm)	L (mm)	N.W. (kg)
1/4	∅160	∅140	∅9	188.0	11	184	∅80	237	7.9

Order Code

PMO-2-02 — D — 3 — * — AV

Motor with Connector

HP
02 | 1/4 HP

Voltage	
A	1∅110V
C	1∅220V
D	3∅220/380V
E	3∅220/440V
F	3∅208/415V
G	3∅230/460V
H	3∅240/480V
M	3∅220V
N	3∅380V
X	Special Voltage

Type	
1	Vertical
3	Horizontal

Special Request (Add Rotary Oil Pump)	
10A	W/CYP-10A
11A-1	W/CYP-11A-1
11A-2	W/CYP-11A-2
12A	W/CYP-12A
12L	W/CYP-12L
13A	W/CYP-13A

Adding an Adjustable Pressure Valve

Optional



PMO-2-02-D-3-12A



PMO-2-02-D-3-12A-AV

- * A standard dual-voltage motor is connected for low voltage. Please specify if you need it to be connected to high voltage when placing an order.
- * Recommend adding an adjustable pressure valve to prolong the lifetime of the motor and oil pump.

Adjustable Pressure Valve



CYP-AV



CYP-HA

Model	Pressure Adjustment Range (kgf/cm ²)	Suitable Oil Pump	N.W. (g)
CYP-AV	0 - 5	Rotary Oil Pump	352
CYP-HA	0 - 10	Heavy Oil Pump	565

Electromagnetic Pump

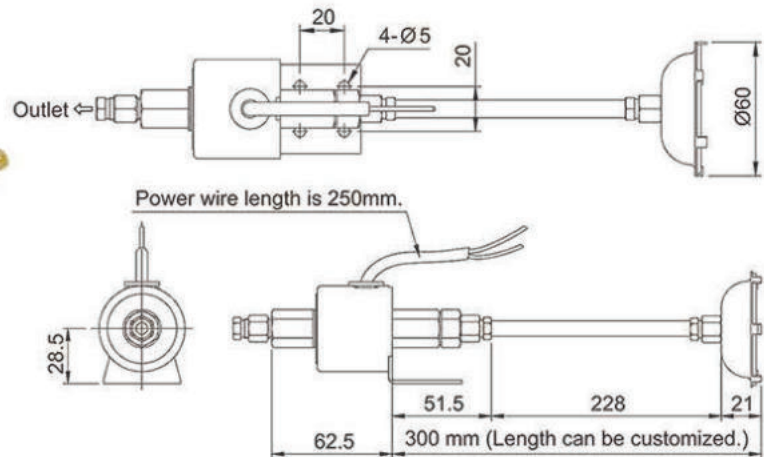

◆ Features

1. Electromagnetic pump operates according to the principle of electromagnetic with low power consumption.
2. Electromagnetic pump is compact and suitable for limited workspace.
3. Recommend applying electromagnetic pumps to small-size machines that require continuous lubrication and cooling, such as lathes, milling machines, grinding machines, and press machines.
4. The standard length of the pipe is 300mm, but it can be customized upon request.
5. The pipe's length and the lubricant's viscosity affect the discharge volume. The shorter the pipe length or the thinner the lubricant, the higher the discharge volume.
6. The higher the temperature, the lower the operating pressure.

◆ Technical Data

Model	Function	Power	Voltage	Discharge Volume	Outlet Bore	Operating Pressure	Suction Power	Max. Temp. Endurance	Suitable Viscosity	N.W. (g)
EL-1	Volume Fixed	25W	110V or 220V	300 cc/min	Ø4 or Ø6	0.8 - 1.2 kgf/cm ²	30±5 cmHg	85°C	32-68 cSt@40°C	400
EL-2	Volume Adjustable									450

◆ Order Code

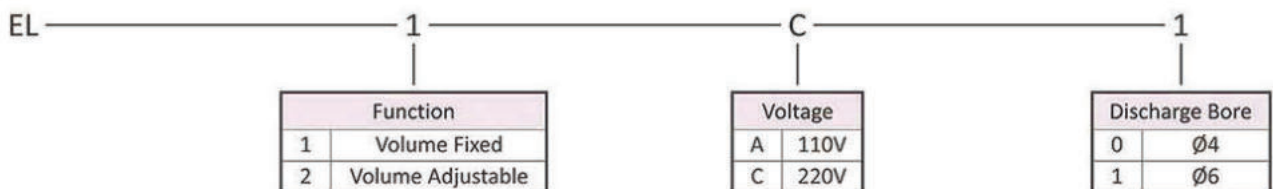

GA-25 Gear Pump with Motor

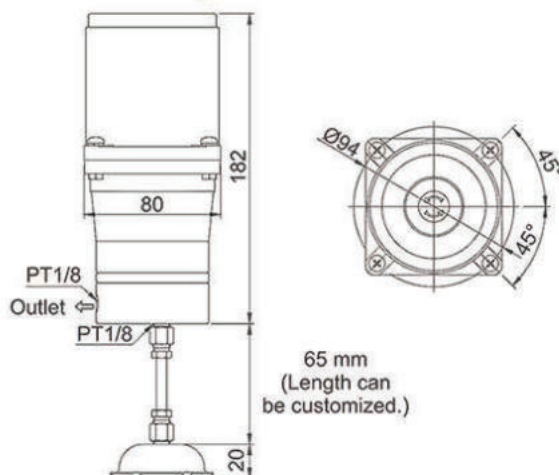

◆ Features

1. GA-25 is compact and suitable for limited workspace.
2. The gear pump of GA-25 is made of aluminum alloy and assembled with a 25W induction motor to provide stable output pressure, low operating noise, and long service life.
3. The standard length of the pipe is 65mm, but it can be customized upon request.

◆ Order Code

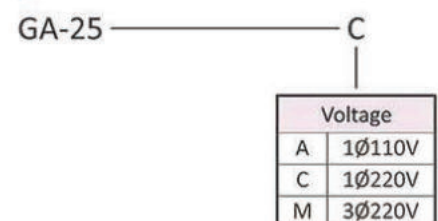

◆ Technical Data

Motor	Voltage	Ampere	Hertz	Max. Discharge Volume	Max. Pressure	Suitable Viscosity	N.W. (kg)
25W	1Ø110V	0.6A	50/60Hz Compatible	250 cc/min	12 Kg/cm ²	32-68 cSt@40°C	3
	1Ø220V	0.3A					
	3Ø220V	0.3A					

Compression Bushing

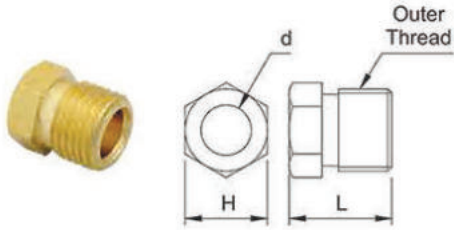

Model	Bore	d	L (mm)	H (mm)	Outer Thread	N.W. (g)
PA-4	Ø4	Ø4.1	12.0	8	M8xP1.0	3
PA-6	Ø6	Ø6.1	12.5	10	M10xP1.0	4
PA-8	Ø8	Ø8.1	14.0	14	M14xP1.5	9
PA-10	Ø10	Ø10.1	15.0	16	M16xP1.5	12
PA-12	Ø12	Ø12.1	16.0	19	M18xP1.5	16

One-Side-Tapered Compression Bushing

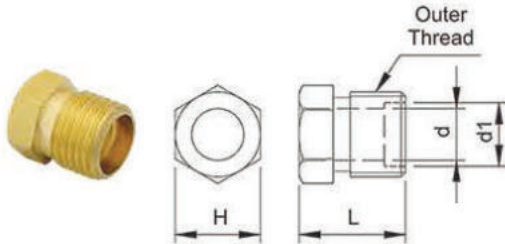

Model	Bore	d	d1	L (mm)	H (mm)	Outer Thread	N.W. (g)
PA104	Ø4	Ø4.1	Ø5.5	12.0	8	M8xP1.0	3.0
PA106	Ø6	Ø6.1	Ø7.5	12.5	10	M10xP1.0	4.0
PA108	Ø8	Ø8.1	Ø9.2	14.0	14	M14xP1.5	9.7

※ One-Side-Tapered Compression Bushing only works with One-Side-Tapered Compression Sleeve.

Compression Sleeve

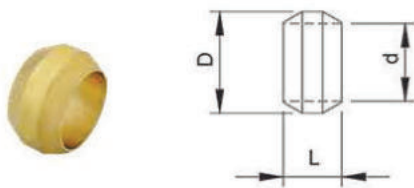

Model	Bore	d	D	L (mm)	N.W. (g)
PB-4	Ø4	Ø4.1	Ø6.0	4.6	0.3
PB-6	Ø6	Ø6.1	Ø8.0	4.6	0.6
PB-8	Ø8	Ø8.1	Ø11.0	7.0	2.0
PB-10	Ø10	Ø10.1	Ø13.5	8.0	3.0
PB-12	Ø12	Ø12.1	Ø16.0	9.0	4.0

One-Side-Tapered Compression Sleeve

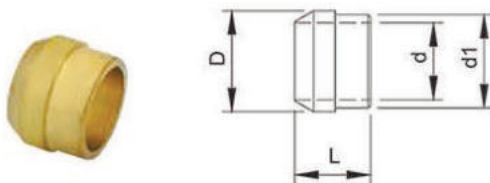

Model	Bore	d	d1	D	L (mm)	N.W. (g)
PB104	Ø4	Ø4.1	5.4	Ø6	5.5	0.4
PB106	Ø6	Ø6.1	7.4	Ø8	6.0	0.7
PB108	Ø8	Ø8.1	9.1	Ø10	7.0	1.1

Closure Plug

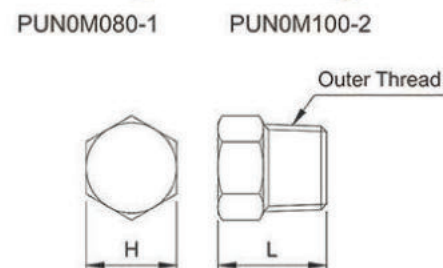

Model	Outer Thread	L (mm)	H (mm)	N.W. (g)
PG-004	M8xP1.0	12	8	4
PG-1	PT1/8	12	10	6
PUN0M080-1	M8xP1.0 (Central Bore Ø3, Long Type)	16	8	6
PUN0M100-2	M10xP1.0 (Central Bore Ø6)	16	10	8

Straight Adapter

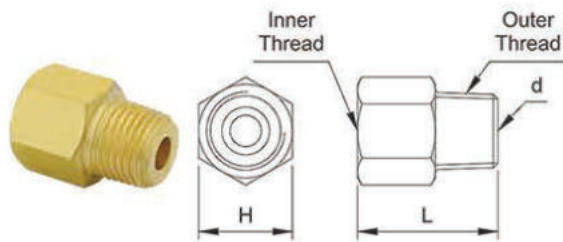

Standard Models								
Model	Bore	Inner Thread	Outer Thread	d	L (mm)	H (mm)	N.W. (g)	Set
PD-401	Ø4	M8xPT1.0	PT1/8	Ø3	18	10	8	*
PD-402			PT1/4	Ø3	18	14	17	*
PD-403			PT3/8	Ø3	18	17	28	*
PD-601	Ø6	M10xP1.0	PT1/8	Ø4	18	12	8	*
PD-602			PT1/4	Ø5	18	14	14	*
PD-603			PT3/8	Ø5	18	17	24	*
PD-801	Ø8	M14xP1.5	PT1/8	Ø5	26	17	22	*
PD-802			PT1/4	Ø6	26	17	26	*
PD-803			PT3/8	Ø7	26	17	30	*
PD-1002	Ø10	M16xP1.5	PT1/4	Ø7	30	19	33	*
PD-1003			PT3/8	Ø9	30	19	35	*
PD-1202	Ø12	M18xP1.5	PT1/4	Ø7	32	21	42	*
PD-1203			PT3/8	Ø9	34	21	46	*
Non-Standard Models								
Model	Bore	Inner Thread	Outer Thread	d	L (mm)	H (mm)	N.W. (g)	Set
PD-406	Ø4	M8xPT1.0	M6xP0.75	Ø2	20	10	6	*
PD-4061			M6xP1.0	Ø2	20	10	6	*
PD-408			M8xP1.0	Ø3	18	10	6	*
PD-410			M10xP1.0 (TAP)	Ø3	18	10	6	*
PD-606	Ø6	M10xP1.0	M6xP0.75	Ø2	18	12	8	*
PD-6061			M6xP1.0	Ø2	18	12	8	*
PD-608			M8xP1.0	Ø3	21	12	8	*
PD-610			M10xP1.0 (TAP)	Ø4	18	12	8	*
PD-101	-	PT1/8	PT1/8	-	18	12	9	--
PD-102	-		PT1/4	-	18	14	16	--
PD-202	-	PT1/4	PT1/4	-	18	16	14	--
PD-203	-		PT3/8	-	26	17	34	--

One-Way Flow Straight Adapter

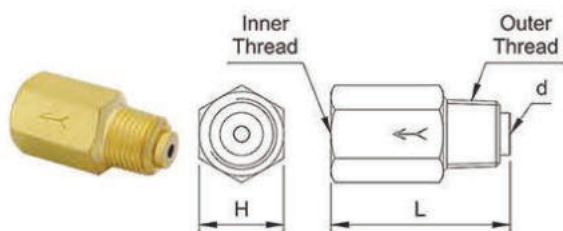

Model	Bore	Inner Thread	Outer Thread	d	L (mm)	H (mm)	N.W. (g)	Set
PD-4011	Ø4	M8xPT1.0	PT1/8	Ø2.2	24.5	10	11	*
PD-6011	Ø6	M10xP1.0			25.5	12	14	*

Reverse Flow Straight Adapter

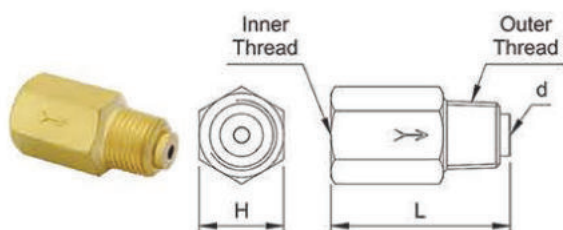

Model	Bore	Inner Thread	Outer Thread	d	L (mm)	H (mm)	N.W. (g)	Set
PD-4012	Ø4	M8xPT1.0	PT1/8	Ø2.2	24.5	10	11	*
PD-6012	Ø6	M10xP1.0			25.5	12	14	*

※ The model with an "*" mark can be assembled with compression bushing and compression sleeve as a set. If you need the model as a set, please specify when you place an order.

Quick Straight Coupling

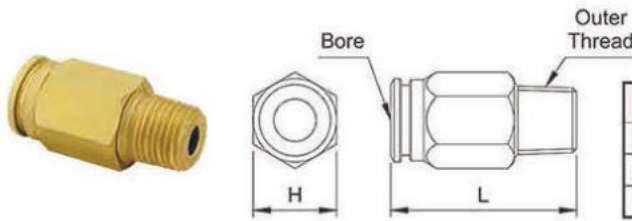

Model	Bore	Outer Thread	L (mm)	H (mm)	N.W. (g)
PD701A02	Ø4	PT1/8	10	22	9
PD702A02	Ø6	PT1/8	12	27	13
PD702V01	Ø6	M10xP1.0 (TAP)	12	27	13

◆ Features

1. Quick straight coupling is designed for replacing pipes efficiently.
2. Chen Ying Quick straight coupling has high pressure endurance of 60kgf/cm², which is higher than general quick couplings in the market that commonly only endure 15kgf/cm² of pressure.
3. Recommend using quick straight coupling with flexible pipes such as nylon 12 pipes and PE pipes.
4. Quick straight coupling is suitable for air, oil, and grease use. Incompatible lubricants may deteriorate the inner rubber.

◆ Instructions for Use

Connection		Disconnection	
	<ol style="list-style-type: none"> 1. Make sure the cutting edge of the pipe is smooth and flat. 		<ol style="list-style-type: none"> 1. Push down the top of the quick coupling with the thumb and index finger to loosen it from the pipe.
	<ol style="list-style-type: none"> 2. Insert the pipe into the quick coupling then you will hear two click sounds. 3. Pull the pipe to check if it is securely locked. 		<ol style="list-style-type: none"> 2. Use the other hand to push the pipe into the quick coupling gently. Then, rotate the pipe for approximately a 90-degree angle and simultaneously pull the pipe out.

Elbow Adapter



PH-400



PH-601

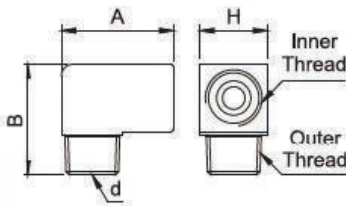

Standard Models									
Model	Bore	Inner Thread	Outer Thread	d	A (mm)	B (mm)	H (mm)	N.W. (g)	Set
PH-400	Ø4	M8xPT1.0	Ø5.7-6.2	Ø3	18	18	10	13	*
PH-401			PT1/8	Ø4	18	18	10	13	*
PH-402			PT1/4	Ø5	20	21	14	32	*
PH-601	Ø6	M10xP1.0	PT1/8	Ø4	20	20	12	20	*
PH-602			PT1/4	Ø5	20	21	14	29	*
PH-801	Ø8	M14xP1.5	PT1/8	Ø4	26	29	17	52	*
PH-802			PT1/4	Ø6	26	29	17	56	*
PH-803			PT3/8	Ø8	26	29	17	59	*
PH-1002	Ø10	M16xP1.5	PT1/4	Ø7	29	31	19	70	*
PH-1003			PT3/8	Ø8	29	31	19	76	*
PH-1202	Ø12	M18xP1.5	PT1/4	Ø7	33	34	21	91	*
PH-1203			PT3/8	Ø10	33	34	21	95	*
Non-Standard Models									
Model	Bore	Inner Thread	Outer Thread	d	A (mm)	B (mm)	H (mm)	N.W. (g)	Set
PH-406	Ø4	M8xPT1.0	M6xP0.75	Ø2	18	18	10	13	*
PH-4061			M6xP1.0	Ø2	18	18	10	13	*
PH-408			M8xP1.0	Ø3	18	18	10	14	*
PH-410			M10xP1.0 (TAP)	Ø2	20	20	12	24	*
PH-6061	Ø6	M10xP1.0	M6xP1.0	Ø2	20	20	12	20	*
PH-608			M8xP1.0	Ø3	20	20	12	20	*
PH-610			M10xP1.0 (TAP)	Ø4	20	20	12	22	*
PH-101	-	PT1/8	PT1/8	Ø4	20	20	12	17	--
PH00AV01	-	PT1/8	M10xP1.0 (TAP)	Ø4	20	20	12	21	--
PH-102	-	PT1/8	PT1/4	Ø5	20	21	14	30	--
PH-303	-	PT3/8	PT3/8	Ø10	33	34	21	91	--

One-Way Flow Elbow Adapter

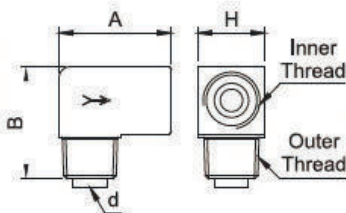

Model	Bore	Inner Thread	Outer Thread	d	A (mm)	B (mm)	H (mm)	N.W. (g)	Set
PH-4011	Ø4	M8xP1.0	PT1/8	Ø2.2	18	19.5	10	11	*
PH-6011	Ø6	M10xP1.0			20	21.5	12	14	*

Reverse Flow Elbow Adapter

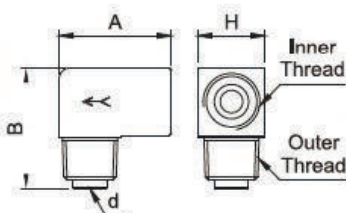

Model	Bore	Inner Thread	Outer Thread	d	A (mm)	B (mm)	H (mm)	N.W. (g)	Set
PH-4012	Ø4	M8xP1.0	PT1/8	Ø2.2	18	19.5	10	11	*
PH-6012	Ø6	M10xP1.0			20	21.5	12	14	*

※ The model with an "*" mark can be assembled with compression bushing and compression sleeve as a set. If you need the model as a set, please specify when you place an order.

Connect A/B

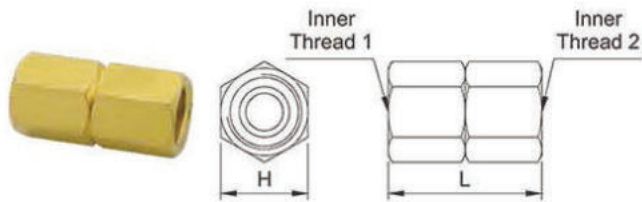

Connector A							
Model	Bore	Inner Thread 1	Inner Thread 2	H (mm)	L (mm)	N.W. (g)	Set
PM-4	∅4	M8xPT1.0		10	26	17	*
PM-6	∅6	M10xP1.0		12	26	12	*
PM-8	∅8	M14xP1.5		17	33	40	*
PM-10	∅10	M16xP1.5		19	37	51	*
PM-12	∅12	M18xP1.5		21	37	65	*
Connector B							
Model	Bore	Inner Thread 1	Inner Thread 2	H (mm)	L (mm)	N.W. (g)	Set
PN-4	∅4	M8xPT1.0	PT1/8	12	23	16	*
PN-6	∅6	M10xP1.0	PT1/8	12	23	12	*
PN-10	∅10	M16xP1.5	PT1/4	19	32	58	*

Connector

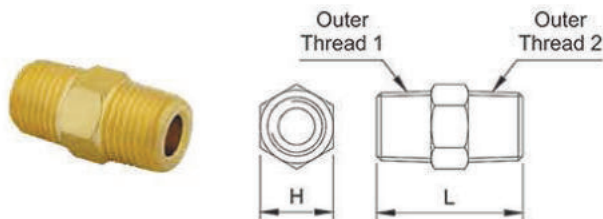

Model	Inner Thread 1	Inner Thread 2	H (mm)	L (mm)	N.W. (g)	Set
CN-101	PT1/8	PT1/8	10	21	8.0	--
RN-102		PT1/4	14	23	16.0	--
CN-202	PT1/4	PT1/4	14	25	10.0	--
RN-203		PT3/8	17	27	18.0	--
PROCP5	M8xP1.0	PT1/8	10	22	8.4	--
PROCPV-1		M10xP1.0	10	22	6.6	--
PTD10010	M10xP1.0	PT1/8	10	20	8.5	--
PTD10100		M10xP1.0	10	20	7.5	--

Swivel Straight Adapter

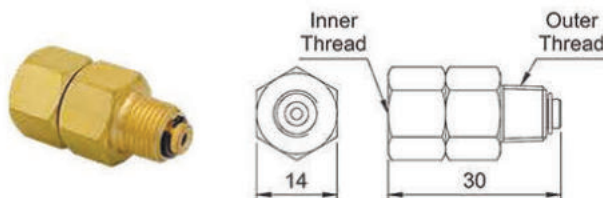

Model	Inner Thread	Outer Thread	N.W. (g)	Set
SS-101	PT1/8	PT1/8	26	--
SS-401	M8xP1.0	PT1/8	28	*

Plane Swivel Elbow Adapter A

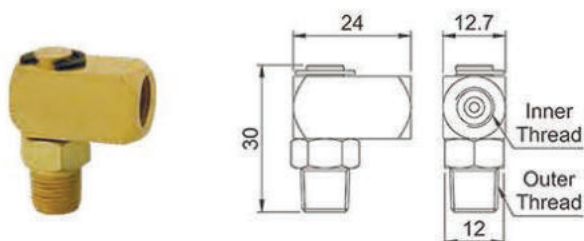

Model	Inner Thread	Outer Thread	N.W. (g)	Set
ES-401(A)	M8xP1.0	PT1/8	38	*
ES-601(A)	M10xP1.0	PT1/8	38	*

Plane Swivel Elbow Adapter B

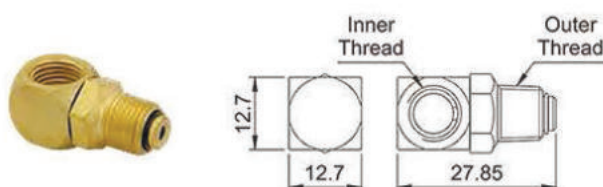

Model	Inner Thread	Outer Thread	N.W. (g)	Set
ES-101(B)	PT1/8	PT1/8	36	--

※ The model with an "*" mark can be assembled with compression bushing and compression sleeve as a set. If you need the model as a set, please specify when you place an order.

Compression Nut

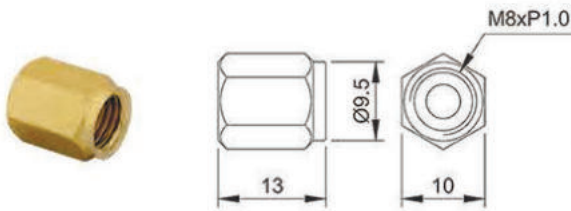

Model	Inner Thread	N.W. (g)	Set
PR-08	M8xP1.0	4	--

Elbow Connector

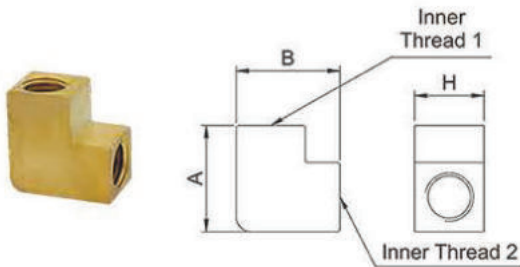

Model	Bore	d	Inner Thread 1	Inner Thread 2	A (mm)	B (mm)	H (mm)	N.W. (g)	Set
FEA-404	∅4	∅3	M8xP1.0	M8xP1.0	18	18	10	16.0	*
FEA-808	∅8	∅6	M14xP1.5	M14xP1.5	29	31	19	88.0	*
FEA-1002	∅10	∅8	M16xP1.5	PS1/4	29	31	19	81.5	*

3-Way Connector

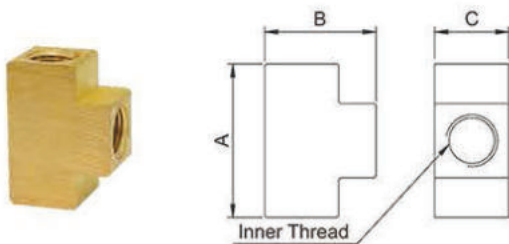

Model	Inner Thread	A (mm)	B (mm)	C (mm)	N.W. (g)	Set
PKD-01	PT1/8	29.0	21	14	34	--
PKD-02	PT1/4	28.5	23	18	47	--
PKD-03	PT3/8	40.0	30	21	86	--

4-Way Connector

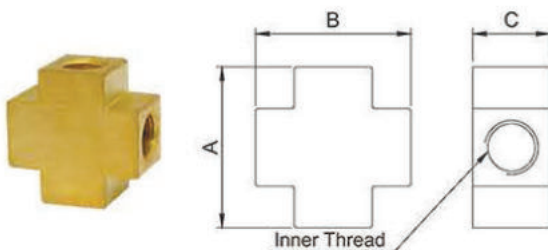

Model	Inner Thread	A (mm)	B (mm)	C (mm)	N.W. (g)	Set
PJD-01	PT1/8	28.5	28.5	14	38	--
PJD-02	PT1/4	30.0	30.0	18	58	--
PJD-03	PT3/8	40.0	40.0	21	105	--

Plane Elbow Adapter

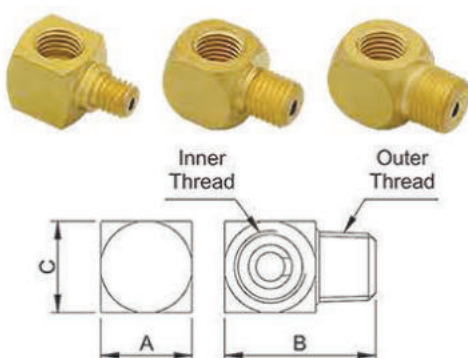

Model	Inner Thread	Outer Thread	A (mm)	B (mm)	C (mm)	N.W. (g)	Set
PI-401	M8xP1.0	PT1/8	12.7	21	12.7	13	*
PI-402		PT1/4	14.0	24	14.0	22	*
PI-408		M8xP1.0	12.7	21	12.7	12	*
PI-4061		M6xP1.0	12.0	20	12.0	14	*
PI-601	M10xP1.0	PT1/8	12.7	21	12.7	13	*
PI-101	PT1/8	PT1/8	12.7	21	12.7	17	--
PI-1011		PT1/8	12.7	30	12.7	20	--
PI-102		PT1/4	14.0	24	14.0	18	--
PI-106		M6xP0.75	12.0	20	12.0	10	--
PI-1061		M6xP1.0	12.0	20	12.0	10	--

※ The model with an "*" mark can be assembled with compression bushing and compression sleeve as a set. If you need the model as a set, please specify when you place an order.

Transparent Straight Adapter

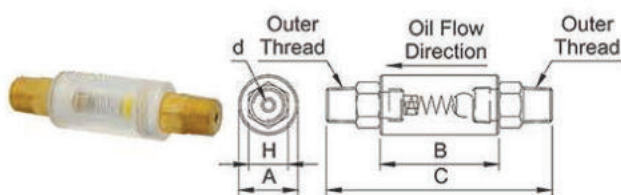

Model	d	Outer Thread	A	B (mm)	C (mm)	H (mm)	N.W. (g)	Set
DV-5	Ø2.5	PT1/8xPT1/8	15	30	57	10	25	--
DV-10	Ø5.0	PT1/4xPT1/4	22	50	90	17	85	--

Tube Insert

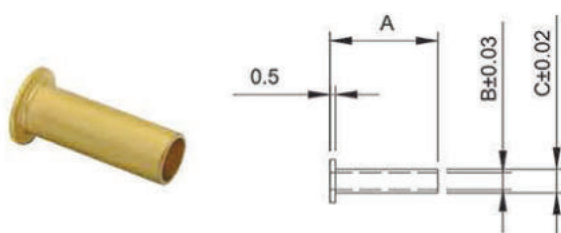

Model	Bore	A (mm)	B	C	N.W. (g)	Set
PO-403	Ø4	10	Ø1.50	Ø2.05	0.16	--
PO-4			Ø1.60	Ø2.10	0.16	--
PO-405			Ø1.60	Ø2.20	0.16	--
PO-401			Ø1.70	Ø2.50	0.25	--
PO-601	Ø6	12	Ø3.34	Ø3.95	0.43	--
PO-8	Ø8	15	Ø5.40	Ø6.00	0.73	--

Connector

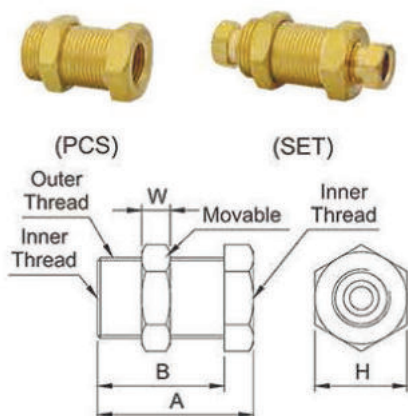

Model	Bore	Inner Thread	Outer Thread	A (mm)	B (mm)	H (mm)	W (mm)	N.W. (g)	Set
PM-104	Ø4	M8xP1.0	M12xP1.0	27	22	14	5	21	*
PM-106	Ø6	M10xP1.0	M14xP1.0	27	22	16	5	26	*
PM-108	Ø8	M14xP1.5	M18xP1.5	33	26	21	7	49	*
PM-110	Ø10	M16xP1.5	M20xP1.5	36	28	23	8	62	*

2-Way Junction A/B

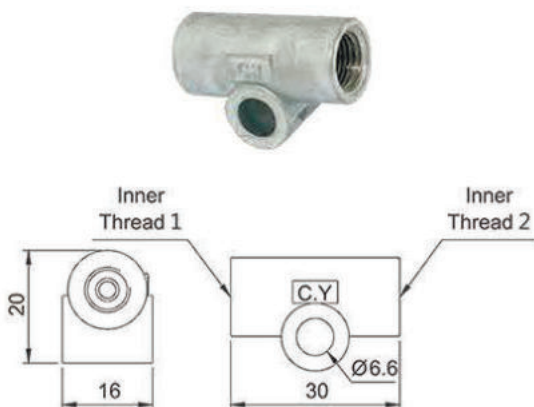

2-Way Junction A					
Model	Bore	Inner Thread 1	Inner Thread 2	N.W. (g)	Set
JD-4	Ø4	M8xP1.0		27	*
JD-6	Ø6	M10xP1.0		23	*
2-Way Junction B					
Model	Bore	Inner Thread 1	Inner Thread 2	N.W. (g)	Set
JD-601	Ø6	M10xP1.0	PT1/8	22	*
JD-406	Ø6xØ4	M10xP1.0	M8xP1.0	25	*

※ The model with an "*" mark can be assembled with compression bushing and compression sleeve as a set. If you need the model as a set, please specify when you place an order.

3-Way Junction

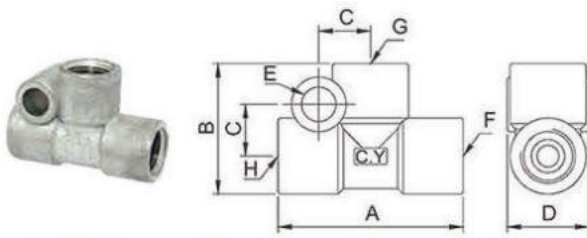

Model	Bore	Inner Thread	A (mm)	B (mm)	C (mm)	D (mm)	E	N.W. (g)	Set
PKD-4	∅4	M8xP1.0	29	19.4	8.5	12	∅6.3	16	*
PKD-6	∅6	M10xP1.0	34	24.0	9.5	15	∅6.3	32	*
PKD-8	∅8	M14xP1.5	42	31.0	14.5	19	∅6.8	64	*

※ If you need us to assemble other adapters to the 3-way junction for you, please use F, G, H in the drawing to indicate the position.

4-Way Junction

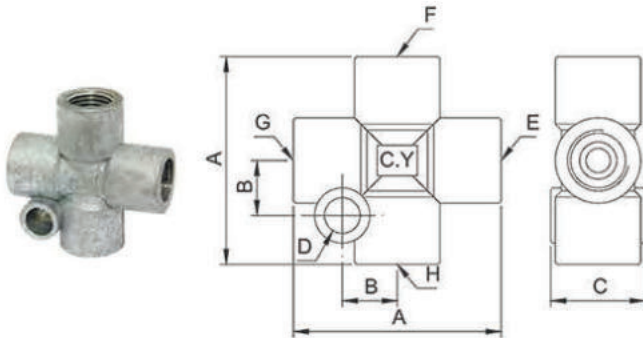

Model	Bore	Inner Thread	A (mm)	B (mm)	C (mm)	D	N.W. (g)	Set
PJD-4	∅4	M8xP1.0	30.0	8	11.0	∅5.3	23	*
PJD-6	∅6	M10xP1.0	34.0	9	15.5	∅5.8	33	*
PJD-8	∅8	M14xP1.5	41.5	12	22.0	∅6.8	94	*

※ If you need us to assemble other adapters to the 4-way junction for you, please use E, F, G, H in the drawing to indicate the position.

Vertical Junction

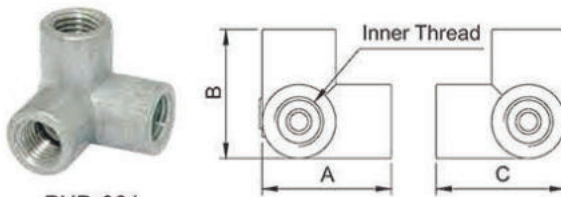

PHD-301

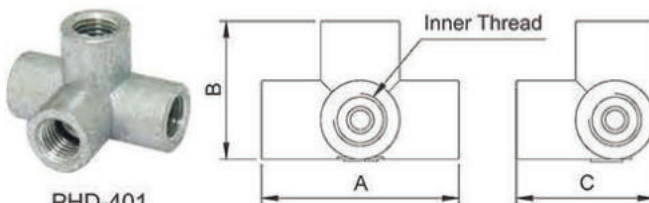

PHD-401

Model	Outlet No.	Bore	Inner Thread	A (mm)	B (mm)	C (mm)	N.W. (g)	Set
PHD-301	3	∅4	M8xP1.0	21	21	21	18	*
PHD-401	4			30	21	21	23	*
PHD-501	5			30	30	21	27	*

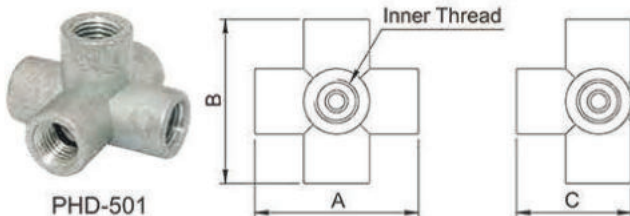

PHD-501

Swivel Fitting

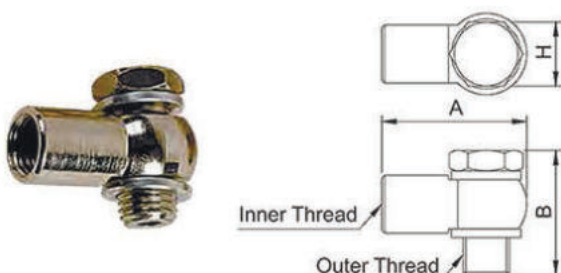

Model	Bore	Inner Thread	Outer Thread	A (mm)	B (mm)	H (mm)	N.W. (g)	Set
SI300400 (SET)	∅4	M8xP1.0		25	20	11.0	17	--
SI300600 (SET)	∅6	M10xP1.0		30	25	12.7	33	--

※ The model with an "*" mark can be assembled with compression bushing and compression sleeve as a set. If you need the model as a set, please specify when you place an order.

Grease Nipple

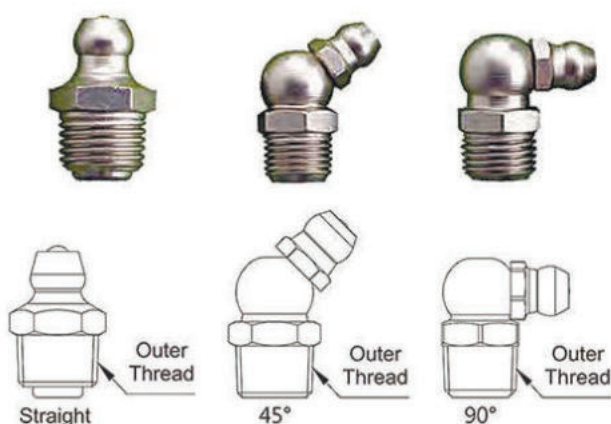

Model	Outer Thread	Angle	N.W.(g)
PJ000600	M6xP1.0	Straight	2.3
PJ000645		45°	6.0
PJ000690		90°	6.0
PJ000800	M8xP1.0	Straight	4.4
PJ000845		45°	7.7
PJ000890		90°	7.7
PJ010100	PT1/8	Straight	5.1
PJ010145		45°	8.2
PJ010190		90°	8.2
PJ010200	PT1/4	Straight	12.0
PJ010245		45°	18.0
PJ010290		90°	18.0

Horizontal Pressure Gauge



Model	Type	Max. Pressure (kgf/cm ²)	Size	Outer Thread	N.W. (g)
M06001	Dry	7	1-1/2"	PT1/8	60
M06003		15			
M06009		35			
M06029	Oil-Filled	14	1-1/2"	PT1/8	100
M06013		40			
M06030		70			
M06022		140			
M06034		200			

Vertical Pressure Gauge

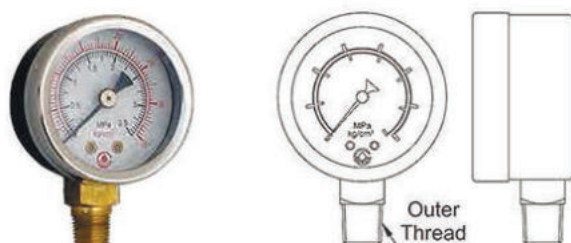

Model	Type	Max. Pressure (kgf/cm ²)	Size	Outer Thread	N.W. (g)
M06010	Dry	35	1-1/2"	PT1/8	60
M06023	Oil-Filled	10	2-1/2"	PT1/4	220
M06025		35			
M06027		100			

Oil Window

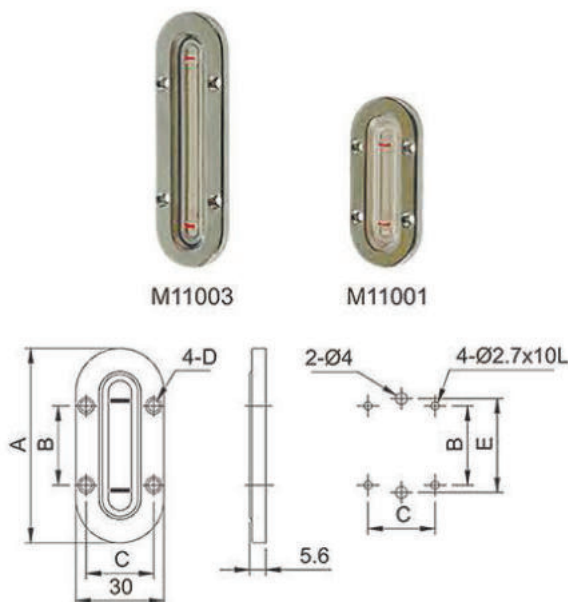

Model	A (mm)	B (mm)	C (mm)	D	E (mm)	N.W. (g)	Remarks
M11001 (SET)	66	27	22	Ø3.4	32	24	Small Oil Window (For CTA-8, CLA-6, and CLAB-6)
M11003 (SET)	98	45	23	Ø4.0	62	36	Big Oil Window (For CLA-8, CLAB-8, and Lubricators with Oil Tank Smaller than 12-Liter)

Brush



(PCS)

(SET)

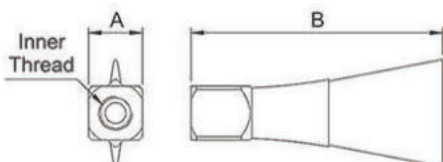

Model	Inner Thread	A (mm)	B (mm)	N.W. (g)	Set
M25006-1	Ø4 (M8xP1.0)	13	73	11.0	--
M25006-1S		13	73	15.0	*
M25006	Ø6 (M10xP1.0)	16	75	17.0	--
M25006S		16	75	21.5	*

※ The model with an "*" mark is assembled with compression bushing and compression sleeve as a set.

Oil Rotary Union

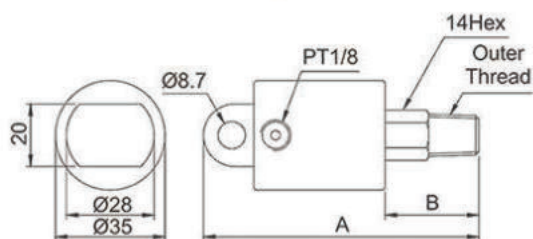

Model	Outer Thread	A (mm)	B (mm)	N.W. (g)
PWN-130	PT1/8	88	32	150
PWN-142		100	42	160
PWN-160		118	60	180
PWN-230	PT1/4	88	30	160
PWN-242		100	42	170
PWN-260		118	60	190

Air / Water Rotary Union

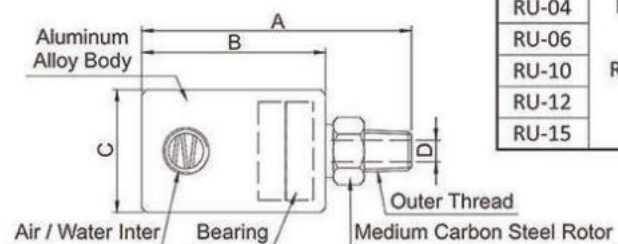

Model	Inner Thread	Inner Thread	Outer Thread	A (mm)	B (mm)	C	D	N.W. (g)		
RU-02	Left Thread or Right Thread		PT1/4	88	60	Ø40	Ø7	256		
RU-03			PT3/8	88	60	Ø40	Ø9	265		
RU-04			PT1/2	104	70	Ø50	Ø12	484		
RU-06			PT3/4	122	80	Ø60	Ø16	776		
RU-10			PT1	134	93	Ø70	Ø20	1144		
RU-12			PT1-1/4	160	110	Ø85	Ø28	1987		
RU-15			PT1-1/2		PT1-1/2	170	120	Ø93	Ø32	2593

◆ Features

- The bodies of air and water rotary unions are made of highly durable aluminum alloy, medium carbon steel rotors, and high-quality bearings to provide the best result.
- An air or water rotary union is one-way passage. Please follow the dimensional drawing to connect the air inlet or water inlet.
- Forbid to use any lubricant or cooling fluid.
- The max operating pressure for air rotary union is 10kgf/cm², and for water rotary union is 30kgf/cm².
- The suitable rotational speed is below 900min⁻¹. The rotational speed between 1000 to 2000 min⁻¹ is only available for rotary water unions.
- Air and water rotary unions are designed for continuous operation under either max operating pressure or rotational speed. If the working condition requires the rotary union to run simultaneously under max operating pressure and rotational speed, please specify when you place an order.

◆ Order Code

RU-02 ————— R ————— A ————— N ————— ※

Model				Inlet Thread		Medium		Rotational Speed		Special Request	
RU-02	RU-04	RU-10	RU-15	L	Left Thread	A	Air	N	900min ⁻¹	S	Designated Specification or Brand of Bearing
RU-03	RU-06	RU-12		R	Right Thread	W	Water	H	1000-2000min ⁻¹		

Float Ball / Float Switch



Galvanized Iron (SUS304) Float Ball



White Float Ball



Black Float Ball



Black Float Ball W/85mm Plastic Float Pillar



Black Float Ball W/85mm Alum. Float Pillar



Float Ball W/Float Pillar, Float Holder, and Wiring Connector

◆ Dimensional Drawings

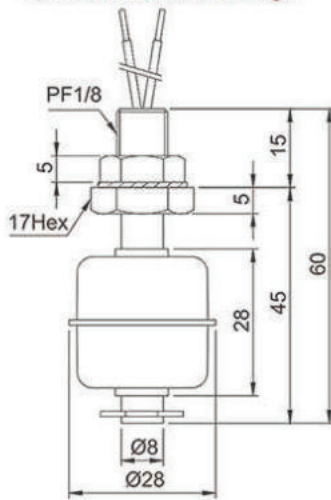

M21004 Galvanized Iron Float Ball

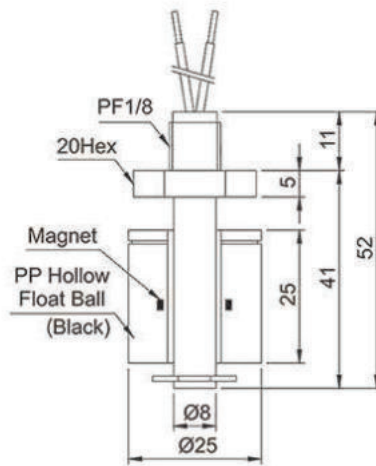

M21002 Black Float Ball

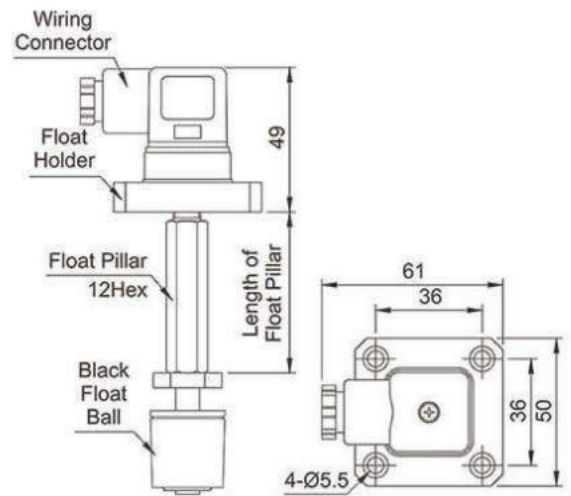

M21002 Black Float Ball W/Float Pillar, Float Holder, and Wiring Connector

◆ Features

- There are two contact types of float switches, NO contact and NC contact.
 - NO Contact:** The float switch sends a continuous signal when the oil level is high.
 - NC Contact:** The float switch sends a continuous signal when the oil level is low.
- The float ball's specific gravity should be less than the oil's; otherwise, it cannot float. (The specific gravity of water is 1, and the specific gravity of general lubricants is between 0.85 and 0.90.)
- When using oil with high viscosity, choose a large outer diameter of the float ball, so it can have greater buoyancy to overcome surface tension and have less misjudgment or malfunction when the level rises.
- A magnet inside the float ball induces the reed switch by its movement. If the oil contains iron filings, it will result in misjudgment. Please make sure the oil is clean for precise detection.

◆ Technical Data

Order Code	Model	Contact Type	Type	Float Ball Material	Outer Thread	Specific Gravity (SG)	Suitable Temp. (°C)	Max. Switching Current	Max. Carry Current	Max. Contact Capacity	N.W. (g)
DA01D004	M21004	NC	Galvanized Iron Float Ball	SUS304	PF1/8	0.7	-20 to 120	0.5A	1.0A	50W SPST	37
DA00D002	M21005	NO	White Float Ball	EVA/PE	M8xP1.25	1.0	-10 to 80	0.5A	1.0A	50W SPST	10
DA01D003	M21006	NC									
DA00D001	M21001	NO	Black Float Ball	PP	PF1/8	0.7	-20 to 80	0.5A	1.0A	50W SPST	12
DA01D001	M21002	NC									
DA10D001	S21005	NO	Black Float Ball W/85mm Plastic Float Pillar	PP	PF1/8	0.7	-20 to 80	0.5A	1.0A	50W SPST	68
DA11D001	S21006	NC									

※ S21005 and S21006 models: The standard length of the plastic float pillar is 85 mm for 2L and 3L oil tanks. Aluminum float pillars are available upon request. Please specify the length of the float pillar or the oil tank size while ordering.

※ S21005 and S21006 models can add float holders and wiring connectors upon request.

Pressure Switch

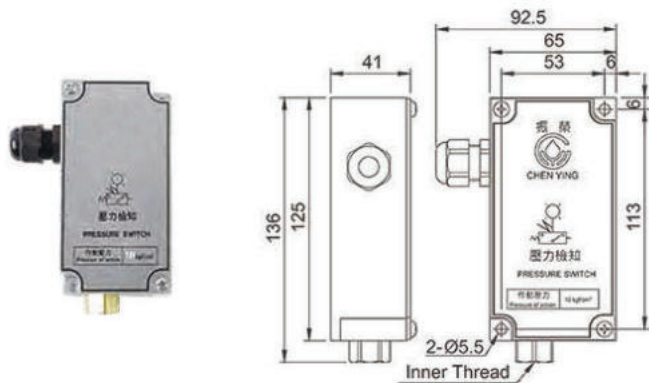

Model	Operating Pressure (kgf/cm ²)	Inner Thread	N.W. (g)
M21012	10	PT1/4	350
M21013	1		

Adjustable Pressure Switch

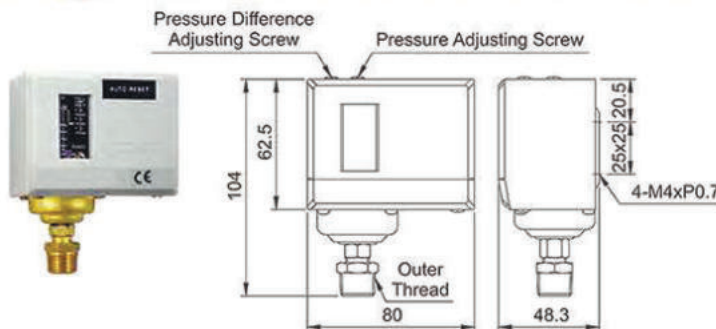

Model	Operating Pressure (kgf/cm ²)	Max. Pressure (kgf/cm ²)	Thread	N.W. (g)
M21039	0.5 to 3	11.0	7/16" - 20 (with an extra adapter, outer thread PT3/8)	420
M21040	0.5 to 6	16.5		
M21041	1 to 10	16.5		
M21042	5 to 30	30.0		

Socket Pressure Switch



20242 (50,000 Life Cycles)



PS8060 (100,000 Life Cycles)



DBS Series (1 Million Life Cycles)

◆ Features

- Socket pressure switches are usually added to the lubricator or the piping systems to detect pressure in centralized lubrication systems.
- There are two contact types of socket pressure switches, NO contact and NC contact.
 - **NO Contact:** The pressure switch sends a continuous signal when the pressure reaches the preset value.
 - **NC Contact:** The pressure switch sends a continuous signal when the pressure is below the preset value..
- A waterproof cover is a standard accessory for **DBS** series. **DB** series can add waterproof covers on request.

◆ Technical Data

Order Code	Model	Contact Type	Spec. (Kgf/cm ²)	Operating Pressure (kgf/cm ²)		Life Expectancy	Wiring Type	Suitable Temp. (°C)	Max. Current	Max. Voltage	Max. Pressure (Kgf/cm ²)	Outer Thread	N.W. (g)
				ON	OFF								
DB00A001	20142	NO	1 ± 0.2	1.2	0.8	50,000 Cycles	Push-on	-20 to 100	3.5A	DC12V	35	PT1/8	33
DB01A001	20143	NC	1 ± 0.2	0.8	1.2								
DB00A002	20163-5	NO	3.5 ± 0.5	4	2.5								
DB01A002	20163	NC	3.5 ± 0.5	2.5	4								
DB00A003	20140	NO	8 ± 1.0	8	6								
DB01A003	20141	NC	8 ± 1.0	6	8								
DB00A004	PS6080	NO	8 ± 0.3	8	6	100,000 Cycles	Push-on	-20 to 125	3.75A	AC240V	35	PT1/8	33
DB01A004	PS8060	NC	8 ± 0.3	6	8			-35 to 125					
DB01A006	PS1411	NC	14 ± 0.5	11	14			-35 to 125					
DBS0B008	--	NO	8 ± 0.5	--	--	1 Million Cycles	Screw	-10 to 100	4A	AC220V	35	PT1/8	65
DBS1B008	--	NC	8 ± 0.5	--	--								
DBS0B060	--	NO	60 ± 5%	--	--								
DBS1B060	--	NC	60 ± 5%	--	--								
C05D0018	M21025	DB Series Socket Pressure Switch Waterproof Cover (Black)											12

Filter

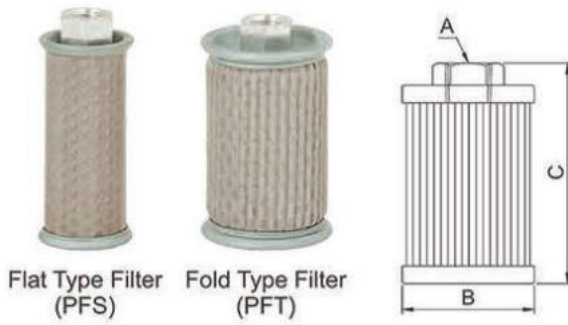

Type	Model	A	B	C (mm)	Mesh	N.W.(g)
Flat Type (PFS)	PFS0237059	PT1/4	Ø37	59	100	60
	PFS0260100		Ø60	100	80	130
	PFS0337100	PT3/8	Ø37	100	100	75
	PFS0360150		Ø60	150	100	153
Fold Type (PFT)	PFT0245080	PT1/4	Ø45	80	80	76
	PFT0245100		Ø45	100	80	88
	PFT0260100		Ø60	100	80	130
	PFT0260150		Ø60	150	80	167
	PFT0245060		Ø45	60	100	64
	PFT0260080		Ø60	80	80	117
	PFT0460100	PT1/2	Ø60	100	80	147
	PFT0460150		Ø60	150	80	186
	PFT0345060	PT3/8	Ø45	60	100	62
	PFT0360100		Ø60	100	100	127

Fixed Oil Filter (with Magnet Inside)

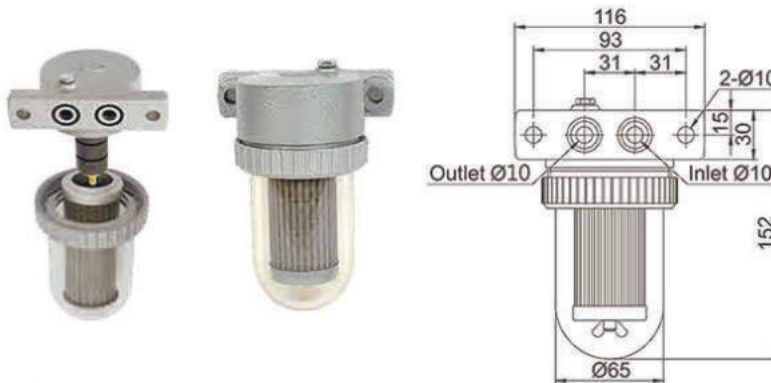

Model	Inlet	Outlet	Mesh	N.W.(g)
PFE20	Ø10	Ø10	100	1036

Oil Filter (with Magnet Inside)

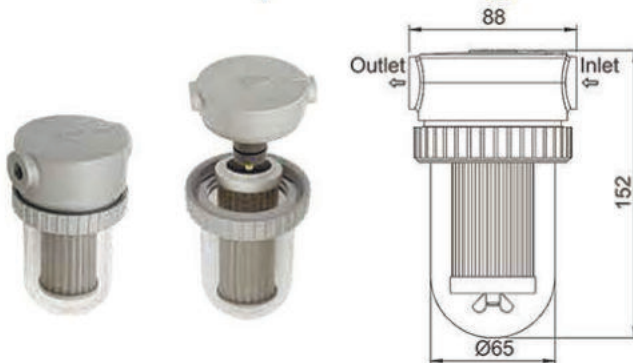

Model	Inlet	Outlet	Max. Pressure (kgf/cm ²)	Mesh	N.W.(g)
M21012	PT1/4	PT1/4	10	100	350
M21013	PT3/8	PT3/8			

Oil Filter

A-101-1 (Resin Oil Tank) A-101-2 / A-101-3 (Aluminum Oil Tank) A-101-2 A-101-3

Model	Inlet	Outlet	A (mm)	B (mm)	C (mm)	Max. Pressure (kgf/cm ²)	Mesh	N.W. (g)
A-101-1			106.5	83	51.5	10	40	260
A-101-2	PT1/8	PT1/8	123.5			30	400	440
A-101-3			123.5			30	40	440

Oil Auto Cleaner

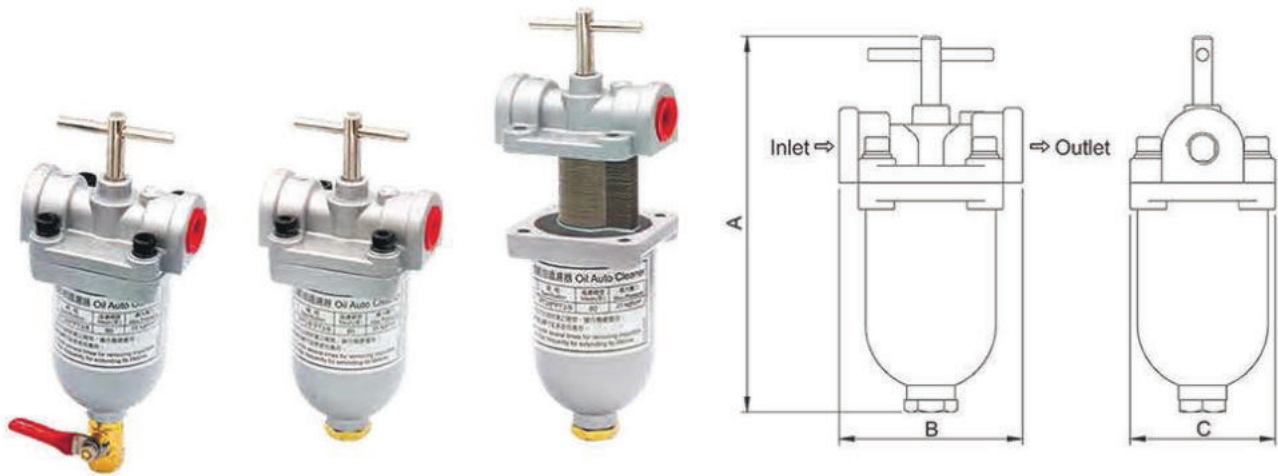

◆ Features

1. Oil auto cleaners are widely used in pipeline filtration of lubrication and hydraulic systems and other industries to maintain the performance of mechanical equipment.
2. The body of the oil auto cleaner is made of highly durable zinc alloy with a combination of large, small, and side stainless steel (SUS304) gaskets to form a filtration structure.
3. Oil auto cleaners can be cleaned at any time during the operation without shutting down the machine. It can save time for maintenance.
4. The suitable viscosity range is 10~220cSt@40°C. The operating temperature is 0~90°C.
5. Recommend working with Chen Ying's lubrication systems, which consist of rotary and heavy oil pumps with motors.

◆ Directions for Maintenance

1. To clean the oil auto cleaner during the machine operation time, release the bottom closure plug of the oil auto cleaner first. Then, turn the cross handle left and right several times to remove the impurities of the gaskets. When the impurities flow out with oil, tighten the closure plug to complete the cleaning process.
2. The bottom closure plug can be replaced with a ball valve for easy maintenance regularly, but the pressure resistance value will be reduced accordingly.

◆ Notice

1. The volume of lubricant would be less after flowing through the oil auto cleaner due to the filtration structure creating resistance when the lubricant enters.
2. The max flow rate of an oil auto cleaner is affected by various factors, such as lubricant, temperature, viscosity, flow rate, pressure, size of the passing area, mesh numbers, and bore size of inlets and outlets.

◆ Technical Data & Dimensional Data

Order Code	Model	Specification	Mesh	Hole Size (mm)	A (mm)	B (mm)	C (mm)	Max. Pressure (kgf/cm ²)	Closure Plug	N.W. (kg)
PFRAA08B1	A-102	PT1/4 x PT1/4	80	0.175	156.0	76	60	25	PS1/4	0.75
PFRAA10B1			100	0.147						
PFRAA08C1	A-103	PT3/8 x PT3/8	80	0.175	156.0	76	60	25	PS1/4	0.75
PFRAA10C1			100	0.147						
PFRAA08D1	A-104	PT1/2 x PT1/2	80	0.175	197.0	89	71	25	PS1/4	1.15
PFRAA10D1			100	0.147						
PFRSA08E1	A-105	PT3/4 x PT3/4	80	0.175	197.0	89	71	25	PS1/4	1.15
PFRSA10E1			100	0.147						
PFRAA08E1	A-106	PT3/4 x PT3/4	80	0.175	236.0	100	85	25	PS1/2	1.90
PFRAA10F1	A-110	PT1 x PT1	80	0.175	263.5	120	85	25	PS1/2	2.20

Magnetic Sensor Reed Switch (Standard Type / Large-Volume Type)

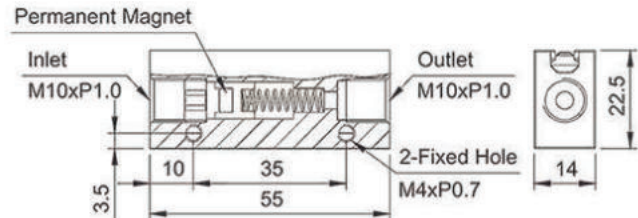
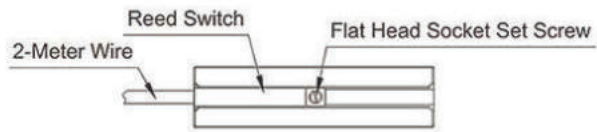

Standard Type Magnetic Sensor Reed Switch

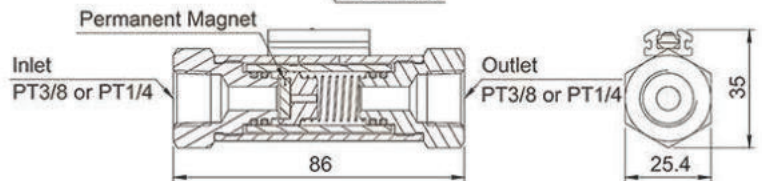
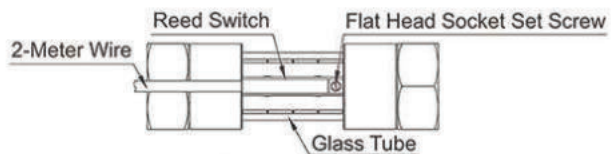

Large-Volume Type Magnetic Sensor Reed Switch

◆ Features

1. There are two contact types for magnetic sensor reed switches:
 - **NO Contact:** It sends a continuous signal when the oil flows through the pipes.
 - **NC Contact:** It sends a continuous signal when the oil does not flow through the pipes.
2. The movement of the permanent magnet activates the reed switch contacts without touching the oil in the pipe.
3. The user can place the reed switch in the required position. Its anti-vibration capability prevents sending false signals during vibration.
4. The installation angle of the magnetic sensor reed switch is not restricted, and the detection function is not affected by either vertical or horizontal positions.
5. A large-volume type magnetic sensor reed switch can work with a BS type transparent adjustable distributor's volume control base, extending to a maximum of six outlets optionally. It can adjust and monitor multi-pipe flow simultaneously.
6. Recommend working with oil filters with magnets inside that can filter iron filings from interfering with the permanent magnet of the sensor reed switch.
7. The standard type is suitable to work with resistance type or circulating type oil lubricators.
8. The large-volume type is suitable for the motor with a rotary oil pump (CYP-10A to CYP-13A) and circulating oil type lubricators.
9. The volume of oil would be less after flowing through the magnetic sensor reed switch due to it creates resistance when the oil enters.
10. The max flow rate and max pressure that the magnetic sensor reed switch can handle are affected by various factors, such as lubricant, temperature, viscosity, and spring force.

◆ Operating Sequence

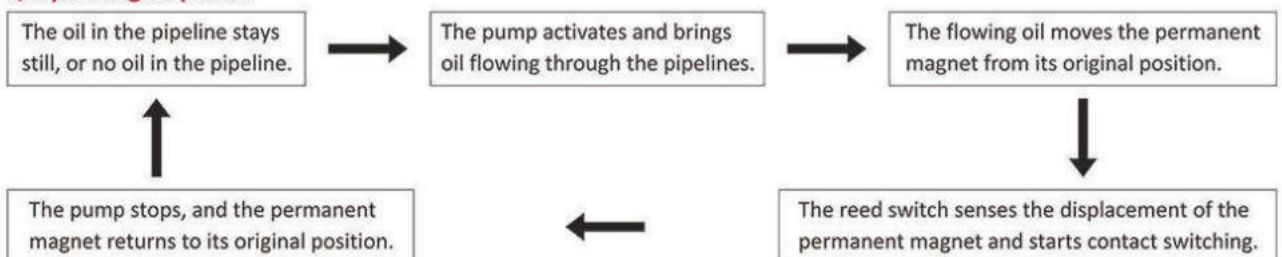

Magnetic Sensor Reed Switch (Standard Type / Large-Volume Type)

◆ Technical Data & Dimensional Data

Type	Standard Type Magnetic Sensor Reed Switch	Large-Volume Type Magnetic Sensor Reed Switch
Volume Detection Range	50-500 cc/min	1-5 L/min
Max Operating Pressure	15 kgf/cm ²	30kgf/cm ²
Max. Current Load (Load in series connection is required.)	0.5A	0.5A
Suitable Viscosity	Oil, 32-90cSt@40°C	Oil, 32-90cSt@40°C
N.W. (g)	90	118

◆ Order Code

DG — 10 ————— D005

Contact Type	Specification
10 NO Contact	D005 Standard Type, 0.5A, W/Light
11 NC Contact	DA02 Large-Volume Type, 0.5A, W/Light, PT1/4 Inlet & Outlet
	DB02 Large-Volume Type, 0.5A, W/Light, PT3/8 Inlet & Outlet

◆ Wiring Diagram

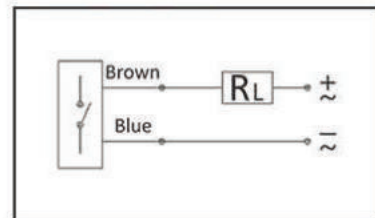

Pipes



Type	Order Code	Outer Dia.	Inner Dia.	Meter/Roll (MOQ: 1 Roll)	Packing Method	N.W. (kg/Roll)
Nylon Pipe (Nylon 6)	PPN0S001	∅3	∅1.5	100 M/Roll	Paper Roll	0.79
	PPN01001	∅4	∅2	100 M/Roll	Paper Roll	1.26
	PPN01002	∅4	∅2	200 M/Roll	Plastic Wrap	2.03
	PPN02001	∅6	∅4	100 M/Roll	Paper Roll	2.04
	PPN02002	∅6	∅4	100 M/Roll	Plastic Wrap	1.74
	PPN02005	∅6	∅3	100 M/Roll	Paper Roll	2.70
	PPN03001	∅8	∅6	100 M/Roll	Plastic Wrap	2.56
	PPN04001	∅10	∅7.5	100 M/Roll	Plastic Wrap	3.95
	PPN05001	∅12	∅9	100 M/Roll	Plastic Wrap	5.69
Nylon Pipe (Nylon 12)	PPN01003	∅4	∅2	100 M/Roll	Paper Roll	1.13
	PPN02003	∅6	∅4			1.81
Nylon Pipe (Made in Japan)	PPN01004	∅4	∅2.5	100 M/Roll	Plastic Wrap	1.10
	PPN02004	∅6	∅4			2.05
	PPN03002	∅8	∅6			2.86
PE Pipe	PPR01001	∅4	∅2	100 M/Roll	Plastic Wrap	0.86
	PPR02001	∅6	∅4			1.45
Aluminum Pipe	PPA01001	∅4	∅2	100 M/Roll	Plastic Wrap	2.40
	PPA02001	∅6	∅4	100 M/Roll		4.10
	PPA03001	∅8	∅6	30 M/Roll		6.00
Copper Pipe	PPC01001	∅4	∅3	50 M/Roll	Plastic Wrap	2.40
	PPC02001	∅6	∅5			4.50
	PPC02002	∅6	∅4.5			5.20
	PPC03001	∅8	∅6.5	30 M/Roll		4.30
	PPC04001	∅10	∅8			7.60
	PPC05001	∅12	∅10			9.30

Flexible Hose

Model	Bore	Inner Diameter	Outer Diameter	A (mm)	Min. Length	Max. Operating Pressure	Suitable Lubricant
PPST00	Ø4	Ø3.2-3.5	Ø7.6-7.9	21	100mm	40 kgf/cm ²	Oil
	Ø6	Ø4.2-4.5	Ø9.2-9.5				

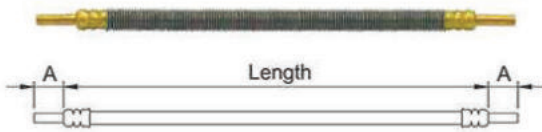

Order Code

PPST00 — 4 — 0100 — ×

Bore		Length		Special Request	
4	Ø4	0100	100mm	S	Add Compression Bushings and Sleeves to Both Ends
		to			
6	Ø6	9000	9000mm		

Flexible Hose Spring (For Guarding PPST00 Flexible Hose)



Model	Suitable PPST00 Bore	Spring Inner Dia.	Spring Outer Dia.	Standard Length	N.W. (g)
PPST20	Ø4	Ø8.7	Ø10.3	2000mm	158.6
	Ø6	Ø10.1	Ø11.9		208.4

Order Code

PPST20 — 4 — 2000

PPST00 Bore		Length	
4	Ø4	2000	2000mm
6	Ø6		

High-Pressure Flexible Hose

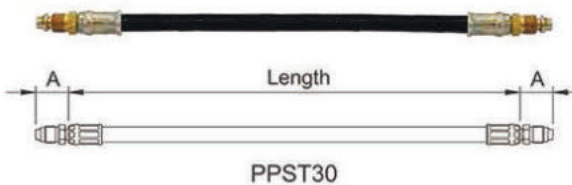

Model	Inner Diameter	Bore	A (mm)	Min. Length	Max. Operating Pressure	Suitable Lubricant
PPST30	1/8"	Ø4	20.5	150mm	300 kgf/cm ²	Grease
		Ø6	21.0			
PPST50	1/4"	Ø6	30.3			
		Ø8	30.3			

Order Code

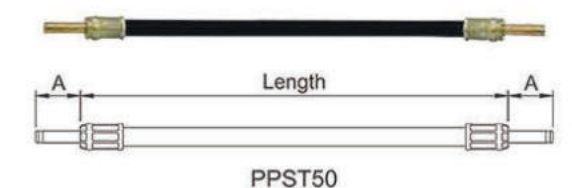

PPST — 30 — 4 — 0150

Inner Diameter		Bore		Length	
30	1/8"	4	Ø4 (PPST30 Only)	0150	150mm
50	1/4"	6	Ø6	to	
		8	Ø8 (PPST50 Only)	9000	9000mm

Flexible Metallic Hose

Model	Bore	A (mm)	Min. Length	Max. Operating Pressure	Suitable Lubricant
PPST40	Ø4 or Ø6	19	100mm	70 kgf/cm ²	Oil or Grease

Order Code



PPST40 — 4 — 0100

Bore		Length	
4	Ø4	0100	100mm
		to	
6	Ø6	9000	9000mm

Nylon Pipe Spring (For Guarding Nylon Pipe)



Model	Spring Inner Diameter	Suitable Nylon Pipe Outer Dia. x Length	N.W. (g)
SG-41800	Ø4.5	Ø4 x 1800mm	52
SG-61800	Ø6.5	Ø6 x 1800mm	72

Pipe Cutter



Model	Item	N.W. (g)
M25004	Pipe Cutter	30
M25004-1	Blade of Pipe Cutter	2

Manual Pipe Bender

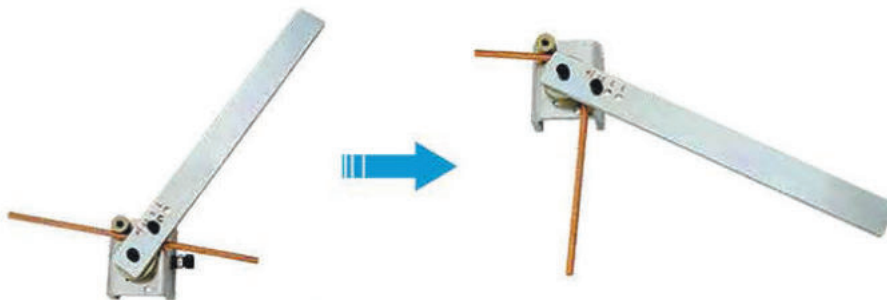

Manual Pipe Bender



Grooved Disks
(Ø4, Ø6, Ø8, Ø10)

◆ Features

1. Manual pipe bender is suitable for manually bending variable kinds of metal pipes, such as aluminum, copper, steel, and iron.
2. Multiple sizes of grooved disks Ø4, Ø6, Ø8, and Ø10 are available for choice upon demand.
3. Each grooved disk can be purchased individually.

◆ Specification Chart

Order Code	Item	N.W. (g)
TB-4-6-8-10	Manual Pipe Bender with Ø4, Ø6, Ø8, and Ø10 Grooved Disks	1591
PC231001	Ø4 Grooved Disk	115
PC232001	Ø6 Grooved Disk	104
PC233001	Ø8 Grooved Disk	174
PC234001	Ø10 Grooved Disk	289

◆ Order Code (Manual Pipe Bender with Grooved Disks)

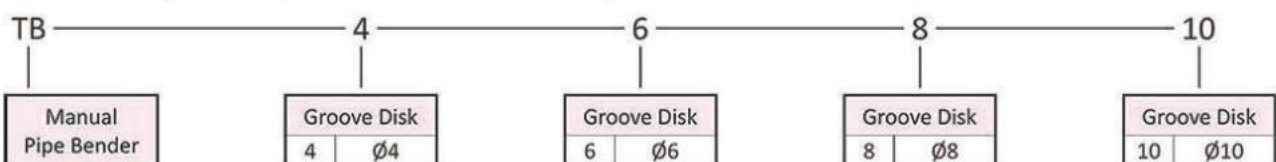

Manual Pipe Bender

◆ Pipe Bender Fixed Instruction

1. Mount the manual pipe bender on a vise or an H-beam.
2. Screw the base with the hexagonal screws to tighten the pipe bender on a vase or an H-beam.

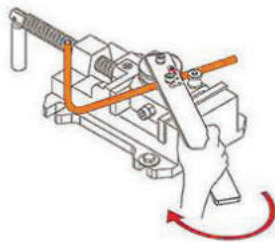

on a Vise

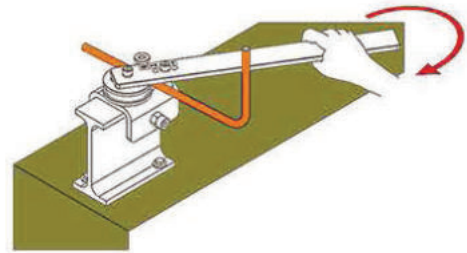

on an H-Beam

◆ Grooved Disk Switch Instruction

- $\varnothing 4$ and $\varnothing 6$ grooved disks

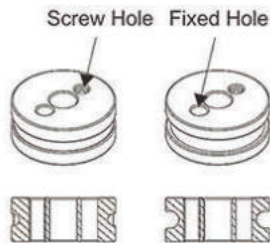

Tighten the screw upwards from the bottom of the pipe bender base to the grooved disks to fix the grooved disks.

- Bending Lever:

Place the grooved disk under the bending lever and fix it on the base holder by the pipe size.

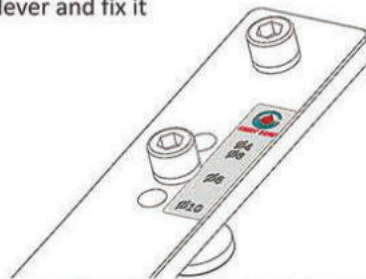

- $\varnothing 8$ and $\varnothing 10$ grooved disks

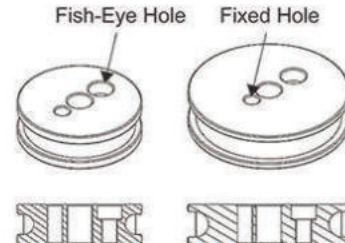

Tighten the screw downwards from the top of the fish-eye hole to the pipe bender base to fix the grooved disks.

◆ Bending Instruction

1. Turn the bending lever to the starting point.

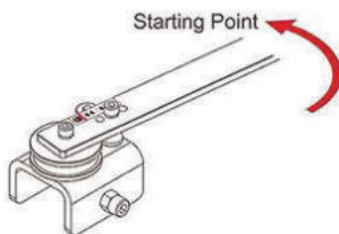

2. Insert the pipe among points A, B, and C and take the length needed for bending.

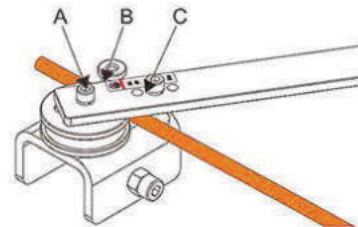

3. Turn the bending lever with strength clockwise to bend the pipe.



4. Turn the bending lever back to the starting point to remove the pipe.

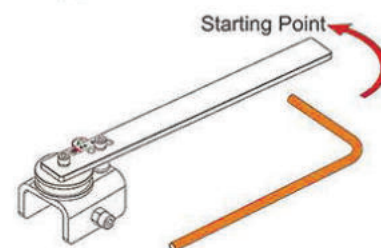

High-Pressure Pipe Clamp



Model	Diameter (mm)	Bore	N.W. (g)
6A	10.5	PT1/8	372
8A	13.8	PT1/4	371
10A	17.3	PT3/8	370
15A	21.7	PT1/2	571
20A	27.2	PT3/4	570
25A	34.0	PT1	678
32A	42.7	PT1-1/4	666
40A	48.6	PT1-1/2	1667
50A	60.5	PT2	1656
65A	76.3	PT2-1/2	3470
80A	89.1	PT3	3432

One-Side-Fixed Pipe Clip



No.	Model	Fixed Hole Number	Suitable Outer Dia. of Pipe	Pipe Number	Thickness (mm)	Width (mm)	Length (mm)	Fixed Hole Dia. (mm)	N.W. (g)
1	PZ-110410	1	Ø4	1	1.0	10	19	5	1.6
2	PZ-120410	1		2	1.0	10	23	5	1.9
3	PZ-130410	1		3	1.0	10	27	5	2.2
4	PZ-140410	1		4	1.0	10	31	5	2.2
5	PZ-150410	1		5	1.0	10	35	5	2.8
6	PZ-110610	1	Ø6	1	1.0	10	21	5	2.0
7	PZ-120610	1		2	1.0	10	27	5	2.5
8	PZ-130610	1		3	1.0	12	33	5	3.6
9	PZ-110810	1	Ø8	1	1.0	10	22	5	2.3
10	PZ-120810	1		2	1.0	12	32	5	3.7
11	PZ-111010	1	Ø10	1	1.0	10	27	5	2.8
12	PZ-121012	1		2	1.2	12	40	5	5.7
13	PZ-111212	1	Ø12	1	1.2	12	32	5	5.0
14	PZ-111516	1	Ø16	1	1.6	20	43	7	14.0
15	PZ-110320	1	3/8" (Ø18.5)	1	2.0	20	47	7	19.4
16	PZ-110420	1	1/2" (Ø21.5)	1	2.0	20	52	7	22.6
17	PZ-112216	1	Ø23	1	1.6	20	48	7	17.0
18	PZ-110620	1	3/4" (Ø26)	1	2.0	20	55	7	26.4
19	PZ-112816	1	Ø29	1	1.6	20	57	7	22.2
20	PZ-113316	1	Ø34	1	1.6	20	64	7	25.2
21	PZ-110820	1	1" (Ø33)	1	2.0	20	64	7	32.6
22	PZ-114220	1	Ø43	1	2.0	20	76	7	40.0
23	PZ-115020	1	Ø51	1	2.0	20	83	7	45.0
24	PZ-116020	1	Ø61	1	2.0	20	95	7	54.0

Saddle Pipe Clip

Saddle Pipe Clip / Saddle Pipe Clip Set (with a Saddle Pipe Clip, a Mounting Base, and Two Screws)



No.	Model	Fixed Hole No.	Pipe Dia.	Pipe No.	Thickness (mm)	Width (mm)	Length (mm)	Distance Between Fixed Holes (mm)	Fixed Hole Dia. (mm)	N.W. (g)
1	PZ-220415	2	Ø4	2	1.5	13	47	32	7	6.4
2	PZ-230415	2		3	1.5	13	47	32	7	6.6
3	PZ-240415	2		4	1.5	12	47	35	5	6.3
4	PZ-250415	2		5	1.5	13	55	38	7	7.7
5	PZ-210615	2	Ø6	1	1.5	13	45	30	7	6.6
6	PZ-220616	2		2	1.6	12	46	30	7	6.8
7	PZ-230616	2		3	1.6	12	54	37	7	8.0
8	PZ-240616	2	4	1.6	12	54	40	40	6.5x8	8.0
9	PZ-210816	2	Ø8	1	1.6	13	45	30	7	7.5
10	PZ-211016	2	Ø10	1	1.6	13	45	30	7	8.0
11	PZ-231016	2		3	1.6	12	66	51	7	10.4
12	PZ-241016	2	4	1.6	15	77	62	7x9	14.8	
13	PZ-211216	2	Ø12	1	1.6	13	45	30	7	8.4
14	PZ-221216	2		2	1.6	10	53	39	5x7	7.7
15	PZ-221515	2	Ø15	2	2.0	20	80	61	7x9	28.0
16	PZ-212816	2	Ø28	1	1.6	20	74	57	7	25.0

Saddle Pipe Clip Set (with a Saddle Pipe Clip, a Mounting Base, and Two Screws)



No.	Model	Fixed Hole No.	Pipe Dia.	Pipe No.	Part	Thickness (mm)	Width (mm)	Length (mm)	Distance Between Fixed Holes (mm)	Fixed Hole Dia. (mm)	N.W. (g)
1	PZ-340415	2	Ø4	4	Pipe Clip	1.5	12	47	35	5	6.3
					Base	3.0	13	50	35	M8xP0.8	15.2
2	PZ-350415	2		5	Pipe Clip	1.5	13	55	38	7	7.7
					Base	3.0	13	57	37	M6xP1.0	18.0
3	PZ-310615	2	Ø6	1	Pipe Clip	1.5	13	45	30	7	6.6
4	PZ-320616	2		2	Pipe Clip	1.6	12	46	30	7	6.8
5	PZ-330616	2		3	Pipe Clip	1.6	12	54	37	7	8.0
					Base	3.0	13	57	37	M6xP1.0	18.0
6	PZ-340616	2		4	Pipe Clip	1.6	12	54	40	6.5x8	8.0
					Base	3.0	13	57	40	M6xP1.0	18.0
7	PZ-310816	2	Ø8	1	Pipe Clip	1.6	13	45	30	7	7.5
				2	Pipe Clip	1.6	12	53	36	7	8.1
8	PZ-360816	2		6	Base	3.0	13	57	37	M6xP1.0	18.0
					Pipe Clip	1.6	15	80	65	7	15.2
9	PZ-311016	2	Ø10	1	Pipe Clip	1.6	13	45	30	7	8.0
10	PZ-331016	2		3	Pipe Clip	1.6	12	66	51	7	10.4
					Base	3.0	13	70	51	M6xP1.0	22.0
11	PZ-341016	2		4	Pipe Clip	1.6	15	77	62	7x9	14.8
					Base	3.0	15	82	65	M6xP1.0	31.0
12	PZ-311216	2		Ø12	1	Pipe Clip	1.6	13	45	30	7
13	PZ-321216	2	2		Pipe Clip	1.6	10	53	39	5x7	7.7
					Base	3.0	13	57	40	M5xP0.8	18.1

※ Each model goes with 2 screws. The net weight of the M6xP1.0x10L screw is 3.3g, and the M5xP0.8x10L screw is 2.2g.

HV-200, HV-201 Air Operated Oil Filler



◆ Features

1. Both HV-200 and HV-201 are without oil tanks that can work with any oil tank size.
2. HV-200 is without a rack, but HV-201 is that a five-gallon oil tank can place on top of it.
3. It is suitable for various engine oil, lubricants, and gear oil.
4. Oil filling and extracting are driven by a pneumatic motor pump. No contact between the oil and the air prevents the oil from being emulsified.
5. The oil refilling gun or the air pressure can control the speed of filling oil. The oil refilling gun is a standard accessory.
6. It can add a digital flow meter to measure the volume of the refilled oil as optional.

◆ Specification

Model	Rack	Capacity (L)	Dimensions (mm)	Filling Method	Power	Operation Pressure	N.W.	G.W.
HV-200	X	X	200x190x300	Air Pressure	AP-35	5~7 KG/cm ²	7 kg	7.5 kg
HV-201	O	20	360x390x790				10 kg	11.0 kg

Air Operated Grease Filler



◆ Features

1. The barrel body is made of a high-quality steel plate that is more durable.
2. The inside diameter of the barrel is 350 mm, and the inside height is 430 mm, which can suit any five-gallon grease tank.
3. Driven by compressed air, the pump has two independent circulation systems, so the compressed air will not touch the grease in the barrel, which can prevent the grease from deteriorating.
4. It is equipped with four turn-able wheels for easy pushing around.
5. It is suitable for operating in a cold climate.
6. Suitable for grease NLGI grade 000-2.
7. Suitable for many kinds of machinery, vehicles, ships, etc.

◆ Specification

Model	Capacity	Air Input Pressure	Pressure Ratio	Grease Output pressure	Discharge Volume	Hose Length	Viscosity	N.W.	G.W.
CKMG-55	20	4~9 kgf/cm ²	45:1	180~450 kgf/cm ²	16.5 g/sec	10 meters	NLGI 000~2	16.6 kg	21.1 kg

Adjustable Automatic Grease Lubricator



GP-36C



GP-26C

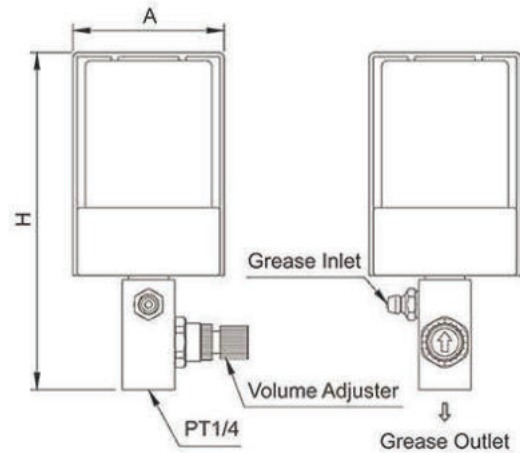

GP Dimensional Drawing



OP-26C

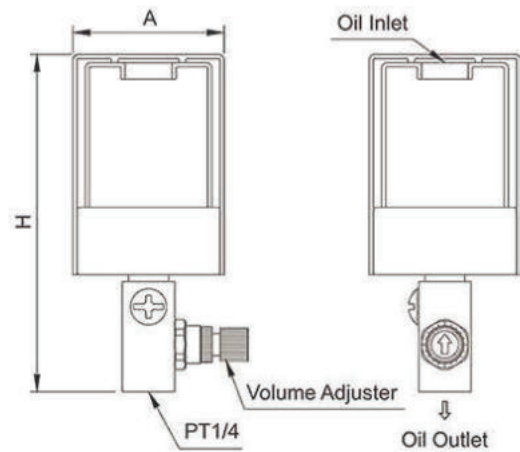

OP Dimensional Drawing

◆ Features

- Adjustable Automatic Lubricators are divided by lubricant types. GP models are for grease use. OP models and CP-36C are for oil use.
- All models can automatically deliver the lubricant to a single lubrication point steadily.
- GP and OP models include three types of adapters, PT 1/4-19, PT 1/8-28, and 1/4-28UNF.
- CP-36 equips a brush but without adapters.
- All models are suitable for lubricating linear guides, bearings, and motor shafts.
- All models have volume adjusters that enable the users to adjust the volume of lubricant upon needs. For OP models and CP-36C, twist the volume adjusters clockwise to the zero point when they are not in use.
- Instruction for filling lubricant:
 - GP models: fill grease through grease nipples and close the grease nipple cap after filling up the grease to prevent the air or impurities from entering the grease tank.
 - OP and CP-36C models: remove the transparent oil cover, fill the oil through the oil inlet, and put the oil cover back after finishing.
- Do not use organic solvents such as toluene or carbon tetrachloride to clean the lubricant tank.

◆ Specification

Model	Suitable Viscosity	Capacity	Suitable Temperature	Adapters	H (mm)	A (mm)	N.W. (kg)
GP-26C	NLGI 0~2	78 g	-20°C~125°C	PT1/4-19	120.0	Ø55	0.20
GP-36C		150 g			134.5	Ø68	0.25
OP-26C	Oil	78 g		PT1/8-28	120.0	Ø55	0.22
OP-36C		150 g			134.5	Ø68	0.25
CP-36C W/Brush		150 g		NONE	229.5	Ø68	0.32

Special Request Order Code Abbreviated Index

◆ Float Switch for Oil

SO: NO Contact Float Switch (Signal sent when oil level is high.)

SC: Add a NC Contact Float Switch (Signal sent when oil level is low.)

SO: Add a NO Contact Float Switch (Signal sent when oil level is high.)

◆ Level Switch for Grease

RC: Add a NC Contact Magnetic Level Switch (Signal sent when grease level is low.)

RO: Add a NO Contact Magnetic Level Switch (Signal sent when grease level is high.)

KC: Add a NPN, NC Contact Capacitive Level Switch (Signal sent when grease level is low.)

KO: Add a NPN, NO Contact Capacitive Level Switch (Signal sent when grease level is high.)

◆ Pressure Switch

PC: Add a NC Contact Pressure Switch (Signal sent when pressure is below a preset value.)

PO: Add a NO Contact Pressure Switch (Signal sent when pressure exceeds a preset value.)

AO: NO Contact Air Pressure Switch (Signal sent when pressure exceeds a preset value.)

HO: NO Contact High Oil-Pressure Switch (Signal sent when pressure exceeds a preset value.)

LO: NO Contact Low Oil-Pressure Switch (Signal sent when pressure exceeds a preset value.)

◆ Reed Switch

TC: Add a NC Contact Reed Switch (Signal sent when the stroke is abnormal.)

TO: Add a NO Contact Reed Switch (Signal sent when the stroke is normal.)

◆ Other

1 : Turn-on-feeding mode: Operation time starts first after the power is on.

2 : Turn-on-interval mode: Interval time starts first after the power is on.

B : Add a Lager Buzzer (Available for CEN01, CEN02, CESG02, CENA, CEN03, CEN04, CESG04, CENB, COA only)

C : Add a Magnetic Filter (Available for PNA /PNB 3L and above tanks only)

D : Add a Partition (Available for PNA/PNB 3L, 4L resin tanks, and 8L iron tanks only)

F : Add a Feed-Oil Button (Available for CEV, CEVB only)

G : Add a Pressure Gauge

H : Add a CE Certified Connector (Available for CESSB only)

L : Add a Power Indicator Light (Available for CEV, CESMA/B, CEVB only)

M: Customized Motor Power

Z : Increase Discharge Volume to 260cc/min (Available for CEN01, CESG01, CEN02, CEN03, CESG03, CEPB, CEWB, CEN04, CESG04 only)

AF : Add an Air Filter Regulator (Available for PNC03)

BF : Add an A-101-2 Filter (Available for PNC03)

OB : Add an OB Spray Gun

OC : Add an OC Oil-Air Volume Distributor (Please refer to OC catalog and provide order code)

BM : Add an OB Spray Gun with a Magnetic Base



CEN01
P. 04

CESG01
P. 05



CEN02
P. 12

CESG02
P. 13

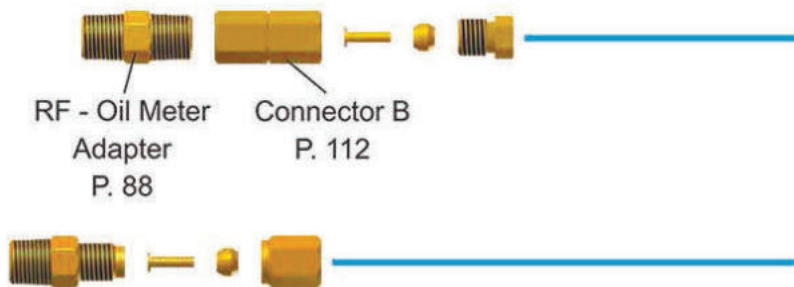

RF - Oil Meter
Adapter
P. 88



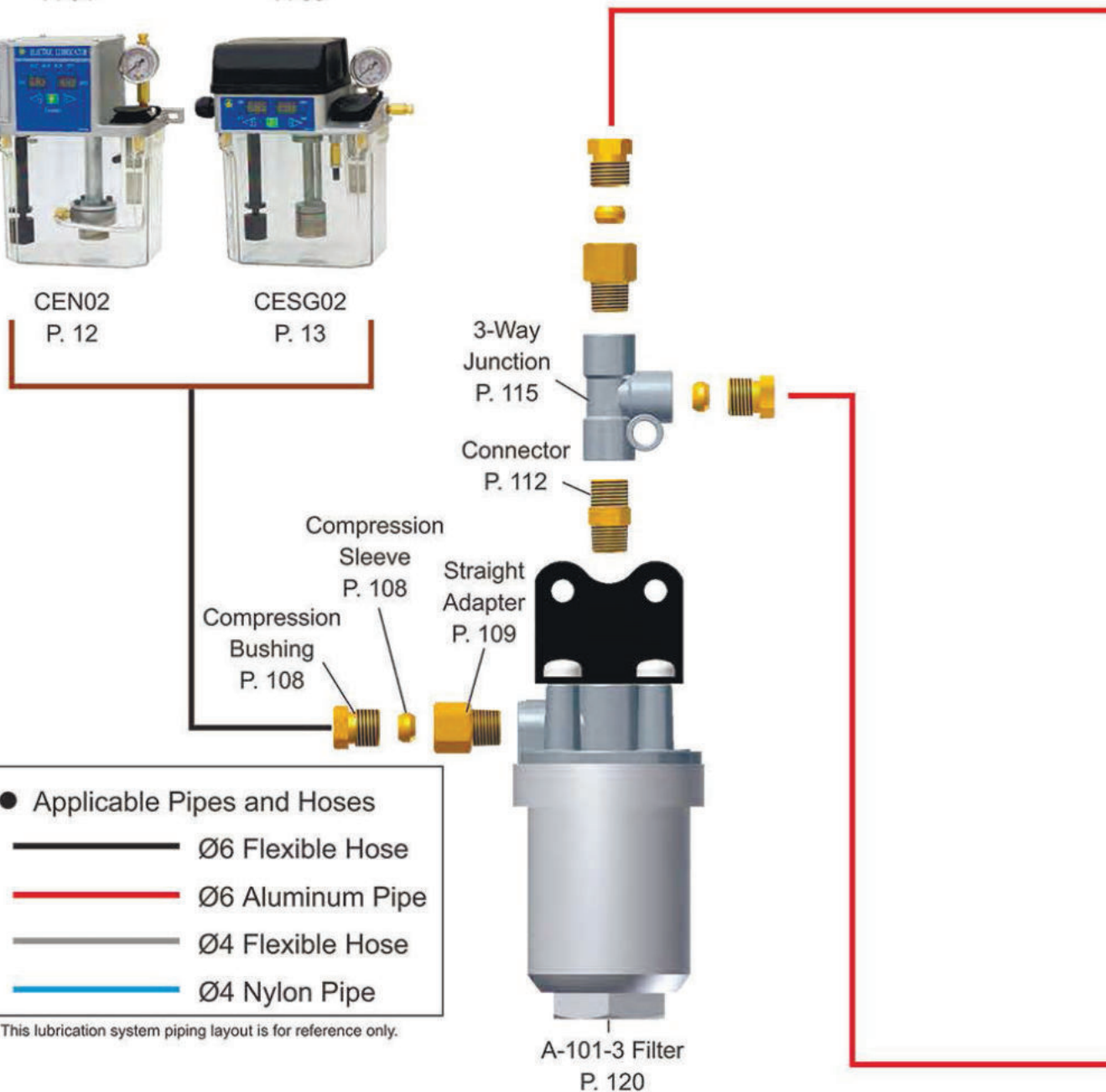

Connector B
P. 112

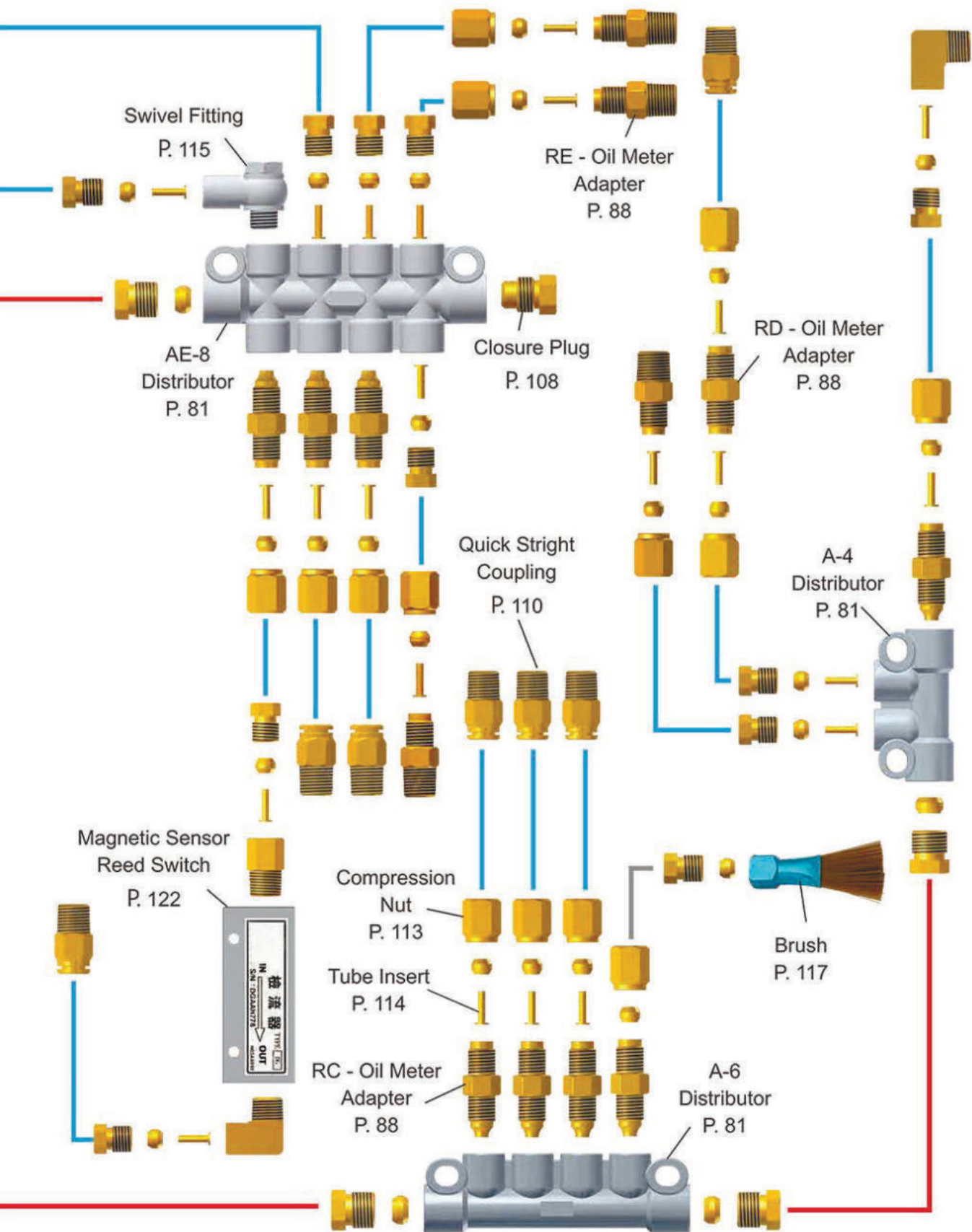

- Applicable Pipes and Hoses
- Ø6 Flexible Hose
- Ø6 Aluminum Pipe
- Ø4 Flexible Hose
- Ø4 Nylon Pipe

※ This lubrication system piping layout is for reference only.



- Applicable Pipes and Hoses
-  Ø8 Aluminum Pipe
 -  Ø6 Flexible Hose
 -  Ø6 Copper Pipe
 -  Ø4 Nylon Pipe
 -  Circulating Oil Pipe

※ This lubrication system piping layout is for reference only.

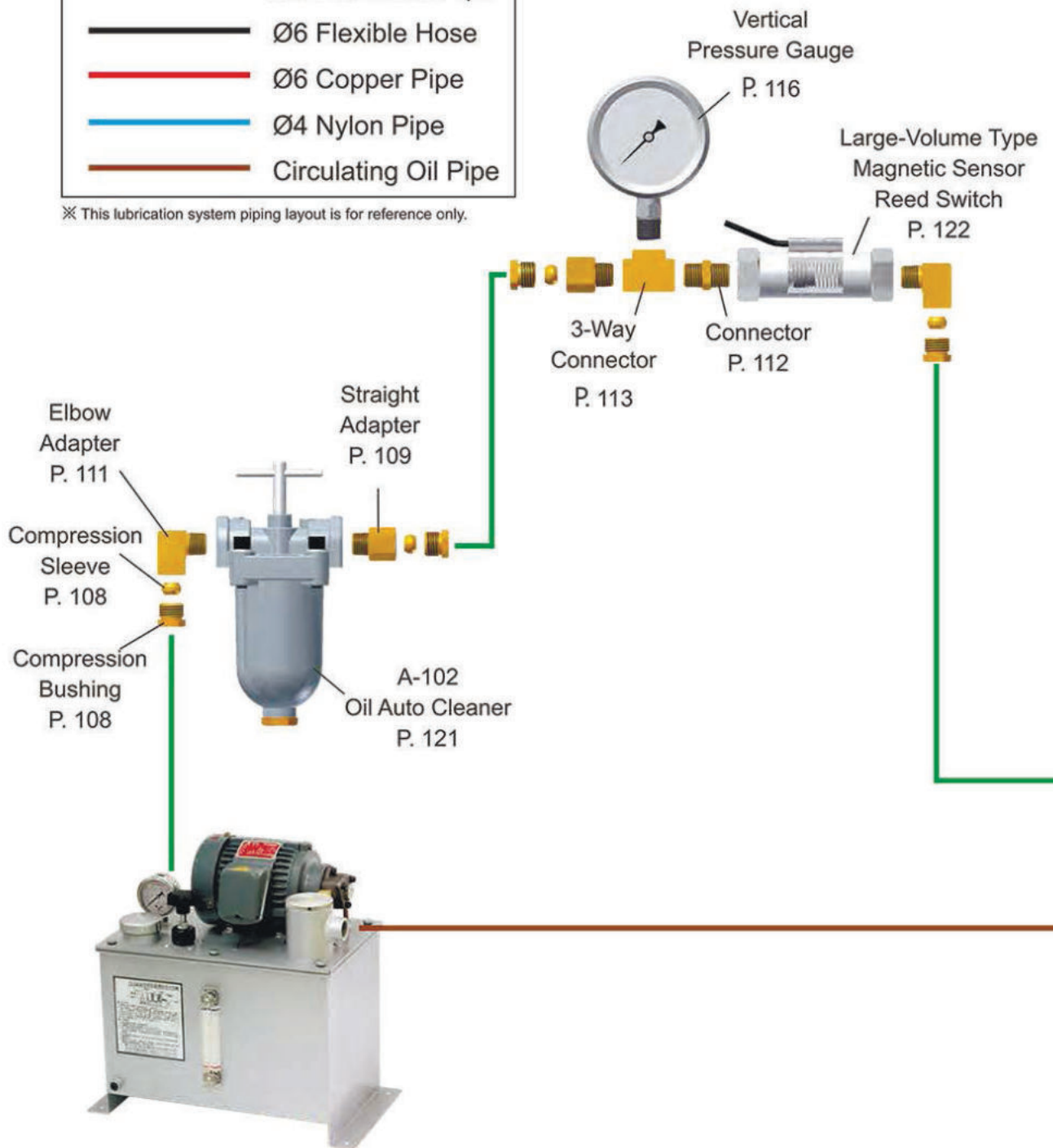

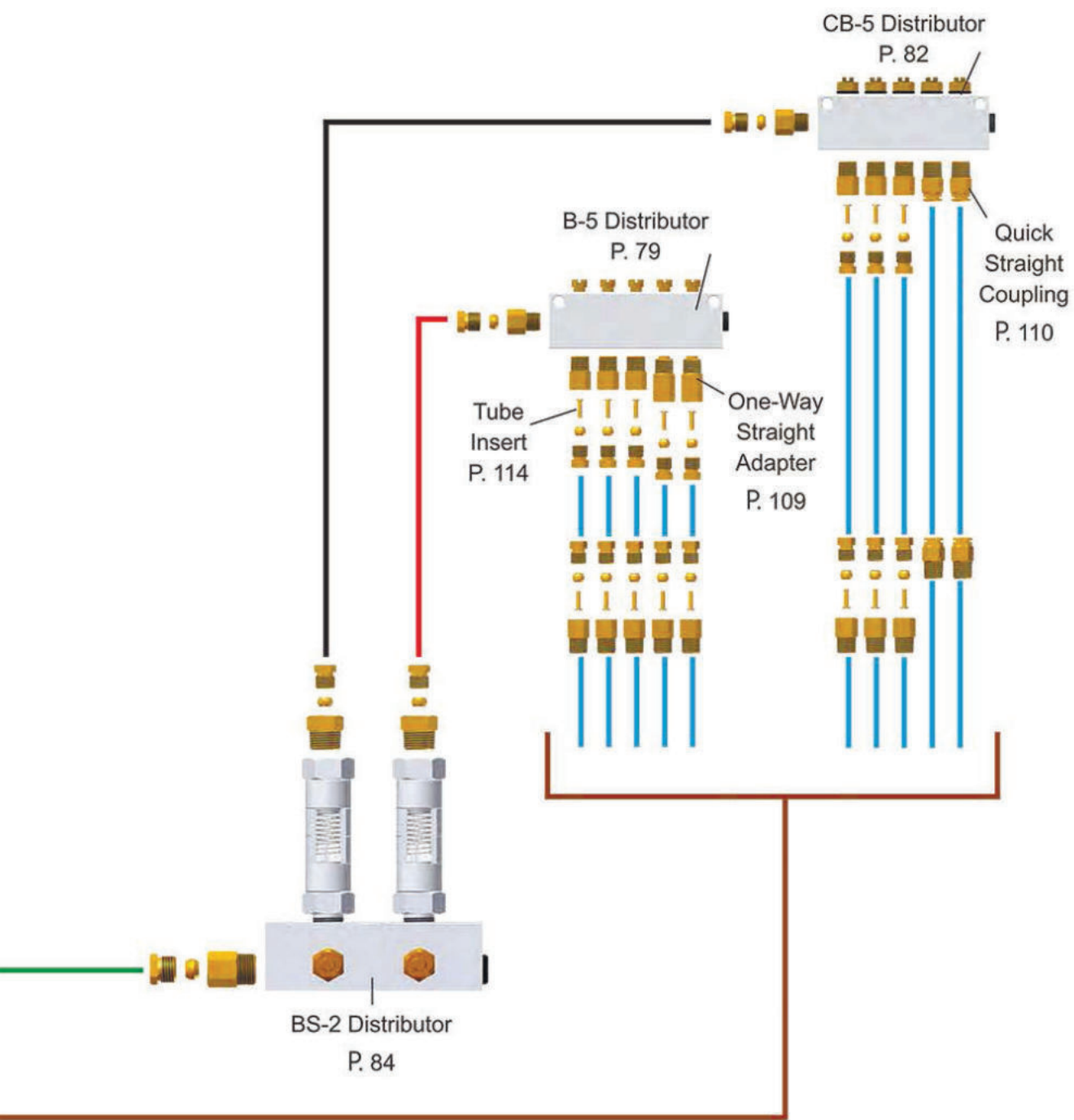

CLSB Circulating Type Oil Electric Lubricator
P. 23

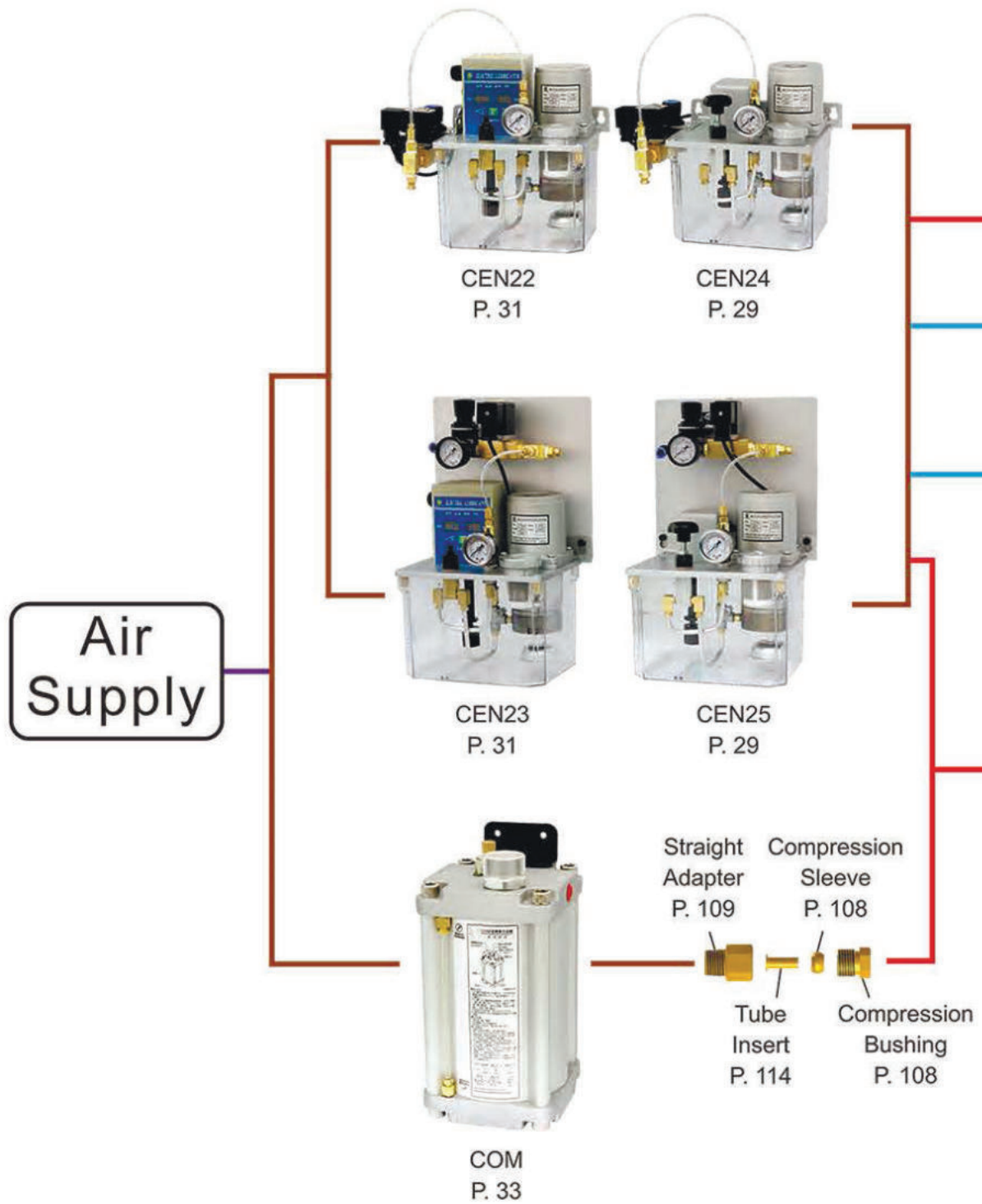

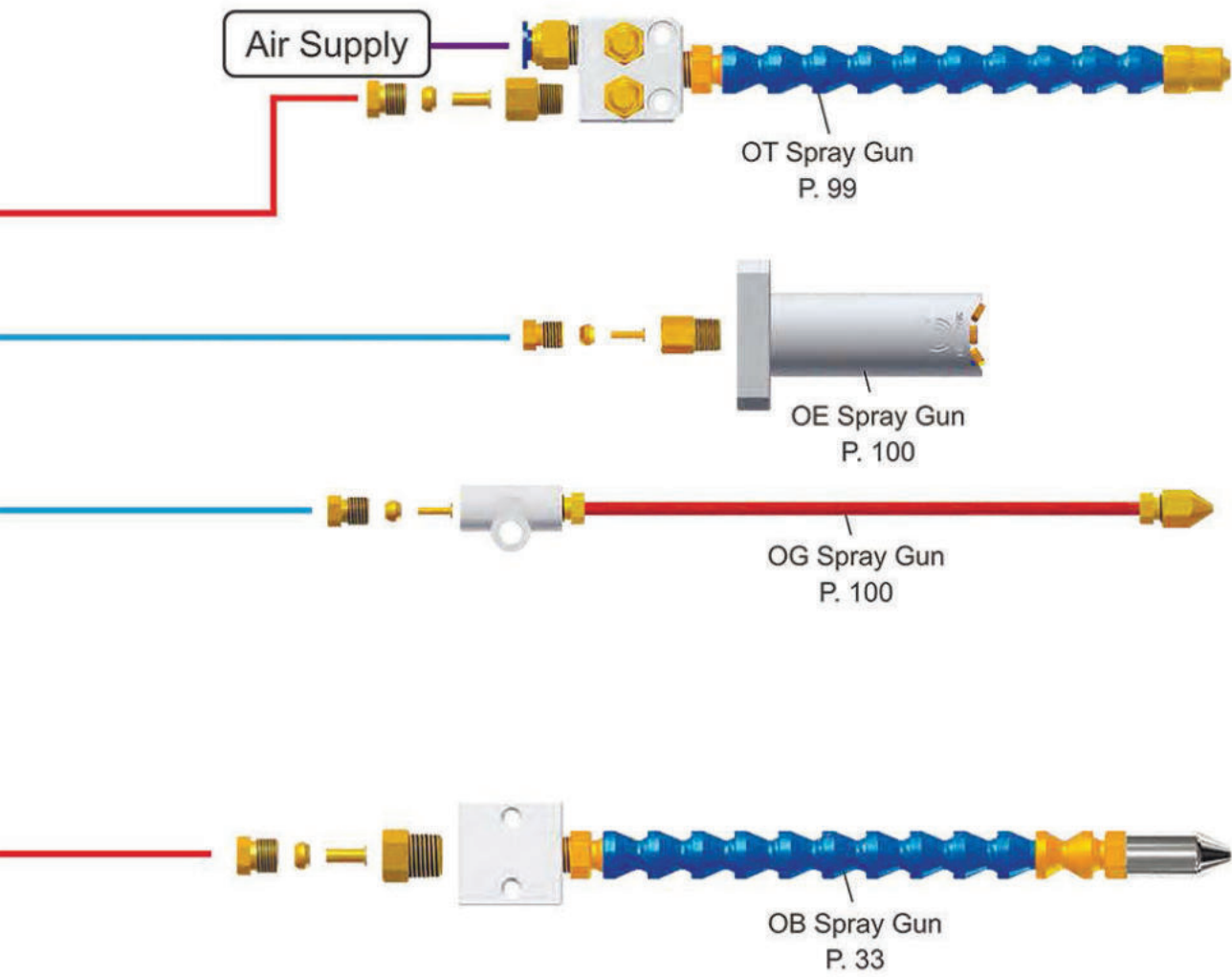



● Applicable Pipes	
	Ø8 Nylon Pipe
	Ø6 Nylon Pipe
	Ø4 Nylon Pipe

※ This lubrication system piping layout is for reference only.

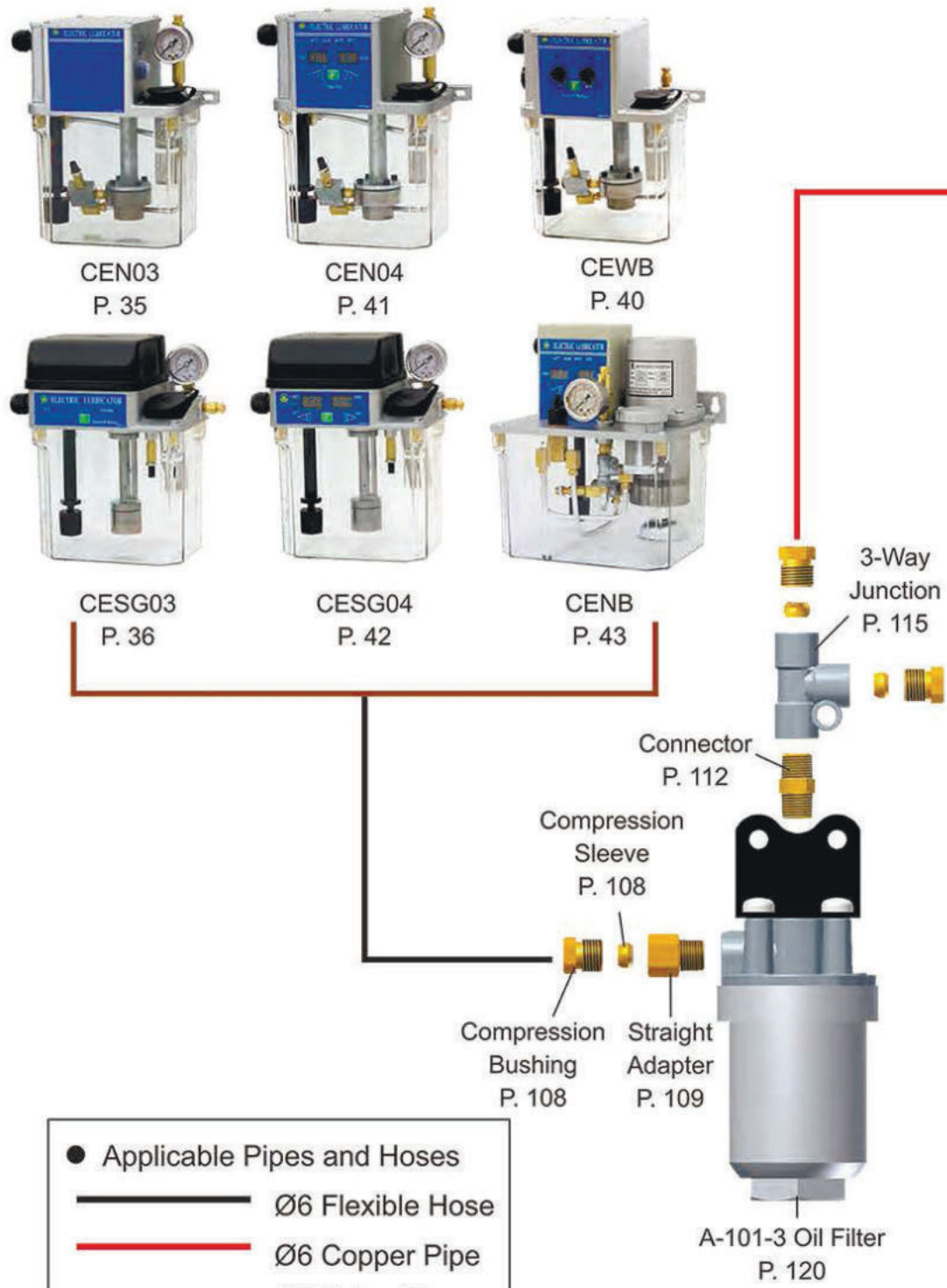

※ This lubrication system piping layout is for reference only.

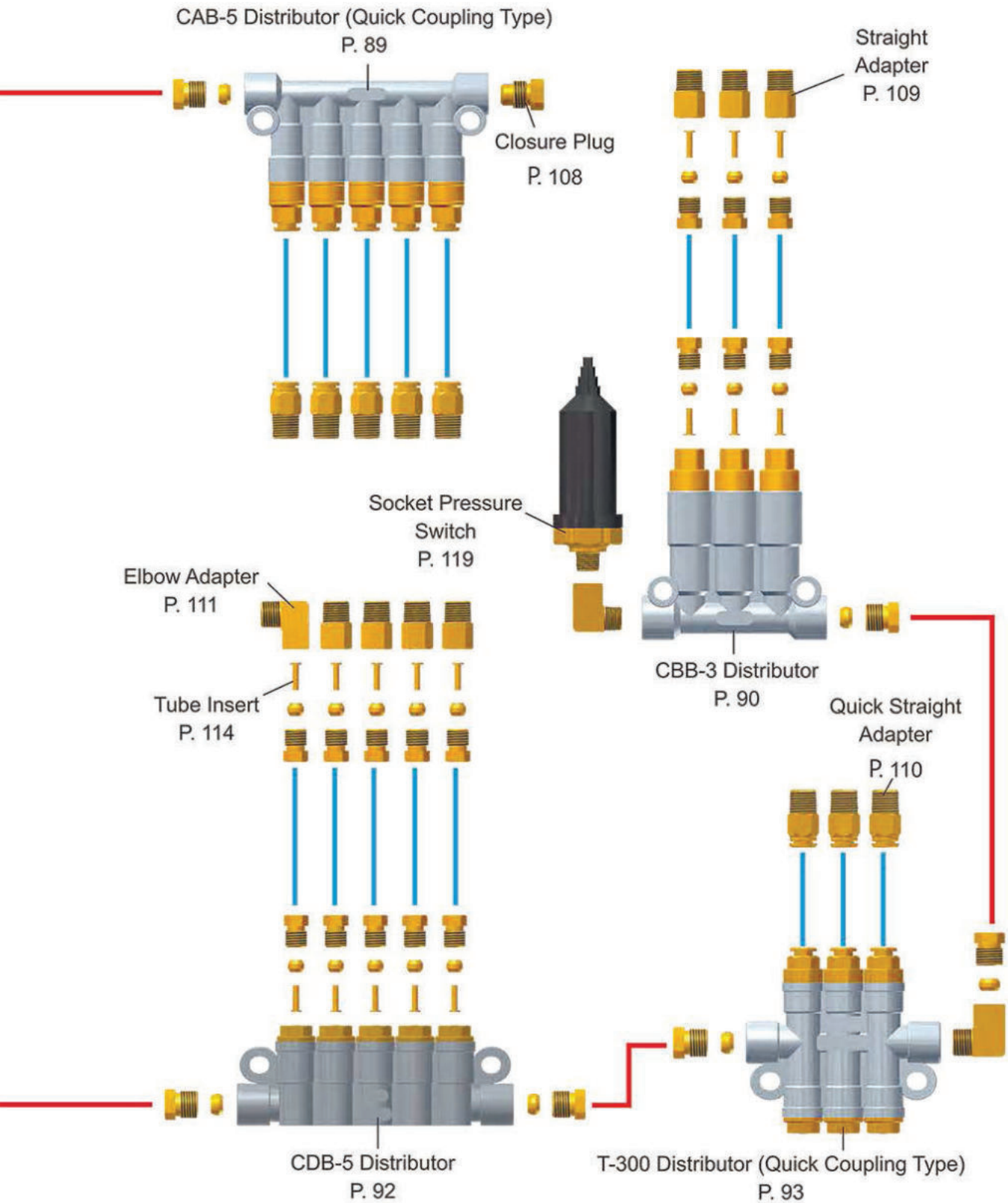

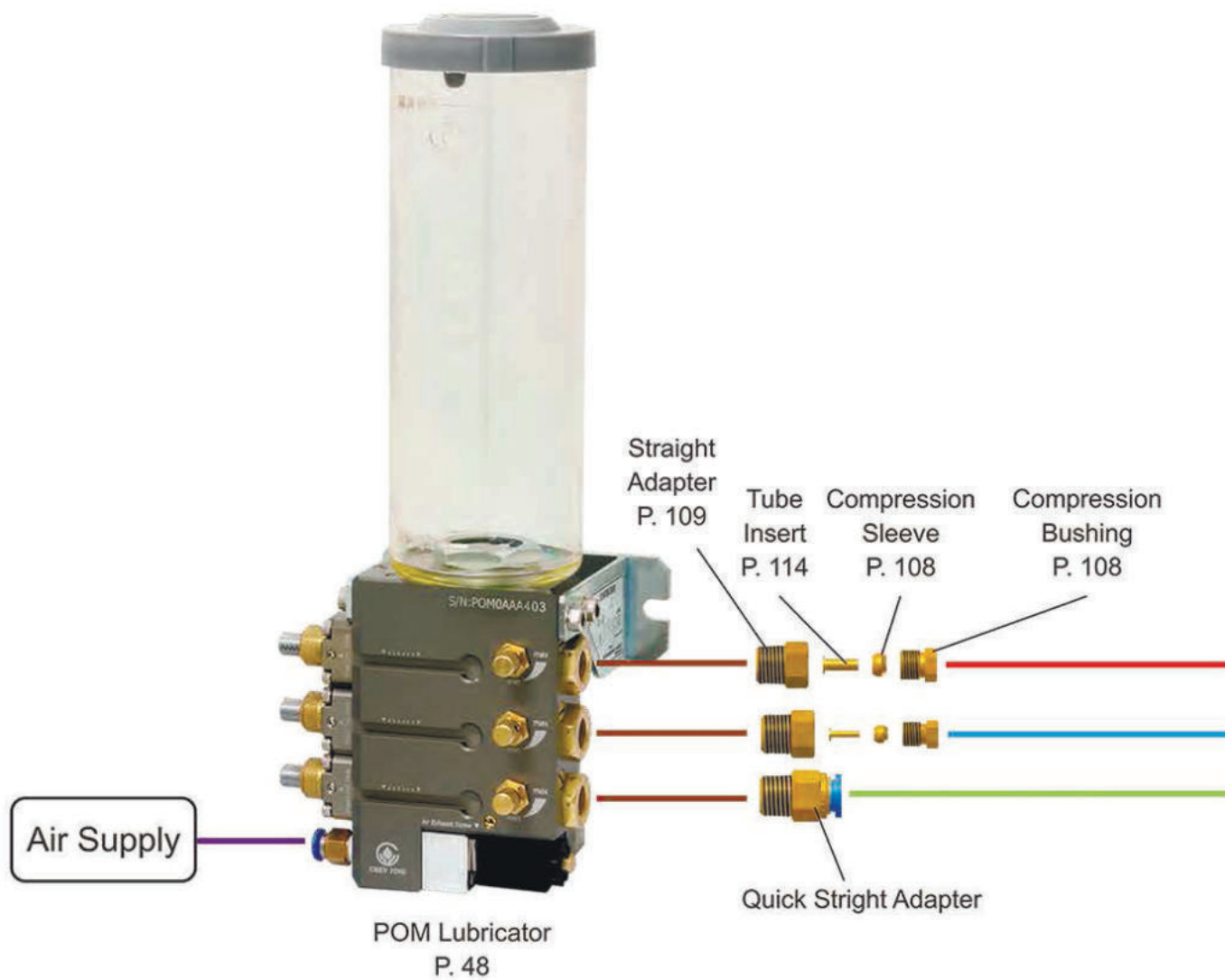

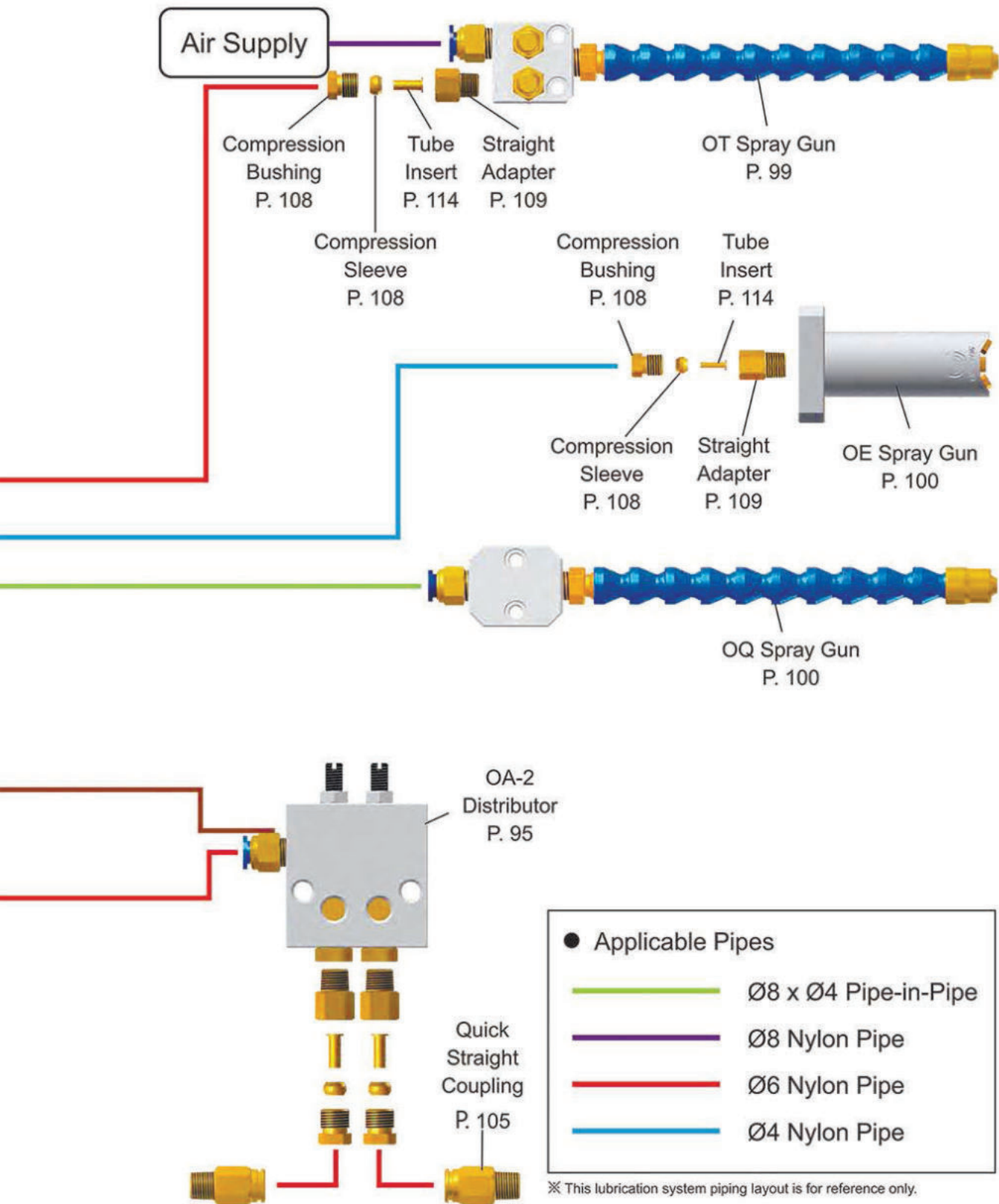



KGA
P. 55

KGC
P. 57

KGH
P. 59

KACP
P. 61



KSB
P. 63



KGN
P. 65



KGNV
P. 67

● Applicable Pipes and Hoses

- Ø6 High-Pressure Flexible Hose
- Ø4 Nylon Pipe

※ This lubrication system piping layout is for reference only.

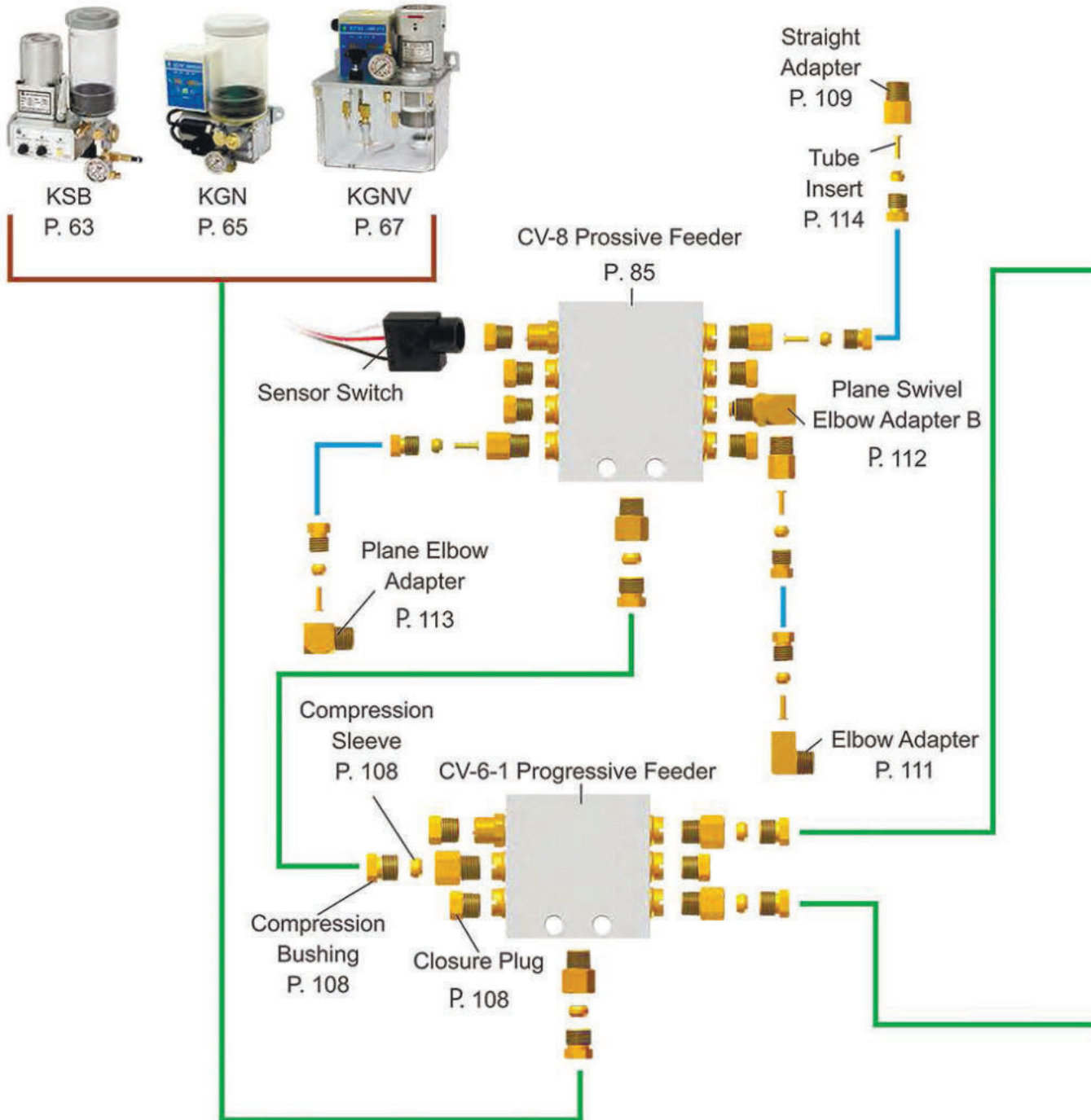

Flexible Hose

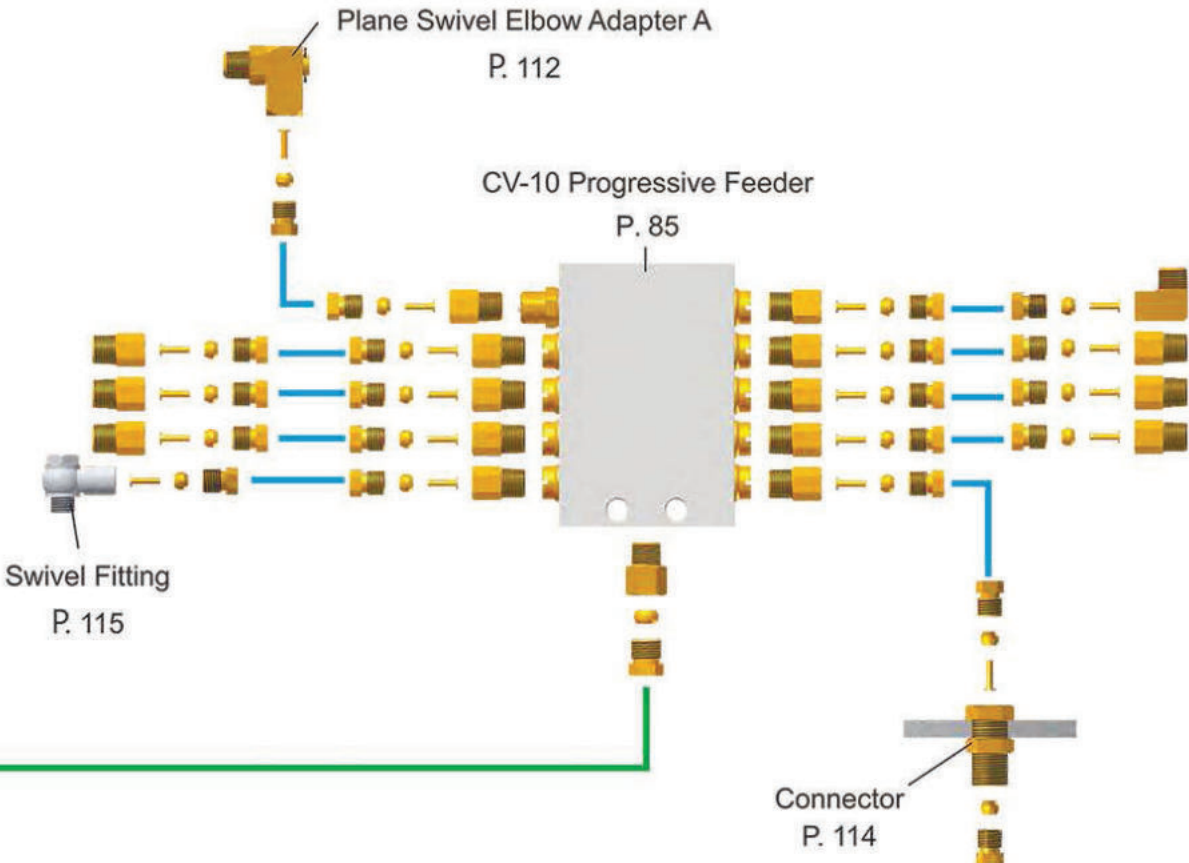
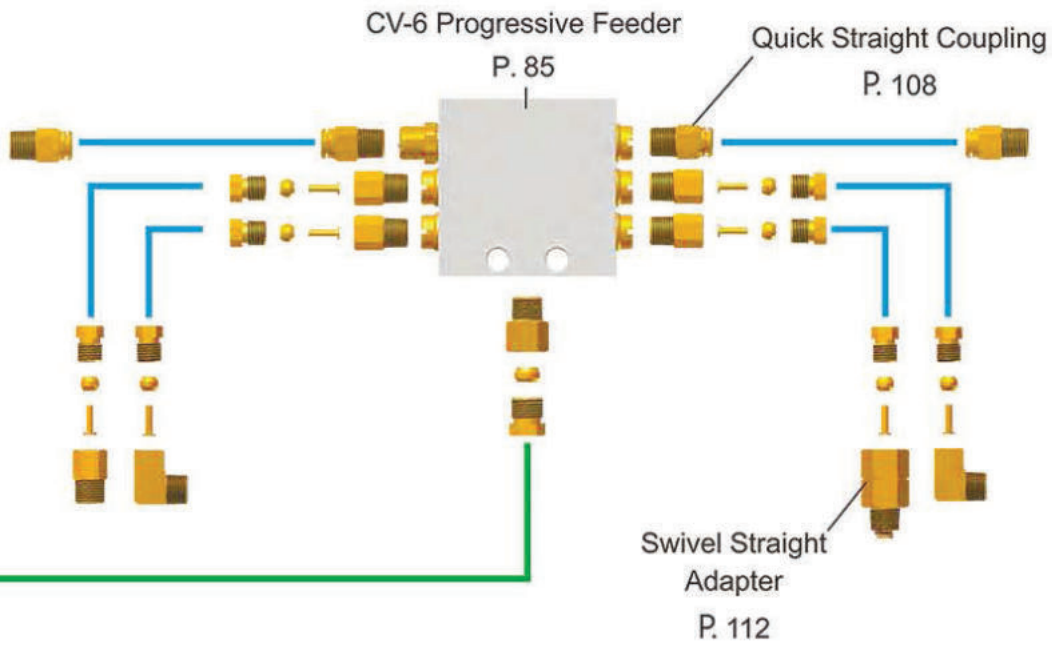



KGB
P. 69

KGBP
P. 69

KGVB
P. 73

KGNVB
P. 74



KGNB
P. 75



KGNBP
P. 75



KAB
P. 71



KABP
P. 71



Compression Bushing P. 108 Straight Adapter P. 109

Compression Sleeve P. 108



D-03 Distributor

- Applicable Pipes and Hoses
- Ø8 High-Pressure Flexible Hose
- Ø4 Nylon Pipe

※ This lubrication system piping layout is for reference only.

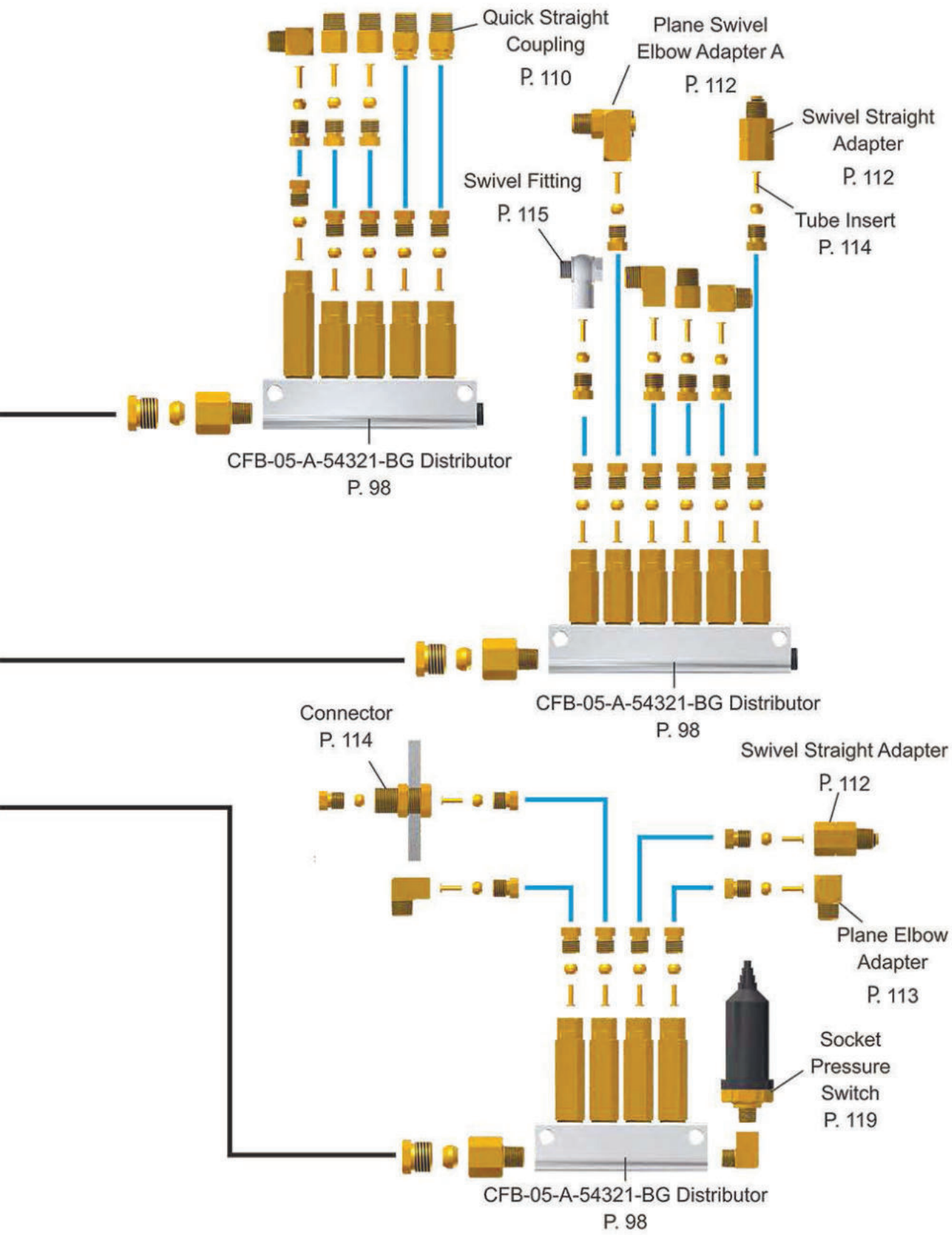

Customization Lubrication Systems

With more than 45 years of professional experience, we can customize and design for various unique specifications upon request. We also provide consultation service for all our customers.



Safety Instruction, Maintenance, and Warranty

◆ Electrical Safety

1. To prevent electrical shock hazards, turn off the power while assembling or repairing this lubricator.
2. Ensure that the power supply is shutdown before unplugging the electric wire from the machinery.
3. Check the setting of the power supply if it is the correct voltage.
4. If the motor's power supply is damaged, do not try to repair it yourself. Contact a qualified service technician immediately.
5. Avoid operating the unit in a humid environment. Recommend installing an earth leakage circuit breaker (ELCB) to prevent possible shock hazards.

◆ Operation Safety

1. Ensure that all the piping, cables, and accessories are correctly connected before operating.
2. If the work environment is full of dust and humidity with significant temperature fluctuation, those factors might shorten the lifetime of this lubricator unit.
3. Place the lubricator unit on stable work surfaces to avoid shaking damage.

◆ Prohibition

1. Forbid filling used oil, molybdenum disulfide, corrosive substance, or any volatile liquid that may damage the function of the lubricator unit. The warranty does not cover any malfunction due to improper use.
2. Do not fill the oil without the oil filter to prevent impurities from going through the oil tank and causing the piping to be blocked.
3. Do not shake or drop the lubricator unit violently.
4. Do not operate this unit under a temperature of 0°C or above 60°C.
5. Do not operate or repair this unit if you are not a qualified service technician to prevent the product breakdown or possible hazards.

◆ Maintenance

1. Please do routine maintenance and check all the oil pipes, adapters, and connectors regularly. Replace the new oil pipes, adapters, and connectors immediately if leakage and damage are found.
2. Always keep this operation manual in a reachable place.
3. A daily check is essential to ensure the best performance of this lubricator unit. A complete maintenance check is required every six months of continuous operation.
4. To prevent electrical shock hazards, disconnect all electrical power before the maintenance and repair of this lubricator unit.

◆ Warranty Service

1. We provide a one-year limited warranty at the time of the lubricator's original purchase. After the warranty period, any replacement parts will be charged.
2. Please keep the serial number label on the lubricator for future warranty checks. We will not provide warranty service without the serial number.
3. After applying for warranty service, we will request the defective unit returned to us to clarify the responsibility attribution. Once we receive the defective lubricator unit, we will provide the testing report after the examination. If the buyer has fault liability, the buyer will bear the bill of return shipping expense and inspection fee.
4. After applying for warranty service, if the buyer requests a new unit for replacement before the cause is clarified, the defective unit should return to us within six months. If not, the buyer should pay for the new unit, closing the warranty application.
5. No warranty shall be claimed if the followings cause the damage to lubricator unit:
 - a) The damage caused by improper repairing or modifying the lubricator unit without VKE Technicians' authorization.
 - b) Use improper oil that causes damage to the lubricator.
 - c) The damage caused by improper carry or drop or mishandled.
 - d) The damage caused by a natural disaster, such as floods, earthquakes, typhoons, and hurricanes.
 - e) The damage caused by improper use or other factors, such as installation errors or connecting the wrong voltage,

is not the manufacturer's responsibility.

- f) The damage caused by not following the instruction manual.

◆ Return Policy

1. Do not ship your malfunctioning product back to VKE before contacting our sales department.
2. We will guide you to troubleshoot first to see if the problem can be solved. If it still exists after troubleshooting, we require the malfunctioning parts back for examination before we send the replacement.
3. Return shipping is prepaid by the customer. We suggest that you insure your package and use a shipping method that provides tracking information. VKE is not responsible if the package gets lost or damaged in transit to VKE.
4. After examination, if the problem of the malfunctioning parts is caused by VKE factory, we will send the parts to you after repairing is done. Your return shipping cost will be reimbursed.
5. If VKE factory is not responsible for the problem, we will provide you a quotation for repairable parts. If the customer decides not to repair, the malfunctioning parts will be held for 30 days after notifying the customer repair report or can be handled upon the customer's instructions. The malfunctioning parts will be discarded after 30 days' notice if we do not receive any response.

Safety Instruction, Maintenance, and Warranty

Warranty Return Form

Please complete all fields of this form. By returning this Warranty Return Form to Chen Ying, you agree with our Warranty Terms and Return Policy described on page 147.

1. Customer Information

Company Name:
Address:
Contact Person Full Name:
Phone Number:
Fax Number:
Email Address:
Appointed Courier: <input type="radio"/> DHL/ <input type="radio"/> TNT / <input type="radio"/> FedEx / <input type="radio"/> UPS / <input type="radio"/> Other:
Courier Account Number:

2. Malfunctioning Product Information

VKE Proforma Invoice Number:
Your Purchase Order Number:
Malfunctioning Product Type/ Model / Specifications: lubricator: <input type="checkbox"/> Distributor: <input type="radio"/> Motor / Oil Pump: <input type="radio"/> Other:
Product Serial Number:
Malfunctioning Product Quantity:
Date of Problem Happened:
Details of Problem:
Suspected Cause:
Additional Comments:
Your Signature:
Date: DD/MM/YYYY



Certificate of authorization

Exclusive Distributor

We hereby certify that

Company "Bazovaja tehnika"(Basic technique)

OGRN 1147847189511

is the exclusive distributor for VKE Components and the only representative office in Russia, Belarus, Kazakhstan and ex-CIS countries. It has the rights to give the subdealer's rights to other companies at the area.

January 25th, 2024

A handwritten signature in blue ink, appearing to read 'Kim Yoon Koon', with a horizontal line underneath.

/Kim, Yoon Koon
CEO

Контакты ООО "Базовая техника"

Реквизиты компании

ООО "Базовая техника"

Юридический адрес: 195197, Россия, Санкт-Петербург, Кондратьевский проспект, 15, корп. 5Б

Фактический адрес: 195197, Россия, Санкт-Петербург, Кондратьевский проспект, 15, корп. 5Б

ИНН 7814613087

ОГРН 1147847189511

Время работы

Пн - Пт 8:30 - 17:30

Перерыв на обед 12:30 - 13:00

Сб - Вс - Выходной

Отгрузка товара

пн-пт с 9:00 до 16:00

Офис и склад в Санкт-Петербурге

195197, Россия, Санкт-Петербург, Кондратьевский проспект, 15, корп. 5Б

