

**Standard Shafts**

**VKE**

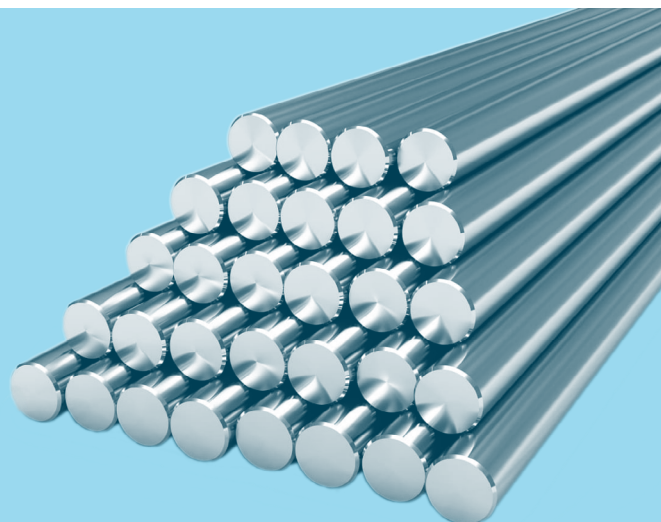

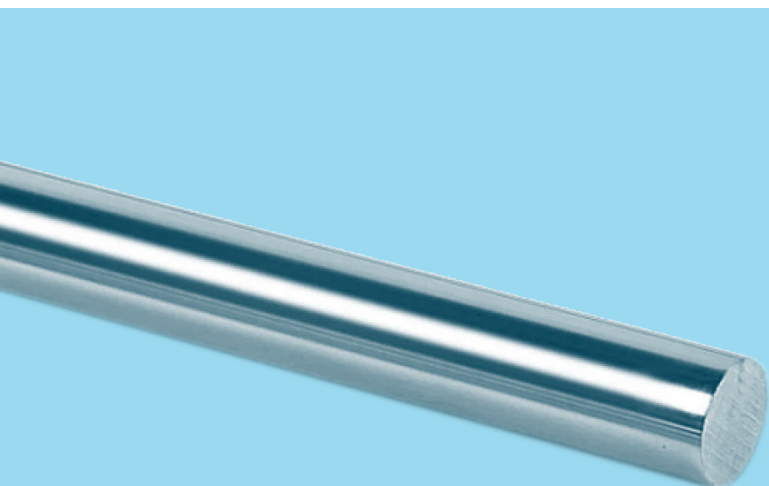
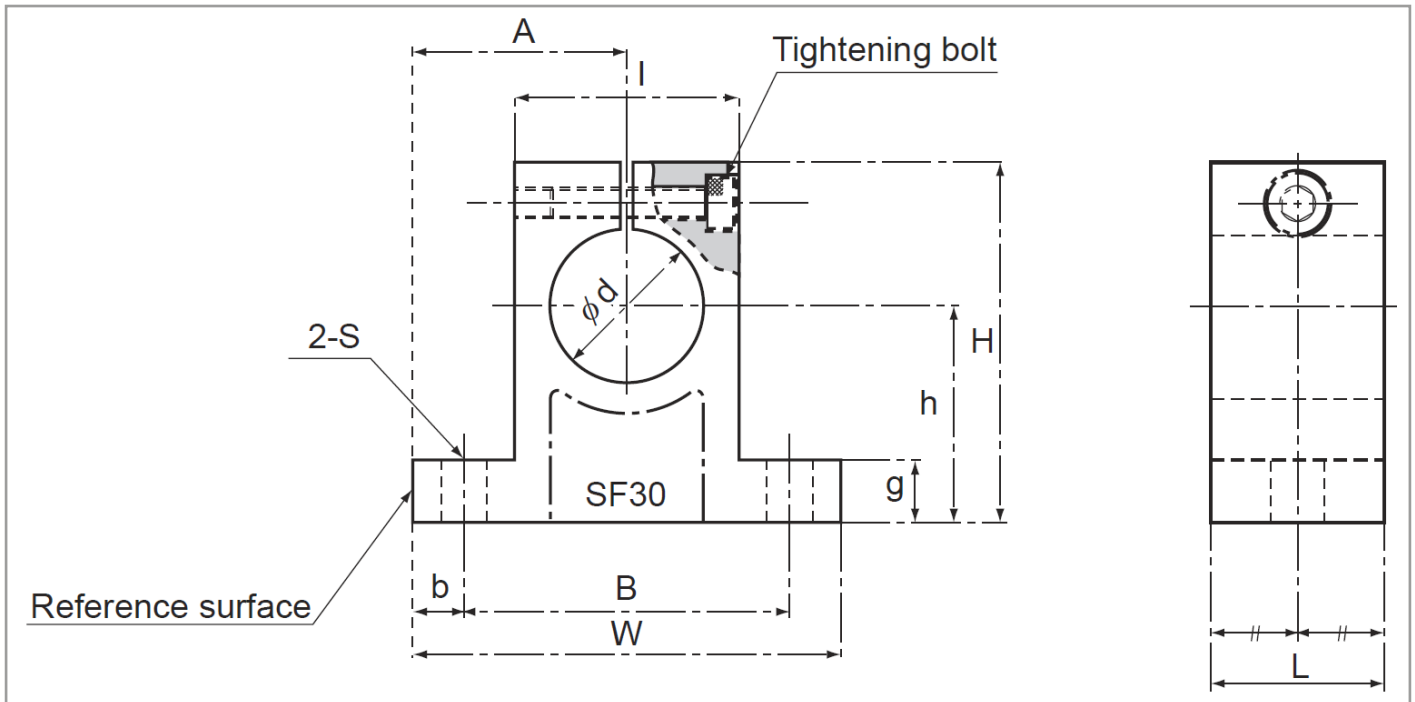

Unit: mm

Model No.	Main dimensions													Mass g
	H	W	L	B	S	Mounting bolt model No.	h ±0.02	A ±0.05	b	g	I	Shaft diameter d	Tightening bolt model No.	
SF10	32.8	42	14	32	5.5	M5	20	21	5	6	18	10	M4	24
SF 12	37.5	42	14	32	5.5	M5	23	21	5	6	20	12	M4	30
SF 13	37.5	42	14	32	5.5	M5	23	21	5	6	20	13	M4	30
SF 16	44	48	16	38	5.5	M5	27	24	5	8	25	16	M4	40
SF 20	51	60	20	45	6.6	M6	31	30	7.5	10	30	20	M5	70
SF 25	60	70	24	56	6.6	M6	35	35	7	12	38	25	M6	130
SF 30	70	84	28	64	9	M8	42	42	10	12	44	30	M6	180
SF 35	83	98	32	74	11	M10	50	49	12	15	50	35	M8	270
SF 40	96	114	36	90	11	M10	60	57	12	15	60	40	M8	420

VKE manufactures high quality, dedicated LM shafts for linear bushings

1. Major materials

- SUJ2 high-carbon chromium bearing steel
- 5SP standard material
- SUS440C equivalent Hardness 58 to 64 HRC
- Hardened layer depth 0.8 to 2.5 mm (varies with shaft diameter)
- Surface roughness Ra0.20 to Ra0.40
- Straightness of the SF shaft 50 µm/300 mm or less

2. Precision-grade SF shafts with shaft diameter tolerance of g5 or h5 are also manufactured as standard.

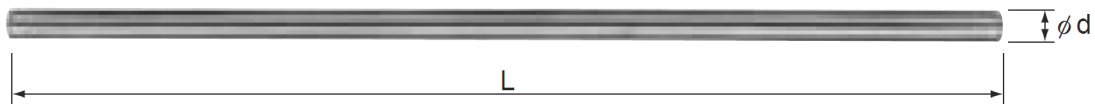

Unit: mm

Model No.	Shaft diameter		Manufactured length L	
	d	Tolerance g6 µm	Min length	Max length
SF 3	3	-2 -8	20	400
SF 4	4	-4 -12	20	400
SF 5	5		20	500
SF 6	6	-5 -14	20	1500
SF 8	8		20	1500
SF 10	10	-6 -17	30	1500
SF 12	12		30	1500
SF 13	13	-7 -20	30	1500
SF 16	16		40	3000
SF 20	20	-9 -25	40	3000
SF 25	25		50	3000
SF 30	30	-10 -29	60	3000
SF 35	35		70	3000
SF 38	38	-12 -34	100	3000
SF 40	40		100	3000
SF 50	50	-10 -29	100	3000
SF 60	60		200	3000
SF 80	80	-12 -34	200	3000
SF 100	100		200	3000

Официальный импортер VKE Group - Базовая техника

+7(800) 511-57-54



[sales@baztehshop.ru](mailto:sales@baztehshop.ru)